

BLANKETROL® III

Operation and Technical Manual Model 233 Hyper-Hypothermia System



GENTHERM

Gentherm Medical, LLC • 12011 Mosteller Road • Cincinnati, Ohio 45241, U.S.A.

www.gentherm.com

BLANKETROL® is a registered trademark of Gentherm Medical, LLC, Cincinnati, Ohio USA.

©Copyright 2026, Gentherm Medical, LLC All rights reserved.

Manual 56201 Rev. AS

BLANKETROL III Symbol Definitions



Read Operation Instructions and Manual Before Operating



Temperature Set



Gradient 10° C



Gradient Variable



INCREMENT (Increase Temperature)



DECREMENT (Decrease Temperature)



Automatic Control



Manual Control

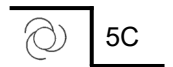

Smart Mode



Monitor Only



Test Indicators



Water Temperature



Patient Temperature



Silence Alarm



Water Flow Indicator



Fill to Strainer

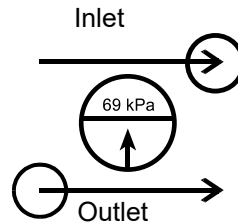

Low Water Level



Risk of Explosion: Do not use in the Presence of Flammable Anesthetics



Disconnect Power Before Servicing



Danger; Risk of Electric Shock

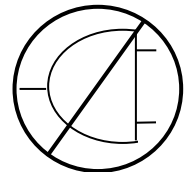

Power Failure



ESD Susceptibility



Separate Disposal for Electrical / Electronic Equipment



Type BF Equipment



Medical Device



Power Cord Holder



OFF / ON Switch



OFF / ON Switch



Equipotential Symbol



AC Voltage

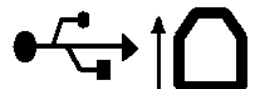

USB Port: Insert Port in This Direction

BLANKETROL® III OPERATION AND TECHNICAL MANUAL

Gentherm Medical, LLC, reserves the right to make equipment changes and improvements, which may not be reflected in this manual

WARNING

- A physician's order is required for setting blanket temperature and use of equipment. At least every 20 minutes, or as directed by physician, check patient's temperature and skin integrity of areas in contact with blanket; also, check the BLANKETROL III's water temperature. Pediatric patients, temperature-sensitive patients with vascular disease, surgical patients, diabetics and patients with Raynaud's Disease are at a greater risk for developing tissue injuries, and this should be considered when selecting the temperature, duration of therapy and frequency of skin checks. **Notify the physician promptly of any change in patient status in order to avoid serious injury or death.**
- The method of temperature control provided by all hyper-hypothermia units presents the danger of heating or cooling body tissues, particularly the skin, to a point where they are injured, i.e., burns or frostbite, respectively. The clinician is responsible for determining the appropriateness of the temperature limits in dependency to time. **Exceeding 40°C water temperature for extended periods can cause tissue damage and burns. Clinical judgment should be used to determine the safe maximum contact periods based on patient age, clinical condition, and current medications. Depending on the extent and severity of a burn, very serious and even fatal complications may arise.**
- Do not use the BLANKETROL III System distal to arterial cross clamping. **Thermal injury may result.**
- **Thermal injury may occur** if heating/cooling therapy is applied to ischemic limbs.
- The warming of transdermal medications (patches) can increase drug delivery, **resulting in possible injury to the patient.**
- Prevent excessive and/or prolonged tissue pressure and shearing forces, especially over bony prominences. **Failure to do so may result in tissue injury.**
- Do not place additional heat sources between the patient and blanket. **Tissue damage may result.**
- Means to maintain contact between the patient and the blanket during therapy may be required and should not block the fluid pathways of the blanket or connecting hose. **Failure to do so may result in inadequate treatment.**
- Prep solutions have been reported to injure the skin when allowed to remain between patients and a water-circulating heating blanket during prolonged procedures. Use of materials of good thermal conductivity, such as water, gel, and similar substances, with the BLANKETROL III not switched ON may decrease the temperature of the patient. **The area between the patient and the blanket should be kept dry to avoid injury to patient.**
- Proper sanitation procedures must be practiced, and hygienic safety must be maintained, to prevent contamination. **Contamination can affect patient's health, i.e. skin irritation/rash may result.**
- Use only YSI 400 Series, or equivalent, probes on GENTHERM equipment (refer to Table (6-8)). **Failure to do this will cause incorrect temperature readings and may result in inadequate/inappropriate treatment.**
- Due to static electricity, a 400 Series Probe may not be connected to the BLANKETROL III unit without first discharging one's body to the frame of the BLANKETROL III unit or another grounded object. **Failure to do so may result in damage from electrostatic discharge (ESD).** All staff that may touch the 400 Series Probe must be familiar with this warning and basic static electricity or electrostatic discharge (ESD) training.

WARNING

<ul style="list-style-type: none"> Basic static electricity or ESD training should include an introduction to the physics of electrostatic charge, the voltage levels that can occur in normal practice and the damage that can be done to electronic components if equipment is touched by an operator who is electrostatically charged. Further, an explanation should be given of methods to prevent build-up of electrostatic charge, and how and why to discharge one's body to the BLANKETROL III unit or another grounded object. Failure to do so may result in damage from electrostatic discharge (ESD).
<ul style="list-style-type: none"> Do not use the BLANKETROL III system in the presence of flammable anesthetics. Risk of explosion can result.
<ul style="list-style-type: none"> Remove the BLANKETROL III from service if the outer casing or membrane control panel is cracked or internal components are exposed. Contact with internal components could result in electric shock or thermal injury to the patient or operator and exposure to sharp edges.
<ul style="list-style-type: none"> Keep grill and condenser clean and free of debris and obstruction. Blockage of the grill and condenser could result in the unit overheating which could render the unit unable to provide adequate therapy and excessive surface temperatures could cause injury of patient or operator. Keep unit, specifically the grill away from curtains or other obstructions.
<ul style="list-style-type: none"> The USB connection on the BLANKETROL III unit is intended for data transfer to a computer. Any other uses/connections may result in damage to the BLANKETROL III unit.
<ul style="list-style-type: none"> Working with electronic boards, plugs, and cables requires delicate handling. Proper electrostatic discharge (ESD) procedures should be followed during replacement of any electronic board. Failure to do so may result in damage to the board.
<ul style="list-style-type: none"> If unit requires repair, do not attempt to fix unit on your own. Only qualified personnel should perform repairs. Damage to the unit or malfunction may otherwise result.
<ul style="list-style-type: none"> Use of accessories other than those specified in Table 6-8 may result in increased electromagnetic emissions or decreased immunity to electromagnetic emissions of the BLANKETROL III unit. This could affect the BLANKETROL III's compatibility with other electrical equipment. Electromagnetic compatibility refers to electronic devices unintentionally affecting the operation of each other by emitting electromagnetic energy.
<ul style="list-style-type: none"> Power interruption will cause the BLANKETROL III to revert to CHECK SET POINT resulting in no therapy to the patient. Follow instructions for desired mode to resume operation. Failure to resume therapy could result in serious injury or death.
<ul style="list-style-type: none"> Do not by-pass ground lug (230V System). Electrical Hazards may result.
<ul style="list-style-type: none"> To avoid the risk of electric shock, this equipment must only be connected to a supply mains with protective earth. Risk of electrical shock may occur.
<ul style="list-style-type: none"> Blanket punctures can result in an increased risk of infection or electrical shock. Inspect all blankets for mechanical damage before use. Do not use in proximity to sharp objects.
<ul style="list-style-type: none"> Any time water is found leaking into or around the unit, connecting hose, and/or blanket, turn the unit off, disconnect the power cord from its power source, and correct the problem before proceeding. Proper maintenance procedures should be followed including, but not limited to, the preventative maintenance described in this manual. Leaky blankets or hoses should never be used. Water leaks could present a slip hazard and risk of infection and could lead to electric shock.
<ul style="list-style-type: none"> Exercise extreme caution if the BLANKETROL III System is used on patients with cardiac issues, for example, patients with pacemakers, or when a probe is inserted in or attached to the patient. Failure to properly monitor patient may result in serious injury or death.
<ul style="list-style-type: none"> Due to electromagnetic compatibility, the BLANKETROL III unit should not be used adjacent to or stacked with other equipment. Potential electromagnetic interference may result. Other equipment includes ventilators, patient monitors, anesthesia delivery equipment, etc. Electromagnetic interference refers to electronic devices unintentionally affecting the operation of each other by emitting electromagnetic energy. Unit complies with IEC 60601-1-2.

WARNING

- If the BLANKETROL III unit or the other equipment is not operating normally, remove the device from service and have a biomedical or service technician observe the device in operation. Refer to Section 7 for recommended separation distances between other equipment and the BLANKETROL III. **Failure to do so may result in damage to the BLANKETROL III system and patient injury.**
- Always **unplug the unit** before accessing internal components during service. **Failure to unplug the unit could result in electric shock.**
- The repair, calibration, and servicing of the BLANKETROL III should be performed by qualified Medical Equipment Service Technicians, Certified Biomedical Electronics Technicians, or Certified Clinical Engineers familiar with good repair practices for servicing medical devices, and in accordance with instructions contained in this manual. **Improper repair can result in damage to the BLANKETROL III system and patient injury.**
- No modification of this equipment is allowed without prior, written authorization from GENTHERM. **Failure to do so may result in damage to the BLANKETROL III system and patient injury.**
- **Before** returning the BLANKETROL III to patient use **after** repairs, the FIRST TIME SET-UP/SYSTEM TEST ROUTINE in Section 2 must **always** be performed. **Improper repair and inadequate maintenance can result in damage to the BLANKETROL III system and patient injury.**

CAUTION

<ul style="list-style-type: none"> Federal law restricts this device to sale by or on the order of a physician.
<ul style="list-style-type: none"> Use Sterile water or water that has been passed through a filter less than or equal to 0.22 microns only. Do Not Use distilled water. Do Not Use De-ionized water. De-ionized water may cause corrosion to plumbing system components. Do Not Use Tap Water. Minerals and deposits can clog plumbing system components.
<ul style="list-style-type: none"> Do not use alcohol. Alcohol may cause blanket and unit deterioration.
<ul style="list-style-type: none"> Use only hospital grade plug or electric shock may result.
<ul style="list-style-type: none"> Do not overfill. Overfilling may result in overflow when the water in the blanket drains back into the system when the system is turned off.
<ul style="list-style-type: none"> Always drain the BLANKETROL III to a sanitary drain because bio-contaminants may be present in the unit's water supply.
<ul style="list-style-type: none"> Handling or use of the patient probe may result in damage from electrostatic discharge (ESD) if proper precautions are not taken.
<ul style="list-style-type: none"> All wire-lead, patient-connected transducer assemblies are subject to reading error, local heating, and possible damage from high intensity sources of RF energy. Inadequately grounded electrosurgical equipment represents one such source, since capacitively coupled currents may seek alternate paths to ground through probe cables and associated instruments. Patient burns may result. If possible, remove the probe from patient contact before activating an electrosurgical unit.
<ul style="list-style-type: none"> Do not immerse probes or connecting cables in liquid. Failure to do so may result in damage to the probes.
<ul style="list-style-type: none"> If the unit was shipped on its side, permit the unit to rest in an upright position for twelve (12) hours before operating due to refrigeration oil displacement.
<ul style="list-style-type: none"> For safe handling and use of chemicals follow manufacturer guidelines.
<ul style="list-style-type: none"> Do not make any connection to the USB port terminal while the device is also connected to a patient. Do not touch this connector and the patient at the same time. Patient injury may result.
<ul style="list-style-type: none"> Users should not use cleaning or decontamination methods different from those recommended by GENTHERM without first checking with GENTHERM that the proposed methods will not damage the equipment.
<ul style="list-style-type: none"> Working with electronic boards, plugs, and cables requires delicate handling. Proper electrostatic discharge (ESD) procedures should be followed during replacement of any electronic board. Failure to do so may result in damage to the board.
<ul style="list-style-type: none"> If device is set to operate in any Automatic mode, the device will shut down and activate the CHECK PROBE alarm if the patient temperature falls below 30.0°C (86°F). Patient temperature must rise above 30.0°C (86°F) before restarting the device in Automatic mode. The device can be operated in Manual Control mode in order to warm the patient above 30.0°C (86°F). Potential for interruption of therapy.
<ul style="list-style-type: none"> Unapproved blankets or hoses should never be used.
<ul style="list-style-type: none"> Do not use GRADIENT VARIABLE MODE OR GRADIENT 10C MODE without SMART MODE. Unintended therapy could occur.

Table of Contents

TECHNICAL HELP 10

 BEFORE YOU CALL FOR SERVICE..... 10

 IN-WARRANTY REPAIR AND PARTS 10

RECEIVING INSPECTION 10

IMPORTANT SAFETY INFORMATION 10

SECTION 1. INTRODUCTION..... 11

 1-0. GENERAL SAFETY PRECAUTIONS..... 11

 1-1. GENERAL DESCRIPTION OF THIS MANUAL 11

 1-2. GENERAL DESCRIPTION OF THE BLANKETROL III SYSTEM 12

 1-3. PHYSICAL DESCRIPTION OF THE BLANKETROL III UNIT 12

 1-3.1. External Features - Front View 12

 1-3.2. External Features – Right Side View 14

 1-3.3. External Features – Rear View 16

 1-3.4. Description of the BLANKETROL III Membrane Control Panel 17

 1-4. REQUIRED ACCESSORIES 19

 1-5. FUNCTIONAL DESCRIPTION OF THE BLANKETROL III SYSTEM 19

 1-5.1. Theory of Operation..... 19

 1-5.2. Heating System 22

 1-5.3. Cooling System 22

 1-5.4. Circulating System 22

 1-5.5. Temperature Safety Control System..... 23

 1-5.6. USB Port Operation..... 23

SECTION 2. GENERAL PREPARATION OF THE BLANKETROL III SYSTEM..... 24

 2-1. INTRODUCTION 24

 2-2. UNPACKING THE SHIPMENT..... 24

 2-3. FIRST TIME SET-UP/SYSTEM TEST ROUTINE 24

 2-3.1. Inspecting and Arranging the Equipment 24

 2-3.2. Completing a System Test Routine..... 26

 2-4. UNIT AND PATIENT RELATED PRECAUTIONS 31

 2-5. PATIENT PREPARATION AND BEDSIDE CARE 32

SECTION 3. OPERATING THE BLANKETROL III SYSTEM..... 36

 3-1. INTRODUCTION 36

 3-2. ARRANGING THE SYSTEM COMPONENTS..... 36

 3-3. OPERATING THE BLANKETROL III SYSTEM IN *AUTO CONTROL MODE* 39

 3-4. OPERATING THE BLANKETROL III SYSTEM IN *MANUAL CONTROL MODE* 41

 3-5. OPERATING THE BLANKETROL III SYSTEM IN *MANUAL CONTROL MODE* WITH THE
 ADDITION OF THE PATIENT PROBE..... 43

 3-6. OPERATING THE BLANKETROL III UNIT IN *GRADIENT 10C SMART MODE* 44

 3-7. OPERATING THE BLANKETROL III SYSTEM IN *GRADIENT VARIABLE SMART MODE* 46

 3-8. OPERATING THE BLANKETROL III SYSTEM IN *MONITOR ONLY MODE* 49

 3-9. CONCLUDING HYPER-HYPOTHERMIA TREATMENT 50

 3-10. STATUS DISPLAY MESSAGES 50

SECTION 4. GENERAL MAINTENANCE OF THE BLANKETROL III SYSTEM 56

 4-1. INTRODUCTION 56

 4-1.1. TEST EQUIPMENT REQUIRED 57

 4-2. MAINTENANCE OF THE WATER RESERVOIR..... 59

 4-2.1. Draining the Reservoir 61

 4-2.2. Replenishing the Reservoir 62

 4-3. MAINTENANCE OF THE WATER FILTER 63

 4-4. MAINTENANCE OF THE CONDENSER AND GRILL 63

4-5. MAINTENANCE OF THE BLANKETROL III EXTERIOR – CLEANING INSTRUCTIONS 64

4-6. MAINTENANCE OF THE HYPER-HYPOTHERMIA BLANKETS 64

 4-6.1. *Reusable Blanket*..... 64

 4-6.2. *Disposable, Single-Patient Use Blankets*..... 64

4-7. LOW LIMIT SAFETIES CHECK 65

4-8. HIGH LIMIT SAFETIES CHECK 65

4-9. TEMPERATURE ACCURACY CHECK 66

4-10. DISPOSAL OF THE BLANKETROL II UNIT 66

SECTION 5. FIELD REPAIR/SERVICE OF THE BLANKETROL III UNIT 67

5-1. INTRODUCTION 67

5-2. ACCESS TO THE INTERIOR OF THE BLANKETROL III UNIT 70

 5-2.1. *Removing the Rear Enclosure Panel*..... 70

 5-2.2. *Removing the Top of the Unit* 70

 5-2.3. *Removing the Left Side Enclosure Panel* 70

 5-2.4. *Disconnecting the Cables from the Microprocessor Board*..... 71

 5-2.5. *Extending the Front Storage Drawer*..... 71

 5-2.6. *Repositioning the Front Storage Drawer*..... 72

5-3. REPLACEMENT OF THE HEATER 72

5-4. REPLACEMENT OF THE WATER FILTER ASSEMBLY 72

5-5. REPLACEMENT OF THE PUMP HOUSING 73

5-6. REPLACEMENT OF THE PUMP MOTOR 74

5-7. REPLACEMENT OF THE FLOW SWITCH 76

5-8. REPLACEMENT OF THE WATER TEMPERATURE SENSOR 76

5-9. REPLACEMENT OF THE UPPER AND/OR LOWER WATER MANIFOLDS 77

5-10. REPLACEMENT OF THE COMPRESSOR STARTING CAPACITOR, THE OVERLOAD PROTECTOR, AND/OR THE COMPRESSOR RELAY 78

5-11. REPLACEMENT OF THE THERMAL DISC OVER TEMPERATURE DEVICE 79

5-12. REPLACEMENT OR CLEANING OF THE WATER FLOW INDICATOR ASSEMBLY 79

5-13. REPLACEMENT OF THE I/O POWER SWITCH 80

5-14. REPLACEMENT OF THE WATER LEVEL SENSOR ASSEMBLY 81

5-15. REPLACEMENT OF THE MICROPROCESSOR BOARD AND/OR THE MEMBRANE CONTROL PANEL 81

5-16. REPLACEMENT OF THE BEEPER ASSEMBLY 82

5-17. REPLACEMENT OF THE POWER CORD 82

5-18. LEAKAGE CURRENT 83

 5-18.1. *Arranging the Equipment*..... 83

 5-18.2. *Taking Measurements in Normal Polarity* 83

 5-18.3. *Taking Measurements in Reverse Polarity*..... 84

5-19. REFRIGERANT CHECK 84

5-20. TROUBLESHOOTING GUIDE 85

SECTION 6. PARTS INFORMATION 91

6-1. INTRODUCTION 91

6-2. ORDERING INFORMATION FOR REPLACEMENT PARTS 91

6-3. RECOMMENDED REPLACEMENT PARTS INVENTORY 91

6-4. RETURNING PARTS UNDER WARRANTY 92

6-5. SHIPPING PARTS 92

SECTION 7. SPECIFICATIONS AND CERTIFICATIONS OF THE BLANKETROL III 101

WORLDWIDE ORDER PLACEMENT 105

FIGURES AND TABLES

FIGURE 1-1. BLANKETROL III - FRONT VIEW 13

FIGURE 1-2. BLANKETROL III - RIGHT SIDE 15

FIGURE 1-3. BLANKETROL III - REAR VIEW 16

FIGURE 1-4. A. BLANKETROL III - MEMBRANE CONTROL PANEL (ENGLISH) 18

FIGURE 1-4. B. BLANKETROL III - MEMBRANE CONTROL PANEL (SYMBOLS) 18

FIGURE 4-1. BLANKETROL III MAINTENANCE CHECKLIST 58

FIGURE 5-1. BLANKETROL III - EXPOSED REAR VIEW 69

FIGURE 6-1. PARTS LIST A 93

FIGURE 6-2. BLANKETROL III - INTERNAL EXPLODED - FRONT VIEW 94

FIGURE 6-3. PARTS LIST B 95

FIGURE 6-4. BLANKETROL III - INTERNAL EXPLODED - REAR VIEW 96

FIGURE 6-5. A. BLANKETROL III - ELECTRICAL WIRING DIAGRAM - 115 VOLT 97

FIGURE 6-5. B. BLANKETROL III - ELECTRICAL WIRING DIAGRAM - 230 VOLT 98

FIGURE 6-6. BLANKETROL III - WATER CIRCULATION DIAGRAM 99

FIGURE 6-7. BLANKETROL III - REFRIGERATION FLOW DIAGRAM 99

TABLE 7-1. GUIDANCE AND MANUFACTURER'S DECLARATION - ELECTROMAGNETIC EMISSIONS 103

TABLE 7-2. GUIDANCE AND MANUFACTURER'S DECLARATION - ELECTROMAGNETIC IMMUNITY 103

TABLE 7-3. GUIDANCE AND MANUFACTURER'S DECLARATION - ELECTROMAGNETIC IMMUNITY 104

TABLE 7-4. RECOMMENDED SEPARATION DISTANCES BETWEEN PORTABLE AND MOBILE RF COMMUNICATIONS
EQUIPMENT AND THE BLANKETROL III, MODEL 233 105

TECHNICAL HELP

United States and Canada
Gentherm Medical, LLC
12011 Mosteller Road
Cincinnati, OH 45241
www.gentherm.com

Telephone	1-513-772-8810
(U.S.) Toll Free	1-800-989-7373
(U.S.) 24hr Clinical Support	1-513-460-2038
Fax	1-513-772-9119

BEFORE YOU CALL FOR SERVICE...

To help us better serve you, please have the serial number of your BLANKETROL III unit ready when you call for parts or service. The serial number is located on a specification label attached to the unit's rear panel.

How to read serial numbers:

Example: 121-3-60000

- 12 indicates a manufacturing date of the year 2012
- 1 indicates the quarter (first)
- -3- means BLANKETROL III, Model 233
- 60000 indicates that this is the 60,000th unit of a certain model

IN-WARRANTY REPAIR AND PARTS

All parts on your BLANKETROL III unit are covered by a two-year (2) warranty. Additional third year warranty is available at the time of purchase. To return defective parts or units, first obtain a Returned Materials Authorization (RMA) number from our Medical Technical Service department. All returns should be made using GENTHERM-issued shipping cartons.

RECEIVING INSPECTION

After unpacking the BLANKETROL III System, be sure to inspect the system for concealed damage. Retain all packing material and carefully describe or photograph any damage. Notify the carrier at once and ask for an inspection (in writing). Failure to do this within 15 days may result in loss of claim. Do not return the equipment to Gentherm. Call our Medical Technical Service department for further instructions.

IMPORTANT SAFETY INFORMATION

Refer to this manual for instructions and operator information. Read and understand all WARNINGS / CAUTIONS before using, prescribing, or servicing the BLANKETROL III System.

SECTION 1. INTRODUCTION

1-0. GENERAL SAFETY PRECAUTIONS

To provide the patient maximum safety during the use of the BLANKETROL III System, a thorough knowledge and understanding of the system, and its correct application and operating use are required. Each person who is responsible for use or direction of use of the system, such as physicians, nurses, technicians and operators must read and understand this operating manual and all precautions and warnings prior to use. It is recommended this manual be read at least semi-annually as a refresher for safe operation and application. **For proper knowledge and understanding, in-service is available upon request.**

Maintenance and service activities will sometimes overlap. In general, maintenance refers to any activity that does not require a certified technician. Maintenance may be performed by healthcare personnel or by other trained persons. The following actions are considered maintenance:

1. Inspecting, cleaning, and disinfecting the exterior
2. Adding or replacing water
3. Replacing hoses
4. Cleaning hoses, blankets
5. Draining reservoirs

Service refers to any activity that requires a Medical Equipment Service Technician, Certified Biomedical Electronics Technician, or a Certified Clinical Engineer. The following actions are considered service:

1. Equipment or parts replacement
 2. Repairs
 3. System testing
 4. Cleaning & disinfecting water reservoirs
 5. Replacing hoses (air, water), cords, and other accessories
-

1-1. GENERAL DESCRIPTION OF THIS MANUAL

This manual describes the operation, maintenance, and service of the GENTHERM BLANKETROL III System. Section one describes the physical and functional characteristics of the BLANKETROL III System. Section two describes how to prepare the BLANKETROL III System for general use. Section three describes how to operate the unit in the *MANUAL CONTROL MODE*, *AUTO CONTROL MODE*, *GRADIENT 10C SMART MODE*, *GRADIENT VARIABLE SMART MODE*, and *MONITOR ONLY MODE*. Section four describes the regular maintenance of the BLANKETROL III unit. Section five describes Field Repair and Service of the BLANKETROL III unit and contains a troubleshooting guide. Section six outlines parts information and section seven list specifications of the BLANKETROL III.

This manual is prepared for professional personnel who use BLANKETROL III for patient care as well as technicians and service personnel who are responsible for maintaining the equipment. All personnel who operate or service the unit should be familiar with all parts of this manual. However, Sections one, two, and three are primarily intended for personnel who unpack and setup the unit. Section three is primarily intended for personnel who operate the unit, and Sections three through six are primarily intended for personnel who service and repair the unit. Section (1-3.) describes the external features of the BLANKETROL III and Section (3-10.) describes display messages. These sections should be consulted if questions arise over the terminology used in this manual.

Operating modes are described in Section (1-5.1.) and are highlighted throughout the manual in italics and capital letters. Button names and display messages are shown in all capital letters.

1-2. GENERAL DESCRIPTION OF THE BLANKETROL III SYSTEM

INDICATIONS FOR USE

The BLANKETROL III Hyper-Hypothermia Temperature Management System is used to lower or to raise a patient's temperature and/or maintain a desired patient temperature through conductive heat transfer. The system is composed of a heater, a compressor, a circulating pump and blankets/pads.

BLANKETROL III Model 233

This unit requires no field adjustments or calibrations to maintain the precise board measurement of temperature and temperature limits.

Sterile water or water that has been passed through a filter less than or equal to 0.22 microns is heated or cooled and pumped from the unit to a blanket. The blanket* rests under and/or on top of the patient and is designed so that the water circulates through the blanket and returns to the unit.

If water that is at a lower temperature than the patient's temperature is circulated through the blanket, the desired effect is to reduce the patient's temperature. If water that is at a higher temperature than the patient's temperature is circulated through the blanket, the desired effect is to elevate the patient's temperature.

The BLANKETROL III unit can be set so that it operates based on the temperature of the water in the BLANKETROL III equipment (MANUAL CONTROL MODE) or it can be set so that it operates based upon the patient's temperature (Automatic Modes). The three Automatic modes include:

- 1) *AUTO CONTROL MODE*
- 2) *GRADIENT 10C SMART MODE*
- 3) *GRADIENT VARIABLE SMART MODE*

The BLANKETROL III System can also be used solely to monitor the temperature of the patient (MONITOR ONLY MODE).

The BLANKETROL III is intended for use in ambient temperatures of 15°C – 30°C (59°F – 86°F). The maximum contact surface temperature is 41°C (105.8°F).

* The recommended blanket(s) for use are described in Table 6-8.

1-3. PHYSICAL DESCRIPTION OF THE BLANKETROL III UNIT

See Section (7.) for specifications and certifications of the BLANKETROL III.

1-3.1. External Features - Front View

The external features in Figure (1-1.) of the BLANKETROL III unit are described as follows:

- A. The control panel is composed of pressure sensitive touch switches, nine LED indicators, a liquid crystal display, and two LED displays. An expanded description of the membrane control panel is presented in Section (1-3.4.).
- B. The recessed handle permits the operator to grip the unit when moving it.
- C. The power switch is a bevel rocker switch labeled "I" (on) at the top and "O" (off) at the bottom. The switch illuminates green when the unit is on. A circuit breaker is built into the switch to protect against overload conditions.
- D. The storage drawer tilts out from the top to provide storage space for items such as probes, connecting cables, connecting hoses, the drain hose, and the Operator's Manual.

- E. The grill permits air to be drawn into the unit and pass over the condenser. The air is then discharged through the bottom of the unit. The grill and compressor should be kept clear from blockage and cleaned regularly as described in Section (4-4.).
- F. The protective bumper guard surrounds the lower edge of the unit and protects the unit as well as the walls.
- G. Four swivel casters are specially designed to permit the unit to move easily and to prevent it from tipping. The casters are equipped with locking features to prevent unintended movement during operation.

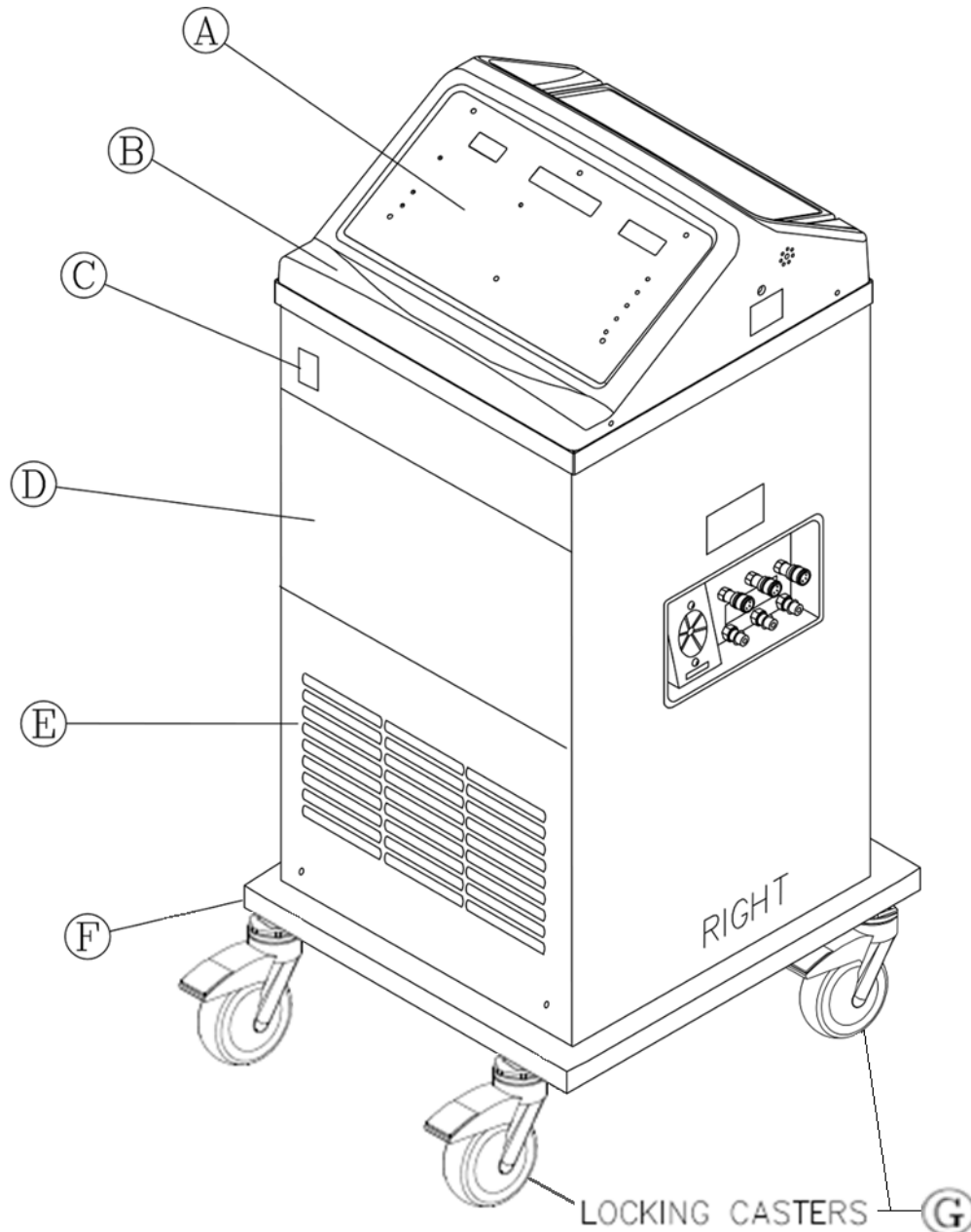

FIGURE 1-1. BLANKETROL III - FRONT VIEW

1-3.2. External Features – Right Side View

The external features in Figure (1-2.) of the BLANKETROL III unit are described as follows:

- A. The water flow indicator is a paddle wheel immersed in the path of the circulating water with a window to the outside. As water is circulated through the system, it passes over the paddle wheel causing it to spin (like a pinwheel). The water flow indicator provides a visual display of the general rate at which the water is circulating. For example, if the unit is circulating water but the connecting hose is pinched, the circulation of the water is restricted. The restriction in water flow decreases the speed of the paddle wheel.

The water flow indicator only spins when a blanket or bypass hose is connected to the unit. It will not spin while the water is being circulated internally to pre-condition the water to the 'preset' water temperature chosen by the operator.

A total obstruction of the water path will cause the paddle wheel to stop completely.

- B. The air vents, on both the right and left side of the unit, provide air circulation for the microprocessor.
- C. The four capped screws on the right and left side of the unit secure the top to the base.
- D. The patient 1/4-inch receptacle is where the 400 Series probe (refer to Table 6-8 for a list of temperature probes) is connected to the unit. Only one patient probe can be connected at a time.
- E. Three female, quick-disconnect return fittings on the top row are designed for water to flow in when the male coupling of the connecting hose is attached.
- F. The three male quick-disconnect outlet fittings on the bottom row are designed for water to flow out when the female coupling of the connecting hose is attached.
- G. The power cord with a hospital-grade plug should only be plugged into a properly grounded hospital grade receptacle. Electrical Specifications are described in Section (7.).
- H. The isolation label indicates that the BLANKETROL III and the blanket (applied part) are BF rated as a system. Contact with other parts (i.e. the quick-disconnect fittings) at the same time as contacting the patient will negate the type of BF rating.

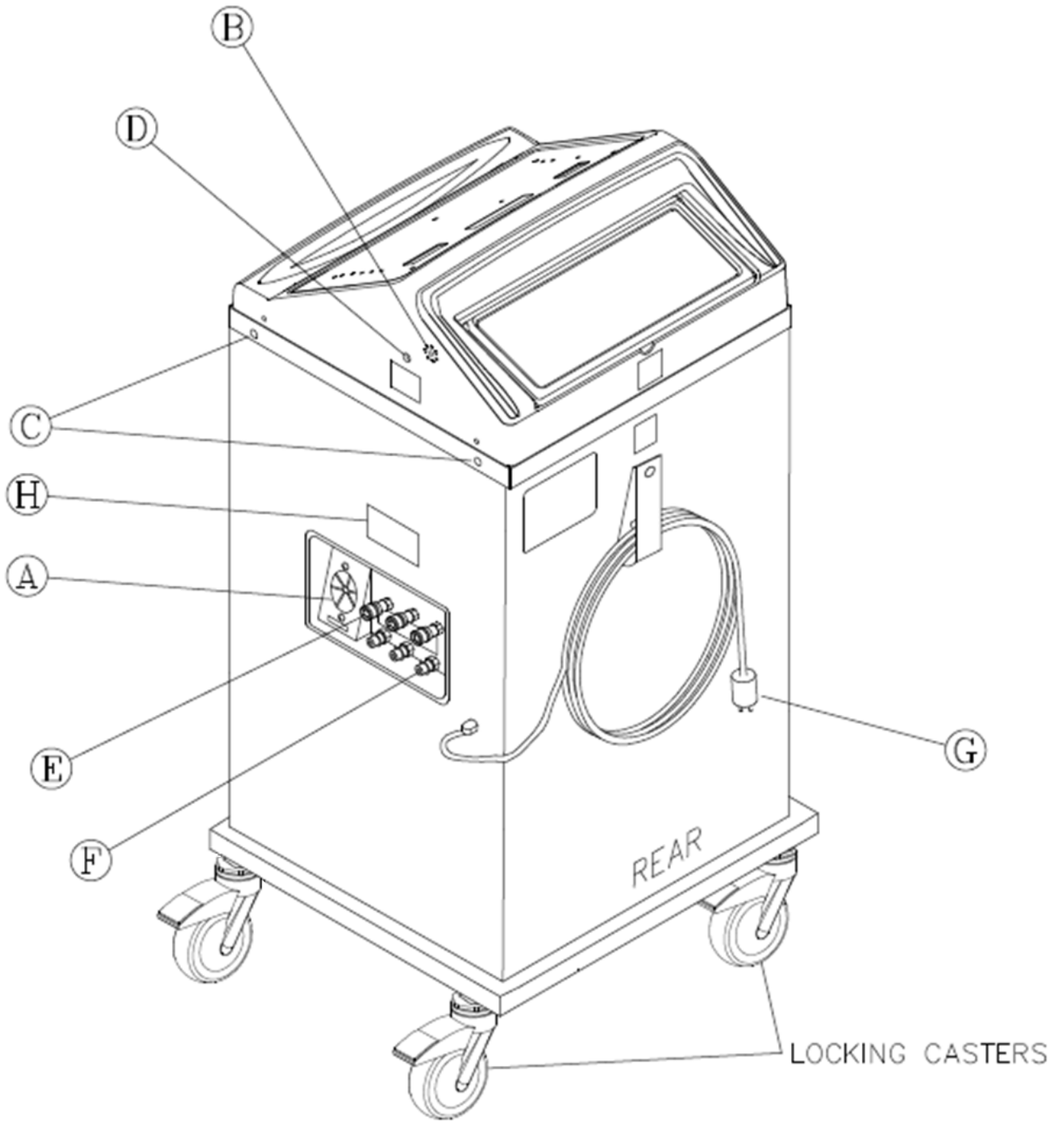

FIGURE 1-2. BLANKETROL III - RIGHT SIDE

1-3.3. External Features – Rear View

The external features in Figure (1-3.) of the BLANKETROL III unit are described as follows:

- A. The specification label outlines the BLANKETROL III unit's electrical requirements and displays the serial and model numbers of the unit.
- B. The air vents, on both the right and left side of the unit, provide air circulation for the microprocessor.
- C. The nylon strap is used to secure and store the coiled power cord when not in use.
- D. The rear enclosure panel secured with four screws provides access to the interior. The panel is removed to perform maintenance, repair, or replacement of components.
- E. The water fill opening is where the operator pours sterile water or water that has been passed through a filter less than or equal to 0.22 microns into the unit to fill the reservoir.
- F. The operating instructions are printed directly on the back lid of the unit. This allows the operator to clearly see the directions and efficiently use the unit.
- G. The USB port for data reporting functions.

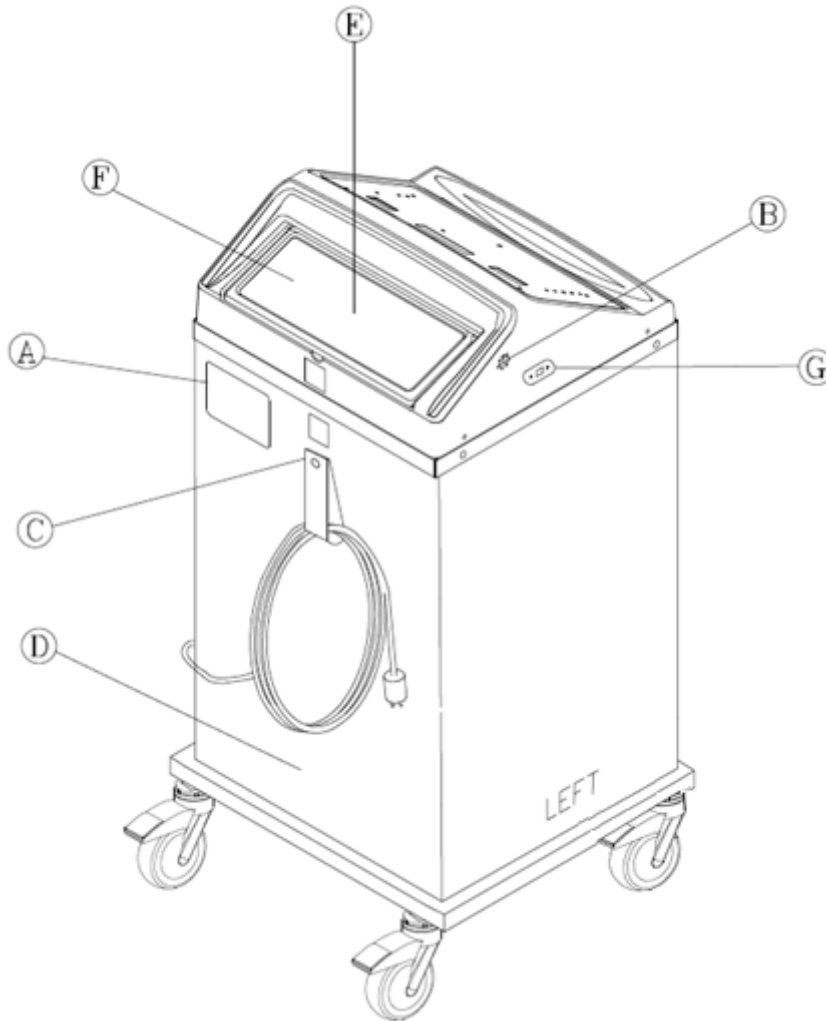

FIGURE 1-3. BLANKETROL III - REAR VIEW

1-3.4. Description of the BLANKETROL III Membrane Control Panel

The membrane control panel as shown in Figure (1-4. A.) for English and (1-4.B.) for Symbols is composed of pressure sensitive touch switches and LED displays. The membrane control panel is divided into the following sections:

- A. The green LED display labeled WATER shows the water temperature in the BLANKETROL III equipment.
- B. The MANUAL CONTROL button is used to activate the MANUAL CONTROL MODE. This mode's operation is based on the water temperature within the BLANKETROL III equipment relative to the desired Set Point temperature.
- C. The green LCD display reports the status of the unit, displays the Set Point, and/or indicates changes the operator should make. It is referred to as the Status Display. The possible Status Displays are listed in Section (3-10.).
- D. The TEMP SET button and the Up and Down arrow buttons are used to adjust the Set Point as shown on the LCD display.
- E. The green LED display, labeled PATIENT, shows the patient's temperature reading.
- F. The AUTO CONTROL button is used to activate the AUTO CONTROL MODE. In this mode, the operation is based on the patient's temperature relative to the desired Set Point temperature.
- G. The GRADIENT 10C button is used to activate the GRADIENT 10C MODE. In this mode, the operation is based on the patient's temperature relative to the Set Point temperature.
- H. The GRADIENT VARIABLE button is used to activate the unit GRADIENT VARIABLE MODE. In this mode, the operation is based on the patient's temperature relative to the desired Set Point temperature.
- I. The SMART button is used to activate the SMART function in the appropriate modes.
- J. The MONITOR ONLY button is used to monitor the patient's temperature without heating, cooling or circulating the water.
- K. The two switches labeled TEST INDICATORS and SILENCE ALARM are used to confirm that all the indicators on the membrane control panel are working and to silence the alarm in certain conditions.
- L. The POWER FAILURE symbol flashes the red LED to the left of the symbol and sounds an audible alarm when the unit loses power or when power has been interrupted, restored, and the unit does not resume previous operation.
- M. The LOW WATER symbol indicates the unit is low on water. The unit flashes the red LED to the left of the symbol, sounds an audible alarm, and displays "LOW WATER" in the Status Display. Refer to Section (3-10-D. Low Water).
- N. The C/F Button allows the operator to select the measurement scale, Celsius or Fahrenheit, by which the unit functions. This feature is only available on units with an English membrane.

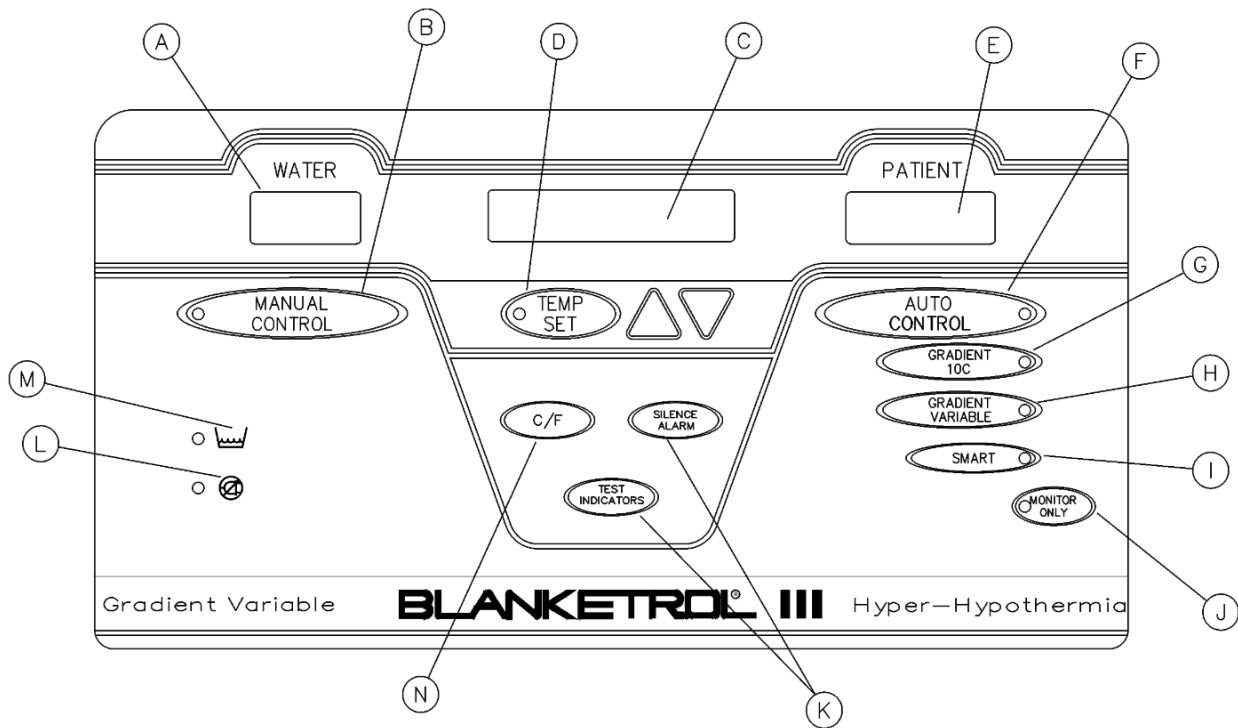

FIGURE 1-4. A. BLANKETROL III - MEMBRANE CONTROL PANEL (English)

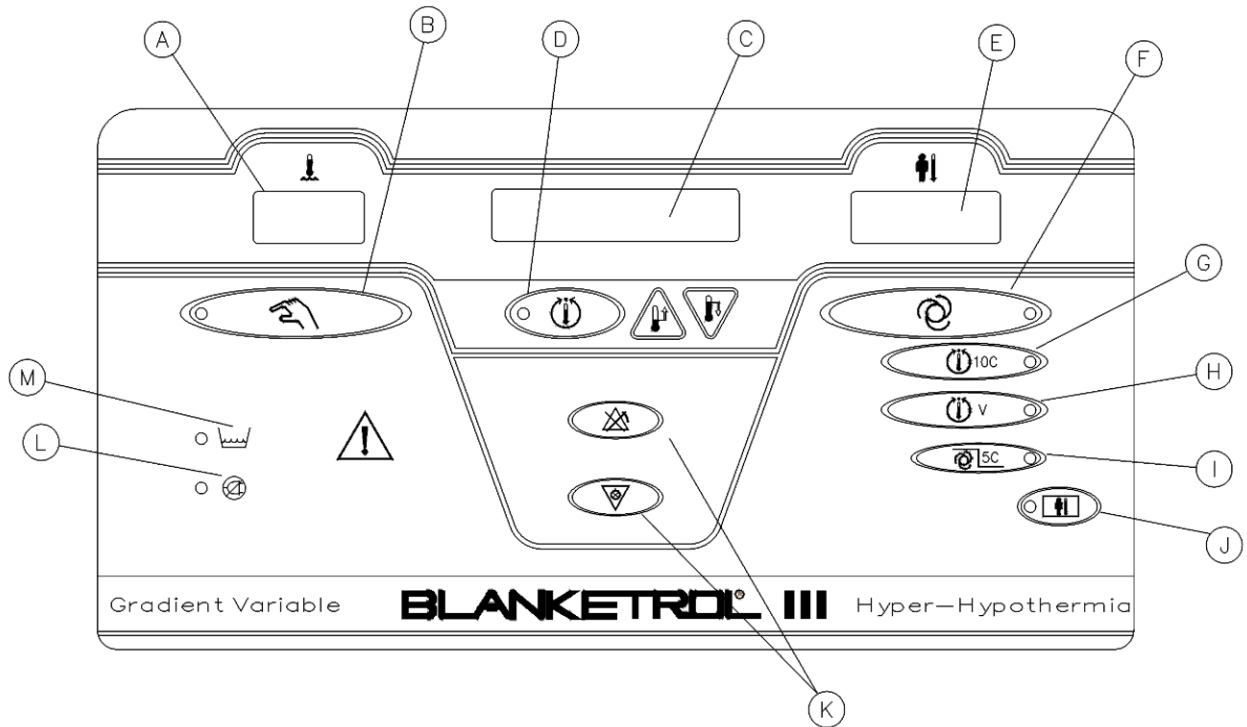

FIGURE 1-4. B. BLANKETROL III - MEMBRANE CONTROL PANEL (Symbols)

1-4. REQUIRED ACCESSORIES

Operation of the BLANKETROL III System requires the use of the blanket(s) designed to circulate warm or cool sterile water or water that has been passed through a filter less than or equal to 0.22 microns, a connecting hose with quick-disconnect male and female fittings and, if any of the automatic modes are to be utilized, a 400 Series thermistor probe. BLANKETROL III System Equipment and accessories are listed in Table (6-8.).

1-5. FUNCTIONAL DESCRIPTION OF THE BLANKETROL III SYSTEM

1-5.1. Theory of Operation

The Blanketrol III unit can be set so that it operates based on the water temperature (**MANUAL CONTROL**), or it can be set to operate based on the patient's temperature (**AUTOMATIC CONTROL**) using servo control. The three Automatic Modes include:

1. **AUTO CONTROL MODE**
2. **GRADIENT 10C SMART MODE**
3. **GRADIENT VARIABLE SMART MODE**

In **MANUAL MODE** the operator selects the circulating water temperature. The unit heats or cools the water to reach the selected temperature. The operator can change the Set Temperature (in this case the water temperature). This mode does not require a patient temperature probe. The patient temperature probe can be attached and used for close monitoring of the patient's temperature; however, it **will not** control or change the water temperature.

Note: The lowest water temperature is 4°C
The highest water temperature is 42°C

Patient temperature and skin integrity should be closely monitored. Exceeding 40°C for extended periods can cause tissue damage and burns. Clinical judgment should be used to determine the safe maximum contact periods based on patient age, clinical condition and current medications.

MANUAL MODE is recommended for:

- Pre-conditioning water to achieve desired water temperature before start of therapy
- Fever control in patients unable to have continuous core temperature monitoring
- Perioperative normothermia or warming of patients that don't require continuous core temperature monitoring.

Based on current recommendations, **MANUAL MODE** should be avoided for Targeted Temperature Management (TTM) and servo control (an Automatic Mode) should be used.

In **AUTO CONTROL MODE** the operator selects the desired **Patient Set Temperature** (based on physician's orders and/or hospital policy). For this function to operate, the patient must have a compatible 400 series temperature probe inserted for core temperature monitoring. The 400 series cable connects the probe to the Blanketrol III. The device operates by measuring the patient's temperature and comparing it to the selected Patient Set Temperature. Based on whether the patient's temperature is below or above the Set Temperature, the water temperature will adjust (heat or cool) to achieve the Patient Set Temperature— this is called servo control. The operator does **NOT** need to adjust the water temperature in this mode. When the patient's core temperature reaches the selected Patient Set Temperature, the device will cycle on and off to maintain this Patient Set Temperature. In **AUTO CONTROL MODE** when the device is cooling, the water may decrease down to 4°C if needed. Conversely, when the device is warming, the water may increase to 42°C if needed. This allows for a fast-aggressive change in the patient's temperature.

Note: The lowest water temperature is 4°C
The highest water temperature is 42°C

Patient temperature and skin integrity should be closely monitored. Exceeding 40°C for extended periods can cause tissue damage and burns. Clinical judgment should be used to determine the safe maximum contact periods based on patient age, clinical condition and current medications.

AUTO CONTROL MODE is recommended for fast, aggressive temperature change for:

- Patients that can be treated for shivering
- Larger patients with denser body mass
- Patients going through withdrawal or that have increased metabolism
- Maintaining perioperative normothermia
- Targeted Temperature Management (TTM) (Current guidelines recommend servo control (Automatic Modes) for all TTM procedures)

SMART MODE should always be used with the GRADIENT MODES. It is a backup mode that can adjust the restrictions of the GRADIENT MODES when patients are warming or cooling in the wrong direction from intended therapy/Patient Set Temperature. **SMART MODE** inhibits water temperature from following the patient temperature to maintain the GRADIENT restriction when it in the wrong direction from intended therapy. SMART mode analyzes the Patient Set Temperature and the actual patient temperature every 30 minutes. If the patient is not at the selected Set Temperature, the software will open the GRADIENT offset up by 5, allowing the water temperature to vary an additional 5°C from the selected GRADIENT offset setting. This will occur every 30 minutes until the patient reaches the Set Temperature. When the patient achieves Set Temperature, the device will revert back to the original GRADIENT MODE setting and the water temperature will gradually change to reflect the original offset.

The Blanketrol III will not alarm or indicate when the patient's temperature is outside of the selected Patient Set Temperature. It is recommended to use an additional temperature monitoring system to set alarm parameters to alert the operator if the patient temperature falls outside of the acceptable range.

CAUTION: Do not use GRADIENT VARIABLE MODE or GRADIENT VARIABLE 10C MODE without SMART MODE. Unintended therapy could occur.

GRADIENT 10C SMART MODE is servo controlled just like the AUTO CONTROL MODE and operates similarly. The device monitors the patient's temperature and adjusts the water temperature to achieve/maintain the desired Patient Set Temperature. The difference in this mode is that the water temperature will only vary 10°C from the patient's actual measured temperature. These restrictions allow the device to gradually adjust the patient's temperature to the selected Patient Set Temperature and/or maintain tighter control of the patient's temperature to limit "overshoot" and temperature variations in larger patient. When the patient's core temperature reaches the selected Patient Set Temperature, the device will cycle on and off to maintain water temperature within 10°C of Patient Set Temperature.

Reminder: Patient temperature variations in surface cooling are normal and expected in the 0.5°C range. No variance at all could point to low metabolic activity.

Note: The lowest water temperature is 4°C
The highest water temperature is 42°C

Patient temperature and skin integrity should be closely monitored. Exceeding 40°C for extended periods can cause tissue damage and burns. Clinical judgment should be used to determine the safe maximum contact periods based on patient age, clinical condition and current medications.

GRADIENT 10C SMART MODE is recommended for gradual or controlled temperature change for:

- Neonates and small patients

- Patients who are overshooting their Set Temperature
- Patients with low metabolism or who are very sedated

GRADIENT VARIABLE SMART MODE is servo controlled just like AUTO CONTROL MODE and operates similarly to GRADIENT10C SMART MODE. The device monitors the patient's temperature and adjusts the water temperature to achieve/maintain the selected Patient Set Temperature. The difference in this mode is that the operator chooses the Variable offset (between 0°C and 33°C) between the patient's temperature and water temperature. **It is not recommended to use a setting of "0". This setting will only allow the water to track the actual patient temperature and therapy may not be adequately delivered to the patient.** The smaller **GRADIENT VARIABLE SMART MODE** settings of 1-4 may not sufficiently heat or cool the patient due to differences/fluctuations between the patient core temperature and skin surface temperature. These restrictions allow the device to gradually adjust the patient's temperature to the selected Patient Set Temperature and/or maintain tighter control of the patient's temperature to limit "overshoot" and temperature variations in larger patient. When the patient's core temperature reaches the selected Patient Set Temperature, the device will cycle on and off to maintain water temperature within a certain range (based on the selected offset VARIABLE) of Patient Set Temperature.

Reminder: Patient temperature variations in surface cooling are normal and expected in the 0.5°C range. No variance at all could point to low metabolic activity.

Note: The lowest water temperature is 4°C
The highest water temperature is 42°C

Patient temperature and skin integrity should be closely monitored. Exceeding 40°C for extended periods can cause tissue damage and burns. Clinical judgment should be used to determine the safe maximum contact periods based on patient age, clinical condition and current medications.

GRADIENT VARIABLE SMART MODE is recommended for gradual or controlled temperature change for:

- Neonates and small patients
- Patients who are overshooting their Set Temperature
- Patients with low metabolism or who are very sedated

The **TEMP SET** button is used to change all therapies and to pause the device by returning the circulating water back to the device from the blanket(s)/pad(s). The device may be paused to add more water, change out blankets or hoses, obtain radiology tests and/or stop therapy. To resume function of the device, the operator will push the **MANUAL** button, the **AUTO CONTROL** button, or the **10C GRADIENT** buttons.

If GRADIENT VARIABLE SMART MODE is being used and the caregiver needs to pause the therapy, press the **GRADIENT VARIABLE** button instead of the **TEMP SET** button. This will pause the therapy and return the circulating water back to the device from the blanket(s)/pad(s). When ready to re-start the device, press the **GRADIENT VARIABLE** button again and the original setting will remain. **However, if the GRADIENT VARIABLE button is being used and is subsequently paused by pushing the TEMP SET button, the VARIABLE offset will be cleared and reset back to 0.** To reprogram the **GRADIENT VARIABLE** offset, push the **GRADIENT VARIABLE** button to restart function.

1-5.2. Heating System

The BLANKETROL III heating system consists of an immersion heater, water temperature control, and three high temperature safety devices. Temperature ranges are described in Section (1-5.5.). The immersion heater is located in the circulating reservoir. The water circulating in the reservoir flows around the immersion heater and is warmed.

The heating system is operational whenever the control system calls for an increase in the temperature of the water in the BLANKETROL III equipment. It is important to note that the rate of change in the temperature of the water in the BLANKETROL III equipment is not directly proportional to the rate of change in the patient's temperature.

1-5.3. Cooling System

The BLANKETROL III cooling system is composed of a compressor, condenser, condenser fan, an evaporator coil, water temperature control, solenoid valve, hot gas by-pass valve, and two low temperature safety devices. Temperature ranges are described in Section (1-5.5.).

The refrigerant of the cooling system flows through the evaporator coil located in the circulating reservoir. The water circulating in the reservoir flows over the evaporator coil and is cooled.

The cooling system is operational whenever the control system calls for a decrease in the temperature of the water in the BLANKETROL III equipment. It is important to note that the rate of change in the temperature of the water in the BLANKETROL III equipment is not directly proportional to the rate of change in the temperature of the patient.

1-5.4. Circulating System

The BLANKETROL III circulating water system is composed of a magnetically driven circulating pump, a dual compartment reservoir, a water filter, quick-disconnect fittings, connecting hose, an internal by-pass, a flow switch, a flow indicator, and hyper-hypothermia blanket(s).

The 2-gallon (7.6 liters) capacity dual compartment reservoir is composed of the circulating reservoir situated under and connected to the replenishing reservoir. When the operator fills the reservoir with Sterile water or water that has been passed through a filter less than or equal to 0.22 microns, the circulating reservoir fills first and holds approximately ½ gallon (1.9 liters) of water. The remaining 1½ gallons (5.7 liters) are held in the replenishing reservoir. The water moves from the replenishing reservoir to the circulating reservoir as needed.

The circulating water flows over and around the heating/cooling element located in the circulating reservoir. The heated or cooled water then flows out of the reservoir to the circulating pump, through connecting hoses over a water temperature sensor to the hyper-hypothermia blanket(s). The water circulates through the blanket(s) and returns to the unit. The water then passes through the water flow indicator, through the water filter, through the flow switch, and returns to the circulating reservoir to be re-heated or re-cooled and then recycled.

An internal by-pass inside the BLANKETROL III by-passes the quick-disconnect fittings, the flow indicator, the water filter, and the flow switch for water circulation during preconditioning of the water.

The circulating water system contains a flow switch to alert the operator when an occlusion prevents water flow through the blanket(s). The flow switch will only activate an alarm when flow is interrupted after normal flow has been detected. Therefore, the operator should check the flow indicator for proper flow when operation is first begun.

In addition, the replenishing reservoir contains a low water level sensor which shuts down the unit and sounds the alarm if the water level drops below a preset amount. The unit becomes operational only after the water level is restored to normal. (After the unit is refilled with water, the system must be returned to the previous operational settings.)

1-5.5. Temperature Safety Control System

The BLANKETROL III System is designed to carefully measure and control the temperature of the water in the BLANKETROL III equipment. The system is engineered so that when the temperature of the water in the BLANKETROL III equipment reaches the desired Set Point temperature, the unit cycles between heating and cooling the water in order to maintain the Set Point temperature. The unit is designed not to exceed or fall below the desired temperature.

As a safety precaution, the BLANKETROL III System has three high temperature safety devices and two low temperature safety devices.

Each safety device continuously monitors the temperature of the water in the BLANKETROL III equipment. As an additional precaution, if the water temperature sensor itself should fail, the unit shuts down and indicates SENSOR FAULT REMOVE FROM SERVICE. With this safety design, both the patient and the unit are protected from injury or damage caused by extreme temperatures.

The operator must regularly monitor the patient (according to hospital/institution policy/protocol) whenever hyper-hypothermia therapy is used.

SAFETY CONTROLS FOR PROTECTION FROM HIGH TEMPERATURE

The microprocessor controls the temperature when the water in the BLANKETROL III equipment reaches $42.0^{\circ}\text{C} \pm 0.5^{\circ}\text{C}$ ($107.6^{\circ}\text{F} \pm 1.0^{\circ}\text{F}$).

If water in the BLANKETROL III equipment reaches $44.0^{\circ}\text{C} \pm 2.0^{\circ}\text{C}$ ($111.2^{\circ}\text{F} \pm 3.6^{\circ}\text{F}$), the safety device shuts off the unit, the Status Display flashes HIGH LIMIT REMOVE FROM SERVICE and the trouble alarm sounds.

If software fails and water in the BLANKETROL III equipment reaches $44.0^{\circ}\text{C} \pm 2.0^{\circ}\text{C}$ ($111.2^{\circ}\text{F} \pm 3.6^{\circ}\text{F}$), the back-up safety device shuts off the unit, Status Display flashes HIGH LIMIT REMOVE FROM SERVICE, and the trouble alarm sounds.

If the reservoir water temperature reaches $46.0^{\circ}\text{C} \pm 2.0^{\circ}\text{C}$ ($114.8 \pm 3.6^{\circ}\text{F}$), the thermostatic snap disc shuts down the unit, Status Display flashes SNAP DISC REMOVE FROM SERVICE, the patient display indicates EE02, and the trouble alarm sounds.

SAFETY CONTROLS FOR PROTECTION FROM LOW TEMPERATURE

The microprocessor controls the temperature when the water in the BLANKETROL III equipment reaches $4.0^{\circ}\text{C} \pm 0.5^{\circ}\text{C}$ ($39.2^{\circ}\text{F} \pm 1.0^{\circ}\text{F}$).

If the water in the BLANKETROL III equipment reaches $2.0^{\circ}\text{C} \pm 2.0^{\circ}\text{C}$, ($35.6^{\circ}\text{F} \pm 3.6^{\circ}\text{F}$), the safety device shuts off the unit, the Status Display indicates LOW LIMIT REMOVE FROM SERVICE, and the trouble alarm sounds.

If software fails and water in the BLANKETROL III equipment reaches $2.0^{\circ}\text{C} \pm 2.0^{\circ}\text{C}$, ($35.6^{\circ}\text{F} \pm 3.6^{\circ}\text{F}$), the back-up safety device shuts off the unit, the Status Display indicates LOW LIMIT REMOVE FROM SERVICE, and the trouble alarm sounds.

1-5.6. USB Port Operation

Refer to GENTHERM manual 57059 for instructions and usage of the BLANKETROL III Data Export Software.

CAUTION

- Do not make any connection to the USB port terminal while the device is also connected to a patient. Do not touch this connector and the patient at the same time. Patient injury may result.

WARNING

- The USB connection on the BLANKETROL III unit is intended for data transfer to a computer. **Any other uses/connections may result in damage to the BLANKETROL III unit.**

SECTION 2. GENERAL PREPARATION OF THE BLANKETROL III SYSTEM

2-1. INTRODUCTION

This section describes the procedures to prepare the BLANKETROL III System for general use. This entails unpacking the shipment, arranging all the equipment for the first time, and completing a test routine. This section also outlines the bactericidal agent preparations, standard safety precautions, and patient preparation/bedside care when using the hyper-hypothermia blanket(s). Technical support is available upon request.

2-2. UNPACKING THE SHIPMENT

WARNING

- Remove the BLANKETROL III from service if the outer casing or membrane control panel is cracked or internal components are exposed. **Contact with internal components could result in electric shock to the patient or operator and exposure to sharp edges.**

Cut the bands at the bottom of the carton. Lift off the cardboard box and lift the unit from the cardboard insert. Locate and remove the envelope containing the manual.

During the unpacking process, look carefully for signs of shipping damage. If any unacceptable damage is found, notify the transportation company immediately and file a claim. The transportation company is responsible for the shipment after it leaves the factory. If problems other than shipping damage are found, notify your Gentherm representative or the Factory.

2-3. FIRST TIME SET-UP/SYSTEM TEST ROUTINE

CAUTION

- If the unit was shipped on its side, permit the unit to rest in an upright position for twelve (12) hours before operating due to refrigeration oil displacement.

This section describes the tasks necessary to inspect and arrange the equipment for the first time after unpacking and describes a System Test Routine to check out the membrane control panel.

The System Test Routine can also be used to teach operators unfamiliar with the equipment how to use the unit.

2-3.1. Inspecting and Arranging the Equipment

- A. Place the BLANKETROL III System in an uncluttered work space that is accessible to the correct power source with an ambient temperature between 15°C – 30°C (59°F – 86°F). Position the unit so that the membrane control panel faces the operator.
- B. Visually inspect the BLANKETROL III System to determine that there are no missing parts, unusual dents, or punctures.
- C. Examine the power cord for cuts or exposed wires and the power plug for bent or missing prongs.
- D. Review Section (1-3.) to identify the features of the BLANKETROL III System.
- E. Collect and arrange the following equipment and supplies:
 1. Hyper-hypothermia blanket(s) described in Section (1-4.) and listed in Table(6-8.).
 2. Connecting hose with quick-disconnect fittings if using disposable blanket(s).

3. 400 Series Thermistor Probes / Connecting cables described in Section (1-4.) and listed in Table (6-8.).

CAUTION

- Use Sterile water or water that has been passed through a filter less than or equal to 0.22 microns only. Do Not Use distilled water. Do Not Use De-ionized water. De-ionized water may cause corrosion to plumbing system components. Do Not Use Tap Water. Minerals and deposits can clog plumbing system components.
- **Do not** use alcohol. Alcohol may cause blanket deterioration.
- **Do not** overfill. Overfilling may result in overflow when the water in the blanket drains back into the system when the system is turned off.

- F. Lift the lid of the water fill opening and gradually pour approximately 2 gallons (7.6 liters) of Sterile water or water that has been passed through a filter less than or equal to 0.22 microns into the reservoir. Stop pouring when the water reaches the strainer visible at the bottom of the water fill opening.

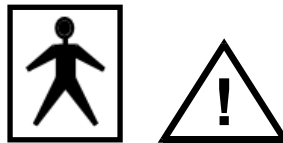

- G. The BLANKETROL III and the blanket (applied part) are BF rated as a system. Contact with other parts (i.e. the quick-disconnect fittings) at the same time as contacting the patient will negate the type of BF rating.
- H. Connect the blanket(s) to the unit by attaching the quick-disconnect female fitting of the connecting hose to a male outlet coupling (on the bottom row) of the unit. Attach the male quick-disconnect fitting of the connecting hose to a female return coupling (on the top row) of the unit. Each blanket must be connected to one outlet and one return.
- I. To attach the couplings:
1. Grasp the female coupling of the connecting hose
 2. Slide the collar back towards the hose
 3. Push the female coupling over a male coupling of the unit
 4. Allow the collar to SNAP into place and return to its original position
 5. Gently pull on the connecting hose to assure a positive connection
 6. Next, push back the collar of a female return hose on the unit with one hand
 7. With the other hand, insert the male coupling of the connecting hose
 8. Release the collar of the female return coupling
 9. Push the male coupling until it SNAPS into position
 10. Gently pull the connecting hose to assure a positive connection
- J. Check that the blanket is laying flat and that the connecting hose to the unit is not twisted or pinched.
- K. Check that the power switch of the unit is in "O" position (unit is off).

WARNING

- **Do not** by-pass ground lug (230V System). **Electrical hazards may result.**

- L. Connect the plug to a properly grounded hospital grade receptacle.

2-3.2. Completing a System Test Routine

After arranging the equipment described in Section (2-3.1.), complete this System Test Routine which describes what switches to press and the changes to observe.

NOTE: If power is removed from the unit without actuating the power switch (I/O switch) a power fail alarm is activated and the Power fail symbol LED located on the membrane control panel flashes. To stop alarm, restore power to the unit and push the SILENCE ALARM button.

- A. Make sure that the power switch is in the "I" position (unit is turned on).
 - 1. The switch illuminates green.
 - 2. The microprocessor board goes through self-test.
 - 3. The Status Display in the center of the membrane control panel flashes CHECK SETPT.

If the above are not observed, consult the Troubleshooting Guide in Section (5-20.). If they are observed, continue with the test routine.

- B. Press and hold the TEST INDICATOR button.
 - 1. The alarm produces a beep
 - 2. The LED's in the corner of the buttons and the low water and power interruption LED's flash on and then off.
 - 3. All the displays flash.

The operator should note that all the displays and indicators illuminate. If they do not illuminate, consult the Troubleshooting Guide in Section (5-20.). If they illuminate, continue with the test routine. The Status Display continues to flash CHECK SETPT.

- C. Press the TEMP SET button.
 - 1. The microprocessor board beeps.
 - 2. The LED in the corner of the button illuminates.
 - 3. The Status Display shows:
SET TEMPERATURE
SETPT 37.0°C
- D. **ENGLISH MEMBRANE ONLY:** Press the C/F button.
 - 1. The SETPT temperature displayed in the Status Display changes from 37°C to 98.6°F.
- E. Press the MONITOR ONLY button.
 - 1. The LED in the corner of the MONITOR ONLY switch illuminates
 - 2. An alarm sounds.
 - 3. The Status Displays CHECK PROBE because no probe is attached.
- F. Press the TEMP SET switch.
 - 1. The microprocessor board beeps once and the alarm stops sounding.
 - 2. The LED in the corner of the button illuminates.
 - 3. The Status Display shows:
SET TEMPERATURE
SETPT 37.0°C

NOTE: Set point may be displayed in Fahrenheit.

IN ORDER TO CHANGE FROM ONE MODE TO ANOTHER, THE TEMP SET BUTTON MUST BE PRESSED BEFORE THE NEXT MODE CAN BE SET. For example; to change from *MONITOR ONLY MODE* to *MANUAL CONTROL MODE*, the TEMP SET button must be pressed first before the *MANUAL CONTROL MODE* button can be pressed.

- G. Press the MANUAL CONTROL switch.
 - 1. The microprocessor board beeps.
 - 2. The LED in the corner of the button illuminates.

3. The WATER display shows the temperature of the water in the reservoir.
4. The Status Display shows:
* XXXXXX WATER
MANUAL SETPT 37.0 C

Or Status Display shows:

WATER @SETPT
MANUAL SETPT 37.0 C

* ("XXXXXX" represents "HEATING" or "COOLING".)

The above depends upon the relationship of the blanket water temperature to the Set Point temperature. Note that the Set Point may be displayed in Fahrenheit.

5. The pump is activated.
6. The heater or compressor may be activated.
7. The water flow indicator on the right side panel begins to move. The water moves from the unit through the blanket and returns to the unit.

If at any time the water falls below a preset limit, the Low Water sensor is activated and the Status Display flashes LOW WATER and the alarm sounds. The unit shuts down and the operator cannot proceed until this is corrected. (Use Sterile water or water that has been passed through a filter less than or equal to 0.22 microns only.)

CAUTION

- **Use Sterile water or water that has been passed through a filter less than or equal to 0.22 microns only. Do Not Use distilled water. Do Not Use De-Ionized water. De-Ionized water may cause corrosion to plumbing system components. Do Not Use Tap Water. Minerals and deposits can clog plumbing system components.**
- **Unapproved blankets or hoses should never be used.**

WARNING

- Any time water is found leaking into or around the unit, connecting hose, and/or blanket, turn the unit off, disconnect the power cord from its power source, and correct the problem before proceeding. Proper maintenance procedures should be followed including, but not limited to, the preventative maintenance described in this manual. Leaky blankets or hoses should never be used. **Water leaks could present a slip hazard and risk of infection and could lead to electric shock.**
- Prep solutions have been reported to injure the skin when allowed to remain between patients and a water-circulating heating blanket during prolonged procedures. Use of materials of good thermal conductivity, such as water, gel, and similar substances, with the BLANKETROL III not switched ON may decrease the temperature of the patient. **The area between the patient and the blanket should be kept dry to avoid injury to patient.**

- H. Check the blanket for leaks. If a leak is found, the blanket cannot be used.
- I. Check the couplings at the unit and at the blanket for positive connection.
- J. Press the TEMP SET switch
 1. The microprocessor board beeps.
 2. The LED in the corner of the switch illuminates.
 3. The indicator light left of the Set point display goes out.
 4. The Blanket/Water display goes blank.
 5. The Status Display shows:
SET TEMPERATURE

SETPT 37.0°C

NOTE: Set point may be displayed in Fahrenheit.

6. The pump shuts down, the heating/cooling stops.

When the TEMP SET button is pressed, the operating mode (e.g. *MANUAL CONTROL MODE* or any of the Automatic Modes) is cancelled. The operator is once again at the beginning of the mode selection procedure.

- K. Press the Up arrow next to the TEMP SET button.
 1. The microprocessor board beeps each time it is pressed.
 2. The Set Point display changes; the numbers move up the scale. The longer the button is pressed the faster the digits change. When the button is released and repressed, the digits once again change slowly and then increase in speed. The highest setting is 42°C or 107.6°F.
- L. Press the Down arrow next to the TEMP SET button.
 1. The microprocessor board beeps each time it is pressed.
 2. The Set Point display changes; the numbers move down the scale. The longer the button is pressed the faster the digits change. When the button is released and repressed, the digits once again change slowly and then increase in speed. The lowest setting is 4°C or 39.2°F.
- M. Press the Up arrow or Down arrow so that the SET POINT display shows a number between 30°C - 40°C (86°F - 104°F). For example, set the display to show 32.3°C or 90°F.
- N. Connect a 400 Series probe to the 1/4 inch receptacle on the right side of the unit.
- O. Press the AUTO CONTROL button.
 1. The alarm sounds.
 2. The Status Display flashes CHECK PROBE.

The alarm sounds because the patient probe, as held by the operator in the open air, for this test routine, detects a reading below 30°C (86°F). The unit will not operate in the *AUTO CONTROL MODE* unless the probe is properly placed on a patient and reading between 30°C – 43.5°C (86°F - 110.3°F).

- P. Press the SILENCE ALARM button.
 1. The alarm stops
 2. The Status Display continues to flash CHECK PROBE

The Operator has 5 minutes to correct the problem. In an actual situation, the operator would check the probe and then continue operation.

- Q. Press the TEMP SET button.
 1. The microprocessor board beeps.
 2. The LED in the corner of the button illuminates.
 3. The Status Display returns to set temperature mode.
- R. Press the Up arrow or the Down arrow so that the Set point display shows a number less than 30°C (86°F) or greater than 40°C (104°F).
- S. Press the AUTO CONTROL button.
 1. The Set point display goes blank.
 2. The Status Display flashes CHECK SETPT.

The display flashes because the Set point temperature is outside the *AUTOMATIC CONTROL MODE* temperature range of 30°C - 40°C (86°F - 104°F). The unit will not operate in any of the Automatic Modes unless the Set point display shows a number within the range.

- T. Press the TEMP SET button
1. The microprocessor board beeps.
 2. The LED in the corner of the button illuminates.
 3. The Status Display returns to set temperature mode.
- U. Press the Up arrow or the Down arrow so that the Set point displays 37°C (98.6°F). Set the patient probe to a temperature reading between 30°C – 43.5°C (86°F -110.3°F).
- V. Press the AUTO CONTROL button.
1. The microprocessor board beeps.
 2. The LED in the corner of the button illuminates.
 3. The WATER display shows the temperature of the water in the reservoir.
 4. The Status Display shows:
 - * XXXXXX PATIENT
 - AUTO SETPT 37.0 C
 Or Status Display shows:
 - PATIENT @SETPT
 - AUTO SETPT 37.0 C

* (“XXXXXX” represents “HEATING” or “COOLING”).

The above depends upon the relationship of the patient temperature to the Set Point temperature. Note that the Set Point may be displayed in Fahrenheit.

5. The pump is activated.
 6. The heater or compressor may be activated.
 7. The water flow indicator on the right side panel begins to move. The water moves from the unit through the blanket and returns to the unit.
 8. System operates in AUTO CONTROL mode.
- W. Press TEMP SET button
1. The microprocessor board beeps.
 2. The LED in the corner of the button illuminates.
 3. The Status Display returns to set temperature mode.
- X. Press GRADIENT 10C button and then SMART button
1. The microprocessor board beeps.
 2. The LED’s in the corner of the buttons illuminate.
 3. The WATER display shows the temperature of the water in the reservoir.
 4. The Status Display shows:
 - * XXXXXX PATIENT
 - AUTO SETPT 37.0 C
 Or Status Display shows:
 - PATIENT @SETPT
 - AUTO SETPT 37.0 C

* (“XXXXXX” represents “HEATING” or “COOLING”).

The above depends upon the relationship of the patient temperature to the Set Point temperature. Note that the Set Point may be displayed in Fahrenheit.

5. The pump is activated.
6. The heater or compressor may be activated.
7. The water flow indicator on the right side panel begins to move. The water moves from the unit through the blanket and returns to the unit.
8. Wait 30 minutes for SMART MODE to occur.

9. System operates in GRADIENT 10C SMART mode.
- Y. Press TEMP SET button
1. The microprocessor board beeps.
 2. The LED in the corner of the button illuminates.
 3. The Status Display returns to set temperature mode.
- Z. Press the GRADIENT VARIABLE button
1. The microprocessor board beeps.
 2. The LED in the corner of the button illuminates.
 3. The Status Display shows:
VARIABLE GRADIENT
OFFSET 0 C
- AA. Press the Up arrow or Down arrow to change the gradient variable offset to the desired value.
1. The microprocessor board beeps.
 2. The offset in the Status Display changes.
- AB. Press the GRADIENT VARIABLE button and then SMART button
1. The microprocessor board beeps.
 2. The LED in the corner of the button illuminates.
 3. The Patient display shows the patient's actual temperature.
 4. The WATER display shows the temperature in the water reservoir.
 5. The Status Display shows either:
* XXXXXX PATIENT
AUTO SETPT 37.0 C
Or Status Display shows:
PATIENT @SETPT
AUTO SETPT 37.0 C
* ("XXXXXX" represents "HEATING" or "COOLING".)

The above depends upon the relationship of the patient temperature to the Set Point temperature. Note that the Set Point may be displayed in Fahrenheit.

6. The pump is activated.
 7. The heater or compressor may also be activated.
 8. The water flow indicator on the right side panel begins to move. The water moves from the unit to the blanket and returns to the unit.
 9. Wait 30 minutes for SMART MODE to occur.
 10. System operates in GRADIENT VARIABLE SMART mode.
- AC. Press TEMP SET button
1. The microprocessor board beeps.
 2. The LED in the corner of the button illuminates.
 3. The Status Display returns to set temperature mode.
- AD. Press the MANUAL CONTROL button.
1. The microprocessor board beeps.
 2. The LED in the corner of the button illuminates.
 3. The WATER display shows the temperature of the water in the reservoir.
 4. The PATIENT display shows the temperature reading of the probe, as it is held by the operator, if the probe reading is in the range of 10°C - 50°C (50°F - 122°F).
 5. The Status Display shows either:
* XXXXXX WATER
MANUAL SETPT 37.0 C

Or Status Display shows:
WATER @SETPT
MANUAL SETPT 37.0 C

* ("XXXXXX" represents "HEATING" or "COOLING".)

The above depends upon the relationship of the blanket water temperature to the Set Point temperature. Note that the Set Point may be displayed in Fahrenheit.

6. The pump is activated.
7. The heater or compressor may be activated.
8. The water flow indicator on the right side panel begins to move.

The preceding step is included to show that the patient display illuminates when the probe is connected and the system is in the *MANUAL CONTROL MODE* as well as when the system operates in any of the Automatic Modes.

AE. Press TEMP SET button

1. The microprocessor board beeps.
2. The LED in the corner of the button illuminates.
3. The Status Display returns to set temperature mode.

AF. To complete this test routine, turn the power switch off.

1. The membrane control panel goes blank.
2. The green light of the power switch goes out.

AG. Remove the 400 Series probe from the 1/4 inch receptacle on the right side of the unit.

AH. Disconnect the power cord from the power source, loosely coil it and attach it to the back panel using the nylon strap.

AI. For reusable - PLASTIPAD - blankets, disconnect the connecting hose from the unit. Loosely coil the hose lengthwise in the center of the blanket. Fold the blanket lengthwise into the center, 1/3 from the left side and 1/3 from the right side. To drain the water from the reusable blanket simply shut off power to the unit or shut off the operation of the manual or automatic mode and allow the water to drain from the blanket back into the BLANKETROL III unit.

For single-use blankets, follow the instructions packaged with the blanket. The water should be changed quarterly as described in Section (4-2.).

The BLANKETROL III unit, connecting hose, blanket(s), and probe are now ready for patient use.

2-4. UNIT AND PATIENT RELATED PRECAUTIONS

This unit requires both water and electricity to operate.

Please consult pages 4 through 7 at the beginning of the manual for a complete list of warnings and cautions related to the BLANKETROL III.

- A. Anytime the unit sounds an alarm, the operator should immediately check the Status Display and act accordingly, e.g., add water, remove from service, check the probe, etc.
- B. The BLANKETROL III unit is equipped with a circuit breaker in the I/O (on/off) power switch to protect against current overload.

2-5. PATIENT PREPARATION AND BEDSIDE CARE

Effective use of the BLANKETROL III System must include proper patient care prior to and while using the hyper-hypothermia blanket(s).

WARNING

- A physician's order is required for setting blanket temperature and use of equipment. At least every 20 minutes, or as directed by physician, check patient's temperature and skin integrity of areas in contact with blanket; also, check the BLANKETROL III's water temperature. Pediatric patients, temperature-sensitive patients with vascular disease, surgical patients, diabetics and patients with Raynaud's Disease are at a greater risk for developing tissue injuries, and this should be considered when selecting the temperature, duration of therapy and frequency of skin checks. **Notify the physician promptly of any change in patient status to avoid serious injury or death.**
- The method of temperature control provided by all hyper-hypothermia units presents the danger of heating or cooling body tissues, particularly the skin, to a point where they are injured, i.e., burns or frostbite, respectively. The clinician is responsible for determining the appropriateness of the temperature limits in dependency to time. **Exceeding 40°C water temperature for extended periods can cause tissue damage and burns. Clinical judgment should be used to determine the safe maximum contact periods based on patient age, clinical condition, and current medications. Depending on the extent and severity of a burn, very serious and even fatal complications may arise.**
- Do not use the BLANKETROL III System distal to arterial cross clamping. **Thermal injury may result.**
- **Thermal injury may occur** if heating/cooling therapy is applied to ischemic limbs.
- The warming of transdermal medications (patches) can increase drug delivery, **resulting in possible injury to the patient.**
- Prevent excessive and/or prolonged tissue pressure and shearing forces, especially over bony prominences. **Failure to do so may result in tissue injury.**
- Do not place additional heat sources between the patient and blanket. **Tissue damage may result.**
- Means to maintain contact between the patient and the blanket during therapy may be required and should not block the fluid pathways of the blanket or connecting hose. **Failure to do so may result in inadequate treatment.**
- Prep solutions have been reported to injure the skin when allowed to remain between patients and a water-circulating heating blanket during prolonged procedures. Use of materials of good thermal conductivity, such as water, gel, and similar substances, with the BLANKETROL III not switched ON may decrease the temperature of the patient. **The area between the patient and the blanket should be kept dry to avoid injury to patient.**
- Proper sanitation procedures must be practiced and hygienic safety must be maintained, to prevent contamination. **Contamination can affect patient's health, i.e. skin irritation/rash may result.**
- Use only YSI 400 Series, or equivalent, probes on GENTHERM equipment (refer to Table (6-8)). **Failure to do this will cause incorrect temperature readings and may result in inadequate/inappropriate treatment.**
- Due to static electricity, a 400 Series Probe may not be connected to the BLANKETROL III unit without first discharging one's body to the frame of the BLANKETROL III unit or another grounded object. **Failure to do so may result in damage from electrostatic discharge (ESD).** All staff that may touch the 400 Series Probe must be familiar with this warning and basic static electricity or electrostatic discharge (ESD) training.

WARNING

<ul style="list-style-type: none"> Basic static electricity or ESD training should include an introduction to the physics of electrostatic charge, the voltage levels that can occur in normal practice and the damage that can be done to electronic components if equipment is touched by an operator who is electrostatically charged. Further, an explanation should be given of methods to prevent build-up of electrostatic charge, and how and why to discharge one's body to the BLANKETROL III unit or another grounded object. Failure to do so may result in damage from electrostatic discharge (ESD).
<ul style="list-style-type: none"> Do not use the BLANKETROL III system in the presence of flammable anesthetics. Risk of explosion can result.
<ul style="list-style-type: none"> Remove the BLANKETROL III from service if the outer casing or membrane control panel is cracked or internal components are exposed. Contact with internal components could result in electric shock or thermal injury to the patient or operator and exposure to sharp edges.
<ul style="list-style-type: none"> Keep grill and condenser clean and free of debris and obstruction. Blockage of the grill and condenser could result in the unit overheating which could render the unit unable to provide adequate therapy and excessive surface temperatures could cause injury of patient or operator. Keep unit, specifically the grill away from curtains or other obstructions.
<ul style="list-style-type: none"> The USB connection on the BLANKETROL III unit is intended for data transfer to a computer. Any other uses/connections may result in damage to the BLANKETROL III unit.
<ul style="list-style-type: none"> Working with electronic boards, plugs, and cables requires delicate handling. Proper electrostatic discharge (ESD) procedures should be followed during replacement of any electronic board. Failure to do so may result in damage to the board.
<ul style="list-style-type: none"> If unit requires repair, do not attempt to fix unit on your own. Only qualified personnel should perform repairs. Damage to the unit or malfunction may otherwise result.
<ul style="list-style-type: none"> Use of accessories other than those specified in Table 6-8 may result in increased electromagnetic emissions or decreased immunity to electromagnetic emissions of the BLANKETROL III unit. This could affect the BLANKETROL III's compatibility with other electrical equipment. Electromagnetic compatibility refers to electronic devices unintentionally affecting the operation of each other by emitting electromagnetic energy.
<ul style="list-style-type: none"> Power interruption will cause the BLANKETROL III to revert to CHECK SET POINT resulting in no therapy to the patient. Follow instructions for desired mode to resume operation. Failure to resume therapy could result in serious injury or death.
<ul style="list-style-type: none"> Do not by-pass ground lug (230V System). Electrical Hazards may result.
<ul style="list-style-type: none"> To avoid the risk of electric shock, this equipment must only be connected to a supply mains with protective earth. Risk of electrical shock may occur.
<ul style="list-style-type: none"> Blanket punctures can result in an increased risk of infection or electrical shock. Inspect all blankets for mechanical damage before use. Do not use in proximity to sharp objects.
<ul style="list-style-type: none"> Any time water is found leaking into or around the unit, connecting hose, and/or blanket, turn the unit off, disconnect the power cord from its power source, and correct the problem before proceeding. Proper maintenance procedures should be followed including, but not limited to, the preventative maintenance described in this manual. Leaky blankets or hoses should never be used. Water leaks could present a slip hazard and risk of infection and could lead to electric shock.
<ul style="list-style-type: none"> Exercise extreme caution if the BLANKETROL III System is used on patients with cardiac issues, for example, patients with pacemakers, or when a probe is inserted in or attached to the patient. Failure to properly monitor patient may result in serious injury or death.

WARNING

- Due to electromagnetic compatibility, the BLANKETROL III unit should not be used adjacent to or stacked with other equipment. **Potential electromagnetic interference may result.** Other equipment includes ventilators, patient monitors, anesthesia delivery equipment, etc. Electromagnetic interference refers to electronic devices unintentionally affecting the operation of each other by emitting electromagnetic energy. Unit complies with IEC 60601-1-2.
- If the BLANKETROL III unit or the other equipment is not operating normally, remove the device from service and have a biomedical or service technician observe the device in operation. Refer to Section 7 for recommended separation distances between other equipment and the BLANKETROL III. **Failure to do so may result in damage to the BLANKETROL III system and patient injury.**
- Always **unplug the unit** before accessing internal components during service. **Failure to unplug the unit could result in electric shock.**
- The repair, calibration, and servicing of the BLANKETROL III should be performed by qualified Medical Equipment Service Technicians, Certified Biomedical Electronics Technicians, or Certified Clinical Engineers familiar with good repair practices for servicing medical devices, and in accordance with instructions contained in this manual. **Improper repair can result in damage to the BLANKETROL III system and patient injury.**
- No modification of this equipment is allowed without prior, written authorization from GENTHERM. **Failure to do so may result in damage to the BLANKETROL III system and patient injury.**
- **Before** returning the BLANKETROL III to patient use **after** repairs, the FIRST TIME SET-UP/SYSTEM TEST ROUTINE in Section 2 must **always** be performed. **Improper repair and inadequate maintenance can result in damage to the BLANKETROL III system and patient injury.**

CAUTION

- Federal law restricts this device to sale by or on the order of a physician.
- **Use Sterile water or water that has been passed through a filter less than or equal to 0.22 microns only. Do Not Use distilled water. Do Not Use De-ionized water. De-ionized water** may cause corrosion to plumbing system components. **Do Not Use Tap Water. Minerals and deposits** can clog plumbing system components.
- **Do not** use alcohol. Alcohol may cause blanket and unit deterioration.
- Use only hospital grade plug or electric shock may result.
- **Do not** overfill. Overfilling may result in overflow when the water in the blanket drains back into the system when the system is turned off.
- Always drain the BLANKETROL III to a sanitary drain because **bio-contaminants** may be present in the unit's water supply.
- Handling or use of the patient probe may result in damage from **electrostatic discharge (ESD)** if proper precautions are not taken.
- All wire-lead, patient-connected transducer assemblies are subject to reading error, local heating, and possible damage from high intensity sources of RF energy. Inadequately grounded electrosurgical equipment represents one such source, since capacitively coupled currents may seek alternate paths to ground through probe cables and associated instruments. Patient burns may result. If possible, remove the probe from patient contact before activating an electrosurgical unit.
- **Do not** immerse probes or connecting cables in liquid. Failure to do so may result in damage to the probes.

CAUTION

- If the unit was shipped on its side, permit the unit to rest in an upright position for twelve (12) hours before operating due to refrigeration oil displacement.
- For safe handling and use of chemicals follow manufacturer guidelines.
- Do not make any connection to the USB port terminal while the device is also connected to a patient. Do not touch this connector and the patient at the same time. Patient injury may result.
- Users should not use cleaning or decontamination methods different from those recommended by GENTHERM without first checking with GENTHERM that the proposed methods will not damage the equipment.
- Working with electronic boards, plugs, and cables requires delicate handling. Proper **electrostatic discharge (ESD)** procedures should be followed during replacement of any electronic board. **Failure to do so may result in damage to the board.**
- If device is set to operate in any Automatic mode, the device will shut down and activate the CHECK PROBE alarm if the patient temperature falls below 30.0°C (86°F). Patient temperature must rise above 30.0°C (86°F) before restarting the device in Automatic mode. The device can be operated in Manual Control mode in order to warm the patient above 30.0°C (86°F). Potential for interruption of therapy.
- **Unapproved blankets or hoses should never be used.**
- **Do not use GRADIENT VARIABLE MODE OR GRADIENT 10C MODE without SMART MODE. Unintended therapy could occur.**

A dry sheet should be placed between the hyper-hypothermia blanket and the patient when using PLASTI-PAD, or MAXI-THERM Blankets. The MAXI-THERM LITE Blanket does not require an interposed sheet.

While using a hyper-hypothermia blanket include the following tasks:

- A. A physician's order is required for setting blanket temperature and use of equipment. At least every 20 minutes, or as directed by physician, check patient's temperature and skin integrity of areas in contact with blanket; also, check the BLANKETROL III's water temperature. Pediatric patients, temperature-sensitive patients with vascular disease, surgical patients, diabetics and patients with Raynaud's Disease are at a greater risk for developing tissue injuries, and this should be considered when selecting the temperature, duration of therapy and frequency of skin checks. **Notify the physician promptly of any change in patient status in order to avoid serious injury or death.**
- B. The position and the placement of the 400 Series probe should be inspected regularly. Also, the BLANKETROL III System activates an alarm in the automatic modes when the patient probe registers outside the range of 30°C - 43.5°C (86°F - 110.3°F).
- C. Changes in skin color, edema, inflammation, or indications of pressure, especially over bony prominences, should be noted and treated promptly as ordered. Avoid prolonged tissue pressure and shearing forces over bony prominences.
- D. The patient should be turned and properly re-positioned according to hospital/institution policy/protocol.

SECTION 3. OPERATING THE BLANKETROL III SYSTEM

3-1. INTRODUCTION

This section describes how to operate the BLANKETROL III System in order to control a patient's temperature. First, collect the equipment and prepare the patient. Second, decide which mode of operation to use. Third, set the appropriate controls: *AUTOMATIC CONTROL MODE*, *MANUAL CONTROL MODE*, *GRADIENT 10C SMART MODE*, *GRADIENT VARIABLE SMART MODE*, or *MONITOR ONLY MODE*.

For proper knowledge and understanding of the unit, in-service is available upon request.

3-2. ARRANGING THE SYSTEM COMPONENTS

- A. Collect all supplies and equipment
1. BLANKETROL III unit
 2. Hyper-hypothermia blanket(s)
 3. Dry sheet or bath blanket
 4. Connecting hose, if using Disposable Blanket(s)
 5. 400 Series probe (refer to Table (6-8.).
 6. Connecting cable (if using disposable probes)
 7. Sterile water or water that has been passed through a filter less than or equal to 0.22 microns

WARNING

- Due to electromagnetic compatibility, the BLANKETROL III unit should not be used adjacent to or stacked with other equipment. **Potential electromagnetic interference may result.** Other equipment includes ventilators, patient monitors, anesthesia delivery equipment, etc. Electromagnetic interference refers to electronic devices unintentionally affecting the operation of each other by emitting electromagnetic energy. Unit complies with IEC 60601-1-2.
- If the BLANKETROL III unit or the other equipment is not operating normally, remove the device from service and have a biomedical or service technician observe the device in operation. Refer to Section 7 for recommended separation distances between other equipment and the BLANKETROL III. **Failure to do so may result in damage to the BLANKETROL III system and patient injury.**

- B. Place the BLANKETROL III unit in the patient area, accessible to the correct power source, and in an ambient environment of 15°C – 30°C (59°F – 86°F).
- C. Review Section (1-3.) that outlines the features of the unit and membrane control panel.

CAUTION

- **Use Sterile water or water that has been passed through a filter less than or equal to 0.22 microns only. Do Not Use distilled water. Do Not Use De-ionized water.** De-ionized water may cause corrosion to plumbing system components. **Do Not Use Tap Water. Minerals and deposits** can clog plumbing system components.
- **Do not** use alcohol. Alcohol may cause blanket deterioration.
- **Do not** overfill. Overfilling may result in overflow when the water in the blanket drains back into the system when the system is turned off.

- D. Check the level of Sterile water or water that has been passed through a filter less than or equal to 0.22 microns in the reservoir. To do so, lift the cover of the water fill opening and check if the water is visibly touching the strainer. If needed, carefully add Sterile water or water that has been passed through a filter less than or equal to 0.22 microns. In addition, if the water falls below a preset level, the alarm sounds and the Status Display flashes LOW WATER. The operator cannot proceed until this is corrected as described in Sections (3-10-D.) and (4-2.2).
- E. Check that the power switch is in the "O" position (unit is off).
- F. Inspect the power plug for bent or missing prongs.

WARNING

- **Do not by-pass ground lug (230V System). Electrical hazards may result.**

- G. Insert the plug into a properly grounded hospital grade receptacle.
- H. Lay the hyper-hypothermia blanket flat with the hose routed, without kinks, towards the unit.
- I. If the blanket is already filled, check that there are no leaks.

WARNING

- Any time water is found leaking into or around the unit, connecting hose, and/or blanket, turn the unit off, disconnect the power cord from its power source, and correct the problem before proceeding. Proper maintenance procedures should be followed including, but not limited to, the preventative maintenance described in this manual. Leaky blankets or hoses should never be used. **Water leaks could present a slip hazard and risk of infection and could lead to electric shock.**

CAUTION

- **Unapproved blankets or hoses should never be used.**

- J. Cover the blanket with a dry sheet or bath blanket (if using PLASTI-PAD, or MAXI-THERM Blanket).
- K. Connect the blanket to the BLANKETROL III unit as described in Section (2-3.1.), Step (H.).
- L. If a single-patient use hyper-hypothermia blanket is used, connect the color coded couplings of the connecting hose to the blanket as described in the instructions packaged with each blanket.
- M. Check that the blanket is flat, and the connecting hose is not twisted or pinched.
- N. The hyper-hypothermia blanket may be pre-cooled or pre-warmed before positioning the patient. To do so, operate the system in Manual Control Mode for a few minutes.
- O. Place the patient on the hyper-hypothermia blanket.

CAUTION

- Handling or use of the patient probe may result in damage from **electrostatic discharge (ESD)** if proper precautions are not taken.

- P. If the patient's temperature is to be monitored as required in an automatic control mode or *MONITOR ONLY MODE*, insert or attach a 400 Series probe in or on the patient.

1. A rectal probe is inserted into the rectum and secured with tape to the leg of the patient.
2. The diaphragm of a skin probe is taped to the patient, usually under the patient's arm or on the chest.
3. The esophageal probe is inserted in the patient. It is often preferred that the patient is comatose or under anesthesia when the probe is placed in the esophagus.

The 400 Series probe should be inspected periodically to insure that it is not dislodged or impacted. *The BLANKETROL III System sounds an alarm when the reading from the probe falls below 30°C (86°F).*

It is important that the 400 Series probe be inserted in or attached to the patient at least three minutes before pressing a control mode button. *This will prevent the accidental triggering of the CHECK PROBE status message.*

4. The probe connecting cable is used to connect the BLANKETROL III System to disposable temperature probes.
- Q. If an upper hyper-hypothermia blanket is to be used, follow instructions in step (J).
- R. Connect the top blanket to the unit following the procedure described in Section (2-3.1.) Step (H.).
- S. If no top hyper-hypothermia blanket is used, cover the patient with a top sheet and/or blanket. Patient preparation and bedside care are further described in Section (2-5.).
- T. Choose which operating mode to use: Operating in Auto Control Mode is described in Section (3-3.). Operating in Manual Control Mode is described in Sections (3-4.) and (3-5.). Operating in GRADIENT 10C SMART MODE is described in Section (3-6.). Operating in GRADIENT VARIABLE SMART MODE is described in Section (3-7.). Operating in MONITOR ONLY MODE is described in Section (3-8.).

NOTE: The maximum contact surface temperature is 41°C.

NOTE: If at any time, power is removed from the unit without actuating the power switch (I/O switch) a power fail alarm will activate, and the Power fail symbol LED located on the membrane control panel will flash. To stop the alarm, restore power or push the SILENCE ALARM button.

In the case that the unit is powered-off for 5 seconds or less, the unit will resume the previous operation mode. However, if power is off longer than 5 seconds, the unit will go into power fail alarm mode.

3-3. OPERATING THE BLANKETROL III SYSTEM IN AUTO CONTROL MODE**WARNING**

- A physician's order is required for setting blanket temperature and use of equipment. At least every 20 minutes, or as directed by physician, check patient's temperature and skin integrity of areas in contact with blanket; also, check the BLANKETROL III's water temperature. Pediatric patients, temperature-sensitive patients with vascular disease, surgical patients, diabetics and patients with Raynaud's Disease are at a greater risk for developing tissue injuries, and this should be considered when selecting the temperature, duration of therapy and frequency of skin checks. **Notify the physician promptly of any change in patient status in order to avoid serious injury or death.**
- The method of temperature control provided by all hyper-hypothermia units presents the danger of heating or cooling body tissues, particularly the skin, to a point where they are injured, i.e., burns or frostbite, respectively. The clinician is responsible for determining the appropriateness of the temperature limits in dependency to time. **Exceeding 40°C water temperature for extended periods can cause tissue damage and burns. Clinical judgment should be used to determine the safe maximum contact periods based on patient age, clinical condition, and current medications. Depending on the extent and severity of a burn, very serious and even fatal complications may arise.**
- Due to static electricity, a 400 Series Probe may not be connected to the BLANKETROL III unit without first discharging one's body to the frame of the BLANKETROL III unit or another grounded object. **Failure to do so may result in damage from electrostatic discharge (ESD).** All staff that may touch the 400 Series Probe must be familiar with this warning and basic static electricity or electrostatic discharge (ESD) training.
- Basic static electricity or ESD training should include an introduction to the physics of electrostatic charge, the voltage levels that can occur in normal practice and the damage that can be done to electronic components if equipment is touched by an operator who is electrostatically charged. Further, an explanation should be given of methods to prevent build-up of electrostatic charge, and how and why to discharge one's body to the BLANKETROL III unit or another grounded object. **Failure to do so may result in damage from electrostatic discharge (ESD).**

CAUTION

- If device is set to operate in any Automatic mode, the device will shut down and activate the CHECK PROBE alarm if the patient temperature falls below 30.0°C (86°F). Patient temperature must rise above 30.0°C (86°F) before restarting the device in Automatic mode. The device can be operated in Manual Control mode to warm the patient above 30.0°C (86°F). Potential for interruption of therapy.
- **Do not use GRADIENT VARIABLE MODE OR GRADIENT 10C MODE without SMART MODE. Unintended therapy could occur.**

In AUTO CONTROL MODE, the BLANKETROL III System can monitor the patient's temperature and deliver the maximum heating or cooling therapy in order to bring the patient's temperature to a Set Point chosen by the operator.

After arranging the equipment as described in Section (3-2.), proceed as follows:

- Check the placement of the 400 Series probe in or on the patient.
- Connect the 400 Series probe to the 1/4 inch receptacle on the right side of the unit. If using a disposable probe, a Connecting cable is needed to connect the probe to the BIII.

- C. Press the power switch to the "I" position.
1. The switch illuminates green.
 2. The microprocessor board goes through self-test.
 3. The Status Display flashes CHECK SETPT.
- D. Consult the physician's orders to determine the desired patient Set Point temperature. As a safety precaution, the SET POINT display can only be set between 30°C - 40°C (86°F - 104°F) to operate in Automatic Control Mode.
- E. Use the C/F button to choose the desired temperature scale (English membrane only).
- F. Press the TEMP SET button.
1. The microprocessor beeps.
 2. The LED in the corner of the button illuminates.
 3. The SET POINT display shows a temperature reading.
 4. The Status Display shows SET TEMP.
- G. Press the Up arrow or Down arrow to change the SET POINT display to the desired patient temperature. The display can only be set between 30°C -40°C (86°F - 104°F) or else the system will not operate in *AUTOMATIC CONTROL MODE*.
1. The microprocessor board beeps.
 2. The Set Point on the Status Display changes.
- H. Press the AUTO CONTROL button.
1. The microprocessor board beeps.
 2. The LED in the corner of the button illuminates.
 3. The Patient display shows the patient's actual temperature.
 4. The WATER display shows the actual temperature of the water in the BLANKETROL III equipment.
 5. The Status Display indicates:
 * XXXXXX PATIENT
 AUTO SETPT 37.0 C
 Or Status Display shows:
 PATIENT @SETPT
 AUTO SETPT 37.0 C
 * ("XXXXXX" represents "HEATING" or "COOLING".)

The above depends upon the relationship of the patient temperature to the Set Point temperature. Note that the Set Point may be displayed in Fahrenheit.

6. The pump is activated. The heater or compressor may also be activated.
 7. The water flow indicator on the right side panel begins to move.
 8. The water moves from the unit to the blanket and returns to the unit.
- I. Check the water flow indicator to confirm that the water is circulating.
- J. Touch the hyper-hypothermia blanket to confirm that the blanket is heating/cooling.
- K. To make any changes in the control settings, press the TEMP SET button and begin again.

The BLANKETROL III System is now operating in Automatic Control Mode. You should continue to monitor the system and the patient. (Review the suggestions for patient care described in Section (2-5).)

If at any time the Status Display shows a message other than the messages described in Automatic Control Mode procedures, make the changes indicated by the display and/or consult the list of display messages in Section (3-10.). If at any time the unit sounds an alarm and the Status Display flashes a message, make the changes indicated.

To turn off the unit or discontinue hyper-hypothermia treatment, proceed as described in Section (3-9.).

NOTE: TO CHANGE FROM ANY CONTROL MODE TO ANOTHER CONTROL MODE, FIRST PRESS THE "TEMP SET" BUTTON, AND THEN SELECT THE OPERATING MODE OF CHOICE.

In order to change from *AUTOMATIC CONTROL MODE* to *MONITOR ONLY MODE*, press the MONITOR ONLY button.

3-4. OPERATING THE BLANKETROL III SYSTEM IN *MANUAL CONTROL MODE*

WARNING

- A physician's order is required for setting blanket temperature and use of equipment. At least every 20 minutes, or as directed by physician, check patient's temperature and skin integrity of areas in contact with blanket; also, check the BLANKETROL III's water temperature. Pediatric patients, temperature-sensitive patients with vascular disease, surgical patients, diabetics and patients with Raynaud's Disease are at a greater risk for developing tissue injuries, and this should be considered when selecting the temperature, duration of therapy and frequency of skin checks. **Notify the physician promptly of any change in patient status in order to avoid serious injury or death.**
- The method of temperature control provided by all hyper-hypothermia units presents the danger of heating or cooling body tissues, particularly the skin, to a point where they are injured, i.e., burns or frostbite, respectively. The clinician is responsible for determining the appropriateness of the temperature limits in dependency to time. **Exceeding 40°C water temperature for extended periods can cause tissue damage and burns. Clinical judgment should be used to determine the safe maximum contact periods based on patient age, clinical condition, and current medications. Depending on the extent and severity of a burn, very serious and even fatal complications may arise.**

The BLANKETROL III System can be set so that it operates based upon the actual temperature of the water in the BLANKETROL III equipment relative to the Set Point temperature.

In *MANUAL CONTROL MODE* the BLANKETROL III System does not read the patient's temperature, so the unit will not adjust the temperature of the water in the BLANKETROL III equipment accordingly. Because of this, special care must be taken to monitor the patient's temperature. And, as in all cases, the patient's skin integrity must be closely monitored

After arranging the equipment as described in Section (3-2.), proceed as follows:

- A. Press the power switch to the "I" position.
 1. The switch illuminates green.
 2. The microprocessor board goes through self-test.
 3. The Status Display flashes CHECK SETPT.
- B. Consult the physician's orders to determine the desired patient Set Point temperature and the desired water temperature setting.
- C. Press the TEMP SET Switch.
 1. The microprocessor board beeps.
 2. The LED in the corner of the button illuminates.
 3. The SET POINT display shows a temperature reading.
 4. The Status Display shows SET TEMP.
- D. Use the C/F button to choose the desired temperature scale (English membrane only).

- E. Press the Up arrow or Down arrow to change the SETPOINT display to the desired Blanket/Water Set Point temperature. As a safety precaution, the Blanket/Water temperature in the device can only be set between 4°C - 42°C (39.2°F - 107.6°F).
1. The microprocessor board beeps.
 2. The Status Display changes.
- F. Press the MANUAL CONTROL switch.
1. The microprocessor board beeps.
 2. The LED in the corner of the button illuminates.
 3. The BLANKET/WATER display shows the actual temperature of the water in the BLANKETROL III equipment.
 4. The Status Display shows:

```
* XXXXXX WATER
  MANUAL      SETPT 37.0 C
```

 Or Status Display shows:

```
WATER @SETPT
  MANUAL      SETPT 37.0 C
```

 * ("XXXXXX" represents "HEATING" or "COOLING".)

The above depends upon the relationship of the blanket water temperature to the Set Point temperature. Note that the Set Point may be displayed in Fahrenheit.

5. The pump is activated. The heater or compressor may be activated.
 6. The Water Flow indicator on the right side panel begins to move.
 7. The water moves from the unit through the blanket and returns to the unit.
- G. Check the water flow indicator to confirm that the water is circulating.
- H. Touch the hyper-hypothermia blanket to confirm that the blanket is heating/cooling.
- I. To make any changes in the control setting, press the TEMP SET button and begin again.

The BLANKETROL III System is now operating in Manual Control Mode. The operator must continue to monitor the change in the patient's temperature. (Review the suggestions for patient care described in Section (2-5).)

If at any time the Status Display shows a message other than the messages described in Manual Control MODE procedures, make the changes indicated by the display and/or consult the list of display messages in Section (3-10.). If at any time the unit sounds an alarm and the Status Display flashes a message, make the changes as indicated.

To turn off the unit or discontinue hyper-hypothermia treatment, proceed as described in Section (3-9.).

NOTE: IN ORDER TO CHANGE FROM A MANUAL CONTROL MODE TO ANOTHER CONTROL MODE, FIRST PRESS THE "TEMP SET" BUTTON, AND THEN SELECT THE OPERATING MODE OF CHOICE.

In order to change from *MANUAL CONTROL MODE* to *MONITOR ONLY MODE*, simply press the MONITOR ONLY button.

3-5 OPERATING THE BLANKETROL III SYSTEM IN MANUAL CONTROL MODE WITH THE ADDITION OF THE PATIENT PROBE**WARNING**

- A physician's order is required for setting blanket temperature and use of equipment. At least every 20 minutes, or as directed by physician, check patient's temperature and skin integrity of areas in contact with blanket; also, check the BLANKETROL III's water temperature. Pediatric patients, temperature-sensitive patients with vascular disease, surgical patients, diabetics and patients with Raynaud's Disease are at a greater risk for developing tissue injuries, and this should be considered when selecting the temperature, duration of therapy and frequency of skin checks. **Notify the physician promptly of any change in patient status in order to avoid serious injury or death.**
- The method of temperature control provided by all hyper-hypothermia units presents the danger of heating or cooling body tissues, particularly the skin, to a point where they are injured, i.e., burns or frostbite, respectively. The clinician is responsible for determining the appropriateness of the temperature limits in dependency to time. **Exceeding 40°C water temperature for extended periods can cause tissue damage and burns. Clinical judgment should be used to determine the safe maximum contact periods based on patient age, clinical condition, and current medications. Depending on the extent and severity of a burn, very serious and even fatal complications may arise.**
- Due to static electricity, a 400 Series Probe may not be connected to the BLANKETROL III unit without first discharging one's body to the frame of the BLANKETROL III unit or another grounded object. **Failure to do so may result in damage from electrostatic discharge (ESD).** All staff that may touch the 400 Series Probe must be familiar with this warning and basic static electricity or electrostatic discharge (ESD) training.
- Basic static electricity or ESD training should include an introduction to the physics of electrostatic charge, the voltage levels that can occur in normal practice and the damage that can be done to electronic components if equipment is touched by an operator who is electrostatically charged. Further, an explanation should be given of methods to prevent build-up of electrostatic charge, and how and why to discharge one's body to the BLANKETROL III unit or another grounded object. **Failure to do so may result in damage from electrostatic discharge (ESD).**

When the BLANKETROL III System is set to operate in Manual Control Mode, the patient probe can be connected to the unit to monitor the patient's temperature without affecting the operation. The system continues to operate based upon the temperature of the water in the BLANKETROL III equipment relative to the desired Blanket/Water temperature.

After arranging the equipment as described in Section (3-2.), proceed as follows:

- A. Check the placement of the 400 Series probe in or on the patient.
- B. Connect the 400 Series probe to the 1/4 inch receptacle on the right side of the unit.
- C. Follow Steps (A - I) as described in Section (3-4.). In addition to the Blanket/Water display showing actual water temperature, the Patient display shows the actual patient temperature.

The BLANKETROL III System is now operating in *MANUAL CONTROL MODE* while monitoring the patient's temperature. However, you must also monitor the patient's temperature. (Review the suggestions for patient care described in Section (2-5.).)

If at any time the Status Display shows a message other than the messages described in Manual Control MODE procedures, make the changes indicated by the display and/or consult the list of

display messages in Section (3-10.). If at any time the unit sounds an alarm and the Status Display flashes a message, make the changes as indicated.

To turn off the unit or discontinue hyper-hypothermia treatment, proceed as described in Section (3-9.).

NOTE: IN ORDER TO CHANGE FROM AUTOMATIC CONTROL MODE TO ANOTHER CONTROL MODE, FIRST PRESS THE “TEMP SET” BUTTON, AND THEN SELECT THE OPERATING MODE OF CHOICE.

In order to change from *MANUAL CONTROL MODE* to *MONITOR ONLY MODE*, simply press the Monitor Only button.

3-6. OPERATING THE BLANKETROL III UNIT IN GRADIENT 10C SMART MODE

WARNING

- A physician's order is required for setting blanket temperature and use of equipment. At least every 20 minutes, or as directed by physician, check patient's temperature and skin integrity of areas in contact with blanket; also, check the BLANKETROL III's water temperature. Pediatric patients, temperature-sensitive patients with vascular disease, surgical patients, diabetics and patients with Raynaud's Disease are at a greater risk for developing tissue injuries, and this should be considered when selecting the temperature, duration of therapy and frequency of skin checks. **Notify the physician promptly of any change in patient status in order to avoid serious injury or death.**
- The method of temperature control provided by all hyper-hypothermia units presents the danger of heating or cooling body tissues, particularly the skin, to a point where they are injured, i.e., burns or frostbite, respectively. The clinician is responsible for determining the appropriateness of the temperature limits in dependency to time. **Exceeding 40°C water temperature for extended periods can cause tissue damage and burns. Clinical judgment should be used to determine the safe maximum contact periods based on patient age, clinical condition, and current medications. Depending on the extent and severity of a burn, very serious and even fatal complications may arise.**
- Due to static electricity, a 400 Series Probe may not be connected to the BLANKETROL III unit without first discharging one's body to the frame of the BLANKETROL III unit or another grounded object. **Failure to do so may result in damage from electrostatic discharge (ESD).** All staff that may touch the 400 Series Probe must be familiar with this warning and basic static electricity or electrostatic discharge (ESD) training.
- Basic static electricity or ESD training should include an introduction to the physics of electrostatic charge, the voltage levels that can occur in normal practice and the damage that can be done to electronic components if equipment is touched by an operator who is electrostatically charged. Further, an explanation should be given of methods to prevent build-up of electrostatic charge, and how and why to discharge one's body to the BLANKETROL III unit or another grounded object. **Failure to do so may result in damage from electrostatic discharge (ESD).**

CAUTION

- If device is set to operate in any Automatic mode, the device will shut down and activate the CHECK PROBE alarm if the patient temperature falls below 30.0°C (86°F). Patient temperature must rise above 30.0°C (86°F) before restarting the device in Automatic mode. The device can be operated in Manual Control mode in order to warm the patient above 30.0°C (86°F). Potential for interruption of therapy.
- Do not use GRADIENT VARIABLE MODE OR GRADIENT 10C MODE without SMART MODE. Unintended therapy could occur.

The BLANKETROL III System can be set to gradually change a patient's temperature by maintaining the water in the BLANKETROL III equipment at a maximum temperature 10°C (18°F) different from the patient's body temperature and then increasing the gradient offset (temperature difference) between the patient's temperature and the water temperature by 5°C (9°F) every 30 minutes until the patient's temperature reaches Set Point.

After arranging the equipment as described in Section (3-2.), proceed as follows:

- A. Check the placement of the 400 Series probe in or on the patient.
- B. Connect the probe to the 1/4 inch receptacle on the right side of the unit.
- C. Press the power switch to "I" position.
 1. The switch illuminates green.
 2. The microprocessor board goes through self-test.
 3. The Status Display flashes CHECK SETPT.
- D. Consult the physician's orders to determine the desired patient Set Point temperature. As a safety precaution, the desired patient Set Point can only be set between 30°C - 40°C (86°F - 104°F) to operate in *GRADIENT 10C SMART MODE*.
- E. Use the C/F button to choose the desired temperature scale (English membrane only).
- F. Press the TEMP SET button.
 1. The microprocessor board beeps.
 2. The LED in the corner of the button illuminates.
 3. The Status Display shows a temperature Set Point.
- G. Press the Up arrow or Down arrow to change the Set Point temperature on the Status Display to the desired patient temperature. The display can only be set between 30°C - 40°C (86°F - 104°F).
 1. The microprocessor board beeps.
 2. The Set Point temperature in the Status Display changes.
- H. Press the GRADIENT 10C button.
 1. The microprocessor board beeps.
 2. The LED in the corner of the button illuminates.
 3. The PATIENT display shows the patient's actual temperature.
 4. The WATER display shows the actual temperature of the water in the BLANKETROL III equipment.
 5. The Status Display shows:

```
* XXXXXX PATIENT
      AUTO      SETPT 37.0 C
```

 Or Status Display shows:

```
PATIENT @SETPT
      AUTO      SETPT 37.0 C
```

 * ("XXXXXX" represents "HEATING" or "COOLING".)

The above depends upon the relationship of the patient temperature to the Set Point temperature. Note that the Set Point may be displayed in Fahrenheit.

6. The pump is activated. The heater or compressor may also be activated.

7. The water flow indicator on the right-side panel begins to move.
8. The water moves from the unit to the blanket and returns to the unit.
- I. Press the SMART key.
 1. The microprocessor board beeps.
 2. The LED on the SMART button illuminates.
- J. Check the Water Flow indicator to confirm that the water is circulating.
- K. Touch the hyper-hypothermia blanket to confirm that the blanket is heating/cooling.
- L. To make any changes in the control settings, press the TEMP SET button and begin again.

The BLANKETROL III System is now operating in *GRADIENT 10C SMART MODE*. You should continue to monitor the system and the patient. (Review the suggestions for patient care described in Section (2-5.)).

If at any time the Status Display shows a message other than the messages described in *GRADIENT 10C SMART MODE* procedures, make the changes indicated by the display and/or consult the list of display messages in Section (3-10.). If at any time the unit sounds an alarm and the Status Display flashes a message, make the changes indicated.

To turn off the unit or discontinue hyper-hypothermia treatment, proceed as described in Section (3-9.).

NOTE: IN ORDER TO CHANGE FROM GRADIENT 10C SMART MODE TO ANOTHER CONTROL MODE, FIRST PRESS THE "TEMP SET" BUTTON, AND THEN SELECT THE OPERATING MODE OF CHOICE.

In order to change from *GRADIENT 10C SMART MODE* to *MONITOR ONLY MODE*, simply press the MONITOR ONLY button.

3-7. OPERATING THE BLANKETROL III SYSTEM IN *GRADIENT VARIABLE SMART MODE*

WARNING

- A physician's order is required for setting blanket temperature and use of equipment. At least every 20 minutes, or as directed by physician, check patient's temperature and skin integrity of areas in contact with blanket; also, check the BLANKETROL III's water temperature. Pediatric patients, temperature-sensitive patients with vascular disease, surgical patients, diabetics and patients with Raynaud's Disease are at a greater risk for developing tissue injuries, and this should be considered when selecting the temperature, duration of therapy and frequency of skin checks. **Notify the physician promptly of any change in patient status in order to avoid serious injury or death.**
- The method of temperature control provided by all hyper-hypothermia units presents the danger of heating or cooling body tissues, particularly the skin, to a point where they are injured, i.e., burns or frostbite, respectively. The clinician is responsible for determining the appropriateness of the temperature limits in dependency to time. **Exceeding 40°C water temperature for extended periods can cause tissue damage and burns. Clinical judgment should be used to determine the safe maximum contact periods based on patient age, clinical condition, and current medications. Depending on the extent and severity of a burn, very serious and even fatal complications may arise.**

WARNING

- Due to static electricity, a 400 Series Probe may not be connected to the BLANKETROL III unit without first discharging one's body to the frame of the BLANKETROL III unit or another grounded object. **Failure to do so may result in damage from electrostatic discharge (ESD).** All staff that may touch the 400 Series Probe must be familiar with this warning and basic static electricity or electrostatic discharge (ESD) training.
- Basic static electricity or ESD training should include an introduction to the physics of electrostatic charge, the voltage levels that can occur in normal practice and the damage that can be done to electronic components if equipment is touched by an operator who is electrostatically charged. Further, an explanation should be given of methods to prevent build-up of electrostatic charge, and how and why to discharge one's body to the BLANKETROL III unit or another grounded object. **Failure to do so may result in damage from electrostatic discharge (ESD).**

CAUTION

- If device is set to operate in any Automatic mode, the device will shut down and activate the CHECK PROBE alarm if the patient temperature falls below 30.0°C (86°F). Patient temperature must rise above 30.0°C (86°F) before restarting the device in Automatic mode. The device can be operated in Manual Control mode in order to warm the patient above 30.0°C (86°F). Potential for interruption of therapy.
- Do not use GRADIENT VARIABLE MODE OR GRADIENT 10C MODE without SMART MODE. Unintended therapy could occur.

The BLANKETROL III System can be set to gradually change the patient's temperature according to *specific patient's needs* by maintaining the water in the BLANKETROL III equipment at a specified temperature from the patient's body temperature (as chosen by the operator). The system then increases this temperature difference by 5°C (9°F) every 30 minutes until the patient's temperature reaches Set Point.

After arranging the equipment as described in Section (3-2.), proceed as follows:

- A. Check the placement of the 400 Series probe in or on the patient.
- B. Connect the probe to the 1/4 inch receptacle on the right side of the unit.
- C. Press the power switch to the "I" position.
 1. The switch illuminates green.
 2. The microprocessor board goes through self-test.
 3. The Status Display flashes CHECK SETPT.
- D. Consult the physician's orders to determine the desired patient Set Point temperature. As a safety precaution, the desired patient Set Point can only be set between 30°C - 40°C (86°F - 104°F) to operate in *GRADIENT VARIABLE SMART MODE*.
- E. Use the C/F button to choose the desired temperature scale (English membrane only).
- F. Press the TEMP SET button.
 1. The microprocessor board beeps.
 2. The LED in the corner of the switch illuminates.
 3. The Status Display shows a temperature Set Point.
- G. Press the Up arrow or Down arrow to change the Set Point temperature on the Status Display to the desired patient temperature. The display can only be set between 30°C - 40°C (86°F - 104°F).

1. The microprocessor board beeps.
 2. The Set Point temperature in the Status Display changes.
- H. Press the GRADIENT VARIABLE button.
1. The microprocessor board beeps.
 2. The LED in the corner of the button illuminates.
 3. The Status Display shows a gradient variable.
- I. Press the Up arrow or Down arrow to change the gradient variable offset to the desired value.
1. The microprocessor board beeps.
 2. The Set Point temperature in the Status Display changes.
- J. Press the GRADIENT VARIABLE button.
1. The microprocessor board beeps.
 2. The LED in the corner of the switch illuminates.
 3. The PATIENT display shows the patient's actual temperature.
 4. The WATER display shows the actual temperature of the water in the BLANKETROL III equipment.
 5. The Status Display shows:
 * XXXXXX PATIENT
 AUTO SETPT 37.0 C
 Or Status Display shows:
 PATIENT @SETPT
 AUTO SETPT 37.0 C
 * ("XXXXXX" represents "HEATING" or "COOLING".)

The above depends upon the relationship of the patient temperature to the Set Point temperature. Note that the Set Point may be displayed in Fahrenheit.

6. The pump is activated. The heater or compressor may also be activated.
 7. The Water Flow indicator on the right side panel begins to move.
 8. The water moves from the unit to the blanket and returns to the unit.
- K. Press the SMART key.
1. The microprocessor board beeps.
 2. The LED on the SMART button illuminates.
- L. Check the water flow indicator to confirm that the water is circulating.
- M. Touch the hyper-hypothermia blanket to confirm that the blanket is heating/cooling.
- N. To make any changes in the control settings, press the TEMP SET button and begin again.

The BLANKETROL III System is now operating in GRADIENT VARIABLE SMART mode. You should continue to monitor the system and the patient. (Review the suggestions for patient care described in Section (2-5).)

If at any time the Status Display shows a message other than the messages described in GRADIENT VARIABLE SMART mode procedures, make the changes indicated by the display and/or consult the list of display messages in Section (3-10.). If at any time the unit sounds an alarm and the Status Display flashes a message, make the changes indicated.

To turn off the unit or discontinue hyper-hypothermia treatment, proceed as described in Section (3-9.).

NOTE: IN ORDER TO CHANGE FROM GRADIENT VARIABLE SMART MODE TO ANOTHER CONTROL MODE, FIRST PRESS THE "TEMP SET" BUTTON, AND THEN SELECT THE OPERATING MODE OF CHOICE.

In order to change from *GRADIENT VARIABLE SMART MODE* to *MONITOR ONLY MODE*, simply press the MONITOR ONLY button.

3-8. OPERATING THE BLANKETROL III SYSTEM IN *MONITOR ONLY MODE*

WARNING

- Due to static electricity, a 400 Series Probe may not be connected to the BLANKETROL III unit without first discharging one's body to the frame of the BLANKETROL III unit or another grounded object. **Failure to do so may result in damage from electrostatic discharge (ESD).** All staff that may touch the 400 Series Probe must be familiar with this warning and basic static electricity or electrostatic discharge (ESD) training.
- Basic static electricity or ESD training should include an introduction to the physics of electrostatic charge, the voltage levels that can occur in normal practice and the damage that can be done to electronic components if equipment is touched by an operator who is electrostatically charged. Further, an explanation should be given of methods to prevent build-up of electrostatic charge, and how and why to discharge one's body to the BLANKETROL III unit or another grounded object. **Failure to do so may result in damage from electrostatic discharge (ESD).**

The BLANKETROL III System can be set so it displays the patient's temperature but does not heat, cool, or circulate the water. In this operating mode the patient may or may not already be positioned on a hyper-hypothermia blanket, but the unit and the 400 Series probe must be arranged as described in Section (3-2.).

After arranging the equipment, proceed as follows:

- A. Check the placement of the 400 Series probe in or on the patient.
- B. Connect the probe to the 1/4 inch receptacle on the right side of the unit.
- C. Press the power switch to "I" position.
 1. The switch illuminates green.
 2. The microprocessor board goes through self-test.
 3. The Status Display flashes CHECK SETPT.
- D. Press the MONITOR ONLY button.
 1. The microprocessor board beeps.
 2. The LED in the corner of the button illuminates.
 3. The Patient display shows the patient's temperature.
 4. The Status Display indicates MONITOR ONLY and the selected temperature scale.
- E. To make any changes in the control settings, press the TEMP SET button and begin again.

The BLANKETROL III System is now operating in Monitor Only Mode.

If at any time the Status Display shows a message other than the messages described in Monitor Only Mode procedures, make the changes indicated by the display and/or consult the list of display messages in Section (3-10.). If at any time the unit sounds an alarm and the Status Display flashes a message, make the changes indicated. To turn off the unit or discontinue hyper-hypothermia treatment, proceed as described in Section (3-9.).

NOTE: IN ORDER TO CHANGE FROM MONITOR ONLY MODE TO ANOTHER OPERATING MODE, FIRST PRESS THE “TEMP SET” BUTTON, AND THEN SELECT THE OPERATING MODE OF CHOICE.

3-9. CONCLUDING HYPER-HYPOTHERMIA TREATMENT

Discontinue therapy upon the order of the physician. Patient's temperature can drift up or down .5°C (1°F) after therapy has been discontinued. The drift may be greater if the patient has been shivering and treatment is abruptly discontinued. The operator should continue to monitor the patient's temperature. To do so, the operator may choose to operate the system in Monitor Only Mode as described in Section (3-8.).

To change the mode of operation or to stop the unit, the operator must press the TEMP SET button or turn the power switch to the “O” position. The operator can go directly to Monitor Only Mode from any of the control modes by pressing the MONITOR ONLY button.

When the hyper-hypothermia therapy is concluded, and the unit is turned off:

- A. Permit the blanket(s) and hose to remain connected to the unit for about ten minutes. This allows some of the water to drain back into the unit.
- B. Remove the probe from the patient and 1/4 inch receptacle.
- C. Disconnect the power cord from the power source, loosely coil it and attach it to the back panel using the nylon strap.
- D. Disconnect the connecting hose from the unit and store in the front storage drawer.
- E. Remove the blanket(s).
- F. For reusable PLASTIPAD blankets, loosely coil the hose lengthwise in the center of the blanket. Fold the blanket lengthwise into the center, 1/3 from the left side and 1/3 from the right side. Maintenance of the blanket is described in Section (4-6.).

For Single-Patient Use blankets, dispose of the blanket per hospital/institution policy/protocol.

3-10. STATUS DISPLAY MESSAGES

The Status Display located in the center of the BLANKETROL III unit membrane control panel reports the operating status of the unit or indicates changes the operator must make. The Status Display can show different messages to guide the operator. The following list defines each message and describes the changes, if any, the operator must make. Note that in the list below, the symbol “x” is used to indicate a numerical digit that can change based on measurements or operator actions and “Y” is used when C or F would be displayed depending on the temperature scale in use.

- A. During normal operation in *MANUAL CONTROL MODE*, the Status Display shows the following messages:

Status Display Message	Function
MANUAL	This message is displayed on the left side of the bottom line and indicates that the BLANKETROL III is operating in <i>MANUAL CONTROL MODE</i> .
SETPT xxx.xY *	* (“xxx.x” represents Temperature and “Y” represents Centigrade or Fahrenheit.) This message is displayed on the right side of the bottom line and indicates the desired/current Set Point temperature for the water in the device with appropriate temperature scale.
HEATING WATER	This message is displayed on the top line when the BLANKETROL III is heating the circulating water.
COOLING WATER	This message is displayed on the top line when the BLANKETROL III is cooling the circulating water.

WATER @SETPT	This message is displayed on the top line when the water temperature has reached the water temperature Set Point.
--------------	---

- B. During normal operation in the three automatic modes, *AUTOMATIC CONTROL MODE*, *GRADIENT 10C SMART MODE*, and *GRADIENT VARIABLE SMART MODE*, the Status Display shows the following messages:

Status Display Message	Function
AUTO	This message is displayed on the left side of the bottom line and indicates that the BLANKETROL III is operating in one of the three automatic modes.
SETPT xxx.xY *	* ("xxx.x" represents Temperature and "Y" represents Centigrade or Fahrenheit.) This message is displayed on the right side of the bottom line in the three automatic modes and indicates the desired/current Set Point temperature for the patient with appropriate temperature scale.
HEATING PATIENT	This message is displayed on the top line when the BLANKETROL III is heating the patient.
COOLING PATIENT	This message is displayed on the top line when the BLANKETROL III is cooling the patient.
PATIENT @SETPT	This message is displayed on the top line when the patient's temperature has reached the Set Point temperature.

- C. During normal operation in *MONITOR ONLY MODE* the Status Display shows the following messages:

Status Display Message	Function
MONITOR ONLY CELSIUS	This message is displayed when the temperature scale is set to Celsius in <i>MONITOR ONLY MODE</i> .
MONITOR ONLY FAHRENHEIT	This message is displayed when the temperature scale is set to Fahrenheit in <i>MONITOR ONLY MODE</i> .

- D. The following messages are warnings and indications shown in the Status Display:

Indication/Warning Message	Function
CHECK SETPT	<p>This message occurs for the following three possible reasons, followed by their remedial actions:</p> <ol style="list-style-type: none"> 1. During start up, when the operator turns the unit ON: <ol style="list-style-type: none"> a. Proceed by pressing the TEMP SET button to enter the Set Point temperature. 2. During start up, when the operator attempts to begin one of the three Automatic Control modes with a Patient Set Point temperature selected outside the range of 30°C - 40°C (86°F - 104°F). The unit will not permit the operator to proceed to the Automatic Control modes until the Patient Set Point temperature setting is corrected: <ol style="list-style-type: none"> a. Proceed by pressing the TEMP SET button and change the SET POINT temperature to bring it within the allowable range. 3. During operation, a "low water" condition could cause CHECK SETPT to indicate: <ol style="list-style-type: none"> a. Check the water level in the reservoir and fill the unit with water, as necessary. <p>Note: If the CHECK SETPT display flashes for five minutes, the alarm will sound until the operator proceeds to the next step. This alarm will also notify the operator if there has been an interruption in power.</p>
SET TEMPERATURE SETPT xxx.xY *	* ("xxx.x" represents Temperature and "Y" represents Centigrade or Fahrenheit.) This message occurs when the "TEMP SET" button is pressed. The Status Display can now be changed by pressing the Up or Down arrow or verify the preset temperature of 37°C (98.6°F) on power-up.

GRADIENT VARIABLE OFFSET xxY *	* (“xx” represents Temperature and “Y” represents Centigrade or Fahrenheit.) This is displayed after the first press of the GRADIENT VARIABLE button, when the user is setting the BLANKETROL III in <i>GRADIENT VARIABLE MODE</i> . When this display is shown, the user can adjust the gradient variable offset.
HIGH LIMIT REMOVE FROM SERVICE	This message occurs when the high limit is triggered because the water in the BLANKETROL III equipment has reached the high temperature of $44.0^{\circ}\text{C} \pm 2^{\circ}\text{C}$ ($111.2^{\circ}\text{F} \pm 3.6^{\circ}\text{F}$). While this message is displayed, the trouble alarm will sound, and the heater and pump will turn off. The alarm silence key cannot silence this alarm. This message will continue to display, and the trouble alarm will continue to sound until the unit is turned off using the ON/OFF switch or the power cord is disconnected from the power source. If the unit is unplugged before turning the ON/OFF switch, the power fail alarm will activate, and the power fail LED will light. If the unit is turned back on, this message will reappear, and the trouble alarm will sound. The unit cannot be used again until it is serviced. The seven-segment displays (“WATER” and “PATIENT”) will both be blank during this condition. Contact GENTHERM Technical Service.
HIGH LIMIT REMOVE FROM SERVICE	This message occurs when the software fails and the water in the BLANKETROL III equipment has reached the high temperature limit of $44.0^{\circ}\text{C} \pm 2^{\circ}\text{C}$ ($111.2^{\circ}\text{F} \pm 3.6^{\circ}\text{F}$), activating the independent safety. While this message is displayed, the trouble alarm will sound, and the heater and pump will turn off. The alarm silence key cannot silence this alarm. This message will continue to display, and the trouble alarm will continue to sound until the unit is turned off using the ON/OFF switch or the power cord is disconnected from the power source. If the unit is unplugged before turning the ON/OFF switch, the power fail alarm will activate, and the power fail LED will light. If the unit is turned back on, this message will reappear, and the trouble alarm will sound. The unit cannot be used again until it is serviced. The seven-segment displays (“WATER” and “PATIENT”) will both be blank during this condition. Contact GENTHERM Technical Service.
SNAP DISC REMOVE FROM SERVICE	<p>This message occurs when the thermostatic snap disc has opened or is disconnected, or when the reservoir temperature has exceeded $46^{\circ}\text{C} \pm 2^{\circ}\text{C}$ ($114.8 \pm 3.6^{\circ}\text{F}$) causing the thermostatic disc to shut off heating. While this message is displayed, EE02** will display in the “PATIENT” temperature display, the trouble alarm will sound, and the heater, compressor and pump will turn off. The alarm silence key cannot silence this alarm. This message will continue to display, and the trouble alarm will continue to sound until the unit is turned off using the ON/OFF switch or the power cord is disconnected from the power source. If the unit is unplugged before turning the ON/OFF switch, the power fail alarm will activate, and the power fail LED will light. If the unit is turned back on, only “SNAP DISC” “REMOVE FROM SERVICE” will reappear and the trouble alarm will sound, even if disc has reset. The unit cannot be used again until it is serviced. Contact GENTHERM Technical Service.</p> <p>**EE02 appears when the thermostatic snap disc has opened or is disconnected</p>
LOW LIMIT REMOVE FROM SERVICE	This message occurs when the low limit is triggered because the water in the BLANKETROL III equipment has reached the low temperature limit of $2.0^{\circ}\text{C} \pm 2^{\circ}\text{C}$ ($35.6^{\circ}\text{F} \pm 3.6^{\circ}\text{F}$). While this message is displayed, the trouble alarm will sound, and the compressor and pump will turn off. The alarm silence key cannot silence this alarm. This message will continue to display, and the trouble alarm will continue to sound until the unit is turned off using the ON/OFF switch or the power cord is disconnected from the power source. If the unit is unplugged before turning the ON/OFF switch, the power fail alarm will activate, and the power fail LED will light. If the unit is turned back on, this message will reappear, and the trouble alarm will sound. The unit cannot be used again until it is serviced. The seven-segment displays (“WATER” and “PATIENT”) will both be blank during this condition. Contact GENTHERM Technical Service.

<p>LOW LIMIT REMOVE FROM SERVICE</p>	<p>This message occurs when the software fails and the water in the BLANKETROL III equipment has reached the low temperature limit of $2.0^{\circ}\text{C} \pm 2^{\circ}\text{C}$ ($35.6^{\circ}\text{F} \pm 3.6^{\circ}\text{F}$), activating the independent safety. While this message is displayed, the trouble alarm will sound, and the compressor and pump will turn off. The alarm silence key cannot silence this alarm. This message will continue to display, and the trouble alarm will continue to sound until the unit is turned off using the ON/OFF switch or the power cord is disconnected from the power source. If the unit is unplugged before turning the ON/OFF switch, the power fail alarm will activate, and the power fail LED will light. If the unit is turned back on, this message will reappear, and the trouble alarm will sound. The unit cannot be used again until it is serviced. The seven-segment displays ("WATER" and "PATIENT") will both be blank during this condition. Contact GENTHERM Technical Service.</p>
<p>EE01 REMOVE FROM SERVICE</p>	<p>This message occurs when EE01 appears in the PATIENT temperature display. Both messages appear when the backup processor does not agree with the primary processor. While both messages are displayed, the trouble alarm will sound, and the heater, compressor and pump will turn off. The alarm silence key cannot silence this alarm. Both messages will continue to display, and the trouble alarm will continue to sound until the unit is turned off using the ON/OFF switch or the power cord is disconnected from the power source. If the unit is unplugged before turning the ON/OFF switch, the power fail alarm will activate, and the power fail LED will light. If the unit is turned back on, only "EE01" "REMOVE FROM SERVICE" will reappear in the Status Display and the trouble alarm will sound. The unit cannot be used again until it is serviced. Contact GENTHERM Technical Service.</p>
<p>SENSOR FAULT REMOVE FROM SERVICE</p>	<p>This message will be displayed if the water temperature sensor is open or shorted. The trouble alarm will sound, and this message will continue to display until the power cord is disconnected from the power source. The unit cannot be used again until it is serviced. While this message is displayed, the trouble alarm will sound, and the heat, compressor and pump will be off. The alarm silence key cannot silence this alarm. The seven-segment displays (WATER and PATIENT) will both be blank during this condition. This message will also be displayed if the WATER temperature is out of the range, $0^{\circ}\text{C} - 52.0^{\circ}\text{C}$ ($32^{\circ}\text{F} - 125.6^{\circ}\text{F}$), of the available temperature readout. Contact GENTHERM Technical Service</p>

CHECK PROBE	<p>This message is displayed to alert the operator when the probe needs to be checked. For instance:</p> <ol style="list-style-type: none"> 1. If the probe is operating outside of the normal operating range of 30.0°C – 43.5°C (86°F to 110.3°F) during any automatic mode, this message will be displayed. 2. If the probe is not connected to the 1/4 inch receptacle prior to pressing any of the automatic modes button. 3. If the probe is dislodged from the patient. 4. If the PATIENT temperature falls below 30°C (86°F). 5. If the PATIENT temperature is greater than 43.5°C (110.3°F). 6. If the probe is defective or open. 7. If other than a 400 Series probe was connected to the 1/4 inch receptacle. <p>As this message is displayed, the trouble alarm sounds and the unit shuts down. The operator can silence the alarm by pressing the SILENCE ALARM button. After silencing the alarm and checking the probe, the operator must press the TEMP SET button to proceed; otherwise STATUS will continue to display CHECK PROBE. The operator has 5 minutes to fix the probe. If after that time the condition has not been cleared, the system will trouble alarm again, even though the SILENCE ALARM button has been previously pressed.</p> <p>In <i>MONITOR ONLY MODE</i>, CHECK PROBE is displayed if:</p> <ol style="list-style-type: none"> 1. The temperature goes out of the range 10.0°C – 50.0°C (50°F – 122.0°F). <p>The trouble alarm sounds and cannot be silenced. The patient display is blank. If the temperature comes back into range, the unit should resume operation in <i>MONITOR ONLY MODE</i>.</p> <p>In <i>MANUAL CONTROL MODE</i>, a probe out of range should result in the PATIENT display going blank, but the unit continuing operation with no error message. If the temperature comes back into range, the PATIENT display should come back on.</p>
BAD PROBE	<p>While in any of the three automatic modes, if the patient probe indicates only a direct short in the probe circuit this message occurs. As this message is displayed, the trouble alarm sounds and the unit shuts down. This alarm can be silenced using the SILENCE ALARM button. The operator then has 5 minutes to fix the probe. If after that time the condition has not been fixed, the system will trouble alarm again, even though the SILENCE ALARM button has been previously pressed. During this condition, the seven-segment displays will both be blank.</p> <p>While operating in <i>MANUAL CONTROL mode</i>, if a bad patient probe develops, the heating/cooling system remains on, but the seven-segment PATIENT display blanks.</p> <p>While operating in the <i>MONITOR ONLY mode</i>, if a bad patient probe develops, the BAD PROBE message displays, the audible alarm sounds and the "PATIENT" temperature display blanks. The audible alarm can be silenced using the SILENCE ALARM button. The operator then has 5 minutes to fix the probe. If after that time the condition has not been fixed, the system will trouble alarm again, even though the SILENCE ALARM button has been previously pressed. Connecting a working probe in range should clear the error message and return the unit to normal operation in <i>MONITOR ONLY mode</i>.</p>

LOW WATER	This message occurs when the float switch senses that the water in the reservoir is below a preset level or the float switch is defective. The trouble alarm sounds, the seven-segment displays will be blank, the low water symbol LED will flash, and the heater, compressor and pump will turn off. The LCD display shall display the scrolling message "LOW WATER" for 5 seconds followed by "REPLENISH RESERVOIR" for 5 seconds followed by "PRESS Δ TO CONTINUE" and scroll between them until the increment key is pressed. The operator can silence this alarm using the "SILENCE ALARM" button. The condition can also be satisfied if the operator adds water to the reservoir and it reaches the proper level and the increment key has been pressed to clear the scrolling "LOW WATER" followed by "PRESS Δ TO CONTINUE" message. Once the LOW WATER condition is satisfied, the Status Display changes to show CHECK SETPT. The trouble alarm should still sound. In order to proceed, the operator must once again go through the operating mode button sequence. If the alarm is silenced, the operator has 5 minutes to add water. If after that time the condition has not been cleared, the system will trouble alarm again even though the SILENCE ALARM button has been previously pressed.
LOW FLOW	This message is displayed when the flow out of the unit to a blanket is reduced below 6 ± 3 GPH after an acceptable flow has been previously detected. Along with this message, a trouble alarm will sound. The operator can silence this alarm using the SILENCE ALARM button. The operator has 5 minutes to fix the condition. If after that time the condition has not been cleared, the system will trouble alarm again even though the SILENCE ALARM button has been previously pressed. The condition can also be satisfied if the flow increases above 6 ± 3 GPH.
CHECK FLOW SWITCH	This message will be displayed after the indicators are tested if the flow switch is closed upon initial power up of the unit. This indication results from a stuck flow switch. The audible alarm shall sound continuously for 30 seconds. After 30 seconds, the message will clear, and the alarm will stop sounding. Pressing the SILENCE ALARM key while the alarm is sounding shall silence the alarm and clear the message. A unit with a bad flow switch is still operable; however, a LOW FLOW alarm will not sound when flow through the blanket is blocked.
PM REQUIRED	This message will be displayed after 500 hours of operation past the last time the (500 hour) counter was reset. The message will only be displayed for 5 seconds at power-up. Note: Only qualified Medical Equipment Service Technicians, Certified Biomedical Electronics Technicians, or Certified Clinical Engineers can reset the 500-hour counter after preventative maintenance has been performed. To reset the PM REQUIRED alarm, simultaneously press the SILENCE ALARM, Decrement, and Increment buttons.
TOTAL HOURS	This message displays the total hours of operation. To display this message, simultaneously press the Increment and Decrement buttons.
HOURS UNTIL SERVICE	This message displays the total number of hours of operation until the next required PM. To display this message, simultaneously press SILENCE ALARM and TEMP SET buttons. Note: 1. Maintenance should be performed at least quarterly or when indicated by 500 hour PM notification, whichever occurs first. 2. Only qualified Medical Equipment Service Technicians, Certified Biomedical Electronics Technicians, or Certified Clinical Engineers can reset the Hours Until Service hour counter after preventative maintenance has been performed. To reset the HOURS UNTIL SERVICE hour counter back to 500, simultaneously press the SILENCE ALARM, Decrement, and Increment buttons.
UNDER TEST	This message is displayed while the unit is under test during preventative maintenance.

SECTION 4. GENERAL MAINTENANCE OF THE BLANKETROL III SYSTEM**4-1. INTRODUCTION**

This section describes the general requirements maintenance personnel should complete on a regular basis so that the BLANKETROL III System continues to operate within the manufacturers' allowable tolerances.

Maintenance and service activities will sometimes overlap. In general, maintenance refers to any activity that does not require a certified technician. Maintenance may be performed by healthcare personnel or by other trained persons. The following actions are considered maintenance:

1. Inspecting, cleaning, and disinfecting the exterior
2. Adding or replacing water
3. Replacing hoses
4. Cleaning hoses, blankets
5. Draining reservoirs

Service refers to any activity that requires a Medical Equipment Service Technician, Certified Biomedical Electronics Technician, or a Certified Clinical Engineer. The following actions are considered service:

1. Equipment or parts replacement
2. Repairs
3. System testing
4. Cleaning & disinfecting water reservoirs
5. Replacing hoses (air, water), cords, and other accessories

These requirements include changing and replenishing the water in the reservoir; replacing the water filter, the exterior of the unit, the front grill, the condenser, the thermistor probes, and the hyper-hypothermia blankets. Figure (4-1) provides a convenient checklist to record the maintenance history of the unit.

The description of each requirement includes the tools, the procedures, and the precautions necessary to complete the requirements. Maintenance, repair and/or service of BLANKETROL III by qualified maintenance/technical personnel **will not** void the warranty of the unit.

After maintenance has been performed, the qualified Medical Equipment Service Technician, Certified Biomedical Electronics Technician, or Certified Clinical Engineer should reset the PM Required/HOURS UNTIL SERVICE hour counter back to 500 by simultaneously pressing SILENCE ALARM, Decrement and Increment buttons.

WARNING

- **Before** returning the BLANKETROL III to patient use **after** repairs, the **FIRST TIME SET-UP/SYSTEM TEST ROUTINE** in Section 2 must **always** be performed. **Improper repair and inadequate maintenance can result in damage to the BLANKETROL III system and patient injury.**

The following procedures should be performed quarterly or when indicated by 500 hour PM notification, whichever occurs first.

- Draining/Replenishing the Reservoir
- Cleaning the Condenser and Grill
- Maintenance Checklist
- Replacing the Water Filter
- Cleaning Water System
- Cleaning Hyper-Hypothermia Blankets
- Cleaning the Exterior of the Unit

- Check Leakage Current
- Cleaning the Water Flow Indicator Assembly
- Test low and high temperature protection
- Check temperature accuracy

4-1.1. TEST EQUIPMENT REQUIRED

The following test equipment is required to perform the preventive maintenance/functional check-out procedures:

- GENTHERM's model TFRW 86171 Trimatic (Temperature Tester, Flow Meter, Resistance Tester)
 - Need Probe Extension Cable #TM-4A (Part # 39005)
 - Need Hose Assembly #TM-6 (Part # 91802)
- 400 Series Probes, calibrated Mercury Thermometer, or Thermocouple
- Leakage Current Tester
- Small slotted screwdriver
- Phillips screwdriver

FIGURE 4-1. BLANKETROL III MAINTENANCE CHECKLIST

REQUIRED PREVENTIVE MAINTENANCE CHECKLIST

(Quarterly or when indicated by 500 hour PM notification)

BLANKETROL III - Model 233

Hospital Control No. _____

Serial Number _____

Check When Completed

- 1. External cabinet in good condition. (No unusual dents or missing parts)
- 2. All labels properly affixed.
- 3. Quick disconnect fittings are tight, straight, and not leaking.
- 4. Power cord (no cuts or exposed wire) and plug (no bent or missing prongs).
- 5. Indicator lights are operative.
- 6. Drain and clean reservoir. See Section 4-2.
 - a. Check circulation through all three (3) male couplings with drain hose
- 7. Replace water filter. See Section 4-3.
- 8. Refill reservoir with sterile water or water that has been passed through a filter less than or equal to 0.22 microns. See Section 4-2.2.
- 9. Condition of blankets, hoses, and couplings (check for leaks).
- 10. Connecting hoses are tight and not leaking.
- 11. Leakage current check; all readings should be under 300 microamps (115V).
- Leakage current check; all readings should be under 500 microamps (230V).
- See Section 5-17.
- OFF Normal Polarity _____ ON Reverse Polarity (heat) _____
- OFF Reverse Polarity _____ ON Normal Polarity (cool) _____
- ON Normal Polarity (heat) _____ ON Reverse Polarity (cool) _____
- 12. Check flow rate and pressure. greater than .60 GPM _____
- 13. Check the (HC) high temp safety 44°C +/- 2°C Reference Section 4-8
- 14. Check the (HS) high limit safety 44°C +/- 2°C Reference Section 4-8
- 15. Check the snap disc safety 46.0°C +/- 2°C Reference Section 4-8
- 16. Check the (LC) low temp safety 2°C +/- 2°C Reference Section 4-7
- 17. Check the (LS) low limit safety 2°C +/- 2°C Reference Section 4-7

Signature of Inspector

Date of Inspection

4-2. MAINTENANCE OF THE WATER RESERVOIR

The dual compartment reservoir holds approximately 2 gallons (7.6 liters) of sterile water or water that has been passed through a filter less than or equal to 0.22 microns that remains in the unit between periods of use. Quarterly, the water reservoir should be drained and replenished. The drain hose, included in the packaging of the unit, is attached and the water is pumped out of the unit. When the LOW WATER alarm sounds, the remaining water is drained by gravity. Sterile water or water that has been passed through a filter less than or equal to 0.22 microns is then poured into the reservoir.

NOTE: DO NOT USE DE-IONIZED WATER OR ALCOHOL.

Quarterly, at a minimum, the FLUID CIRCUIT DISINFECTION/DRY STORAGE PROCEDURE, listed below, should be conducted.

Note: This interior reprocessing procedure was validated using Clorox Bleach Solution (8.25% v/v sodium hypochlorite).

Alternate Internal Cleaning Agent: Clorox Bleach Solution ARTG 405627

CAUTION	
<ul style="list-style-type: none"> For safe handling and use of chemicals follow manufacturer guidelines. 	
<ul style="list-style-type: none"> Users should not use cleaning or decontamination methods different from those recommended by GENTHERM without first checking with GENTHERM that the proposed methods will not damage the equipment. 	
<ul style="list-style-type: none"> Always drain the BLANKETROL III to a sanitary drain because bio-contaminants may be present in the unit's water supply. 	

Chemical Cleaning Circulation Chart

UNIT	MODE	TEMPERATURE	DURATION
BLANKETROL III	Heating	38°C	5 Minutes

**FLUID CIRCUIT DISINFECTION/DRY STORAGE PROCEDURE
for Circulating Water Units Utilizing Household Bleach**

The required tools/supplies:

Drain hose(s) and/or hose connector(s), household bleach, sterile water or water that has been passed through a filter less than or equal to 0.22 microns, and the appropriate AC electrical power

The following procedure disinfects the fluid circuit in these products.

PROCEDURE:

1. Drain the water from the reservoir as described in Section 4-2.1.
2. Turn unit **off ("O" position)**.
3. Fill the reservoir with the appropriate amount of household bleach per the below chart.

UNIT	BLEACH	WATER
BLANKETROL III	227 Milliliters	7.6 Liters

4. Fill the reservoir with warm sterile water or water that has been passed through a filter less than or equal to 0.22 microns.
5. Turn the unit on and circulate per the Chemical Cleaning Circulation (CCC) Chart (above).

Note: The duration indicated in the CCC chart is meant to begin when the circulating water reaches the temperature indicated in the CCC chart.

6. Drain the unit as instructed in Step #1.
7. Rinse the unit three (3) times as described in Steps 4-6. Be sure to omit the household bleach (sodium hypochlorite).
8. After the third rinse, drain the unit and fill the reservoir with sterile water or water that has been passed through a filter less than or equal to 0.22 microns and circulate.
9. Check the water with pH strips or other appropriate test method for detecting bleach. If bleach is detected, repeat Steps 4-6.
10. Continue to fill the water reservoir with sterile water or water that has been passed through a filter less than or equal to 0.22 microns.
11. If unit is being **placed in dry storage**, continue with procedure.
12. When all fluid has been removed from the unit, disconnect the drain hose(s) and wipe unit clean.
13. Unit is now ready for storage.
14. Document unit maintenance.

When you are ready to return unit to service, replenish the reservoir(s) with sterile water or water that has been passed through a filter less than or equal to 0.22 microns. Perform all the checks as described in the respective Manual.

**FLUID CIRCUIT DISINFECTION/DRY STORAGE PROCEDURE
for Circulating Water Units Utilizing CE Approved Gigasept FF (Product of Schulke & Mayr)
(Contact your local Cleaning Supplier)**

(Gigasept FF Is Not Available in the United States)

The following procedure disinfects the fluid circuit in these products. The required tools/supplies are appropriate drain hose(s) and/or hose connector(s), Gigasept FF, sterile water or water that has been passed through a filter less than or equal to 0.22 microns, and the appropriate AC electrical power

PROCEDURE:

1. Drain the water from the reservoir as described in Section 4-2.1.
2. Turn unit **off** ("**O**" position).
3. Fill the reservoir with the appropriate amount of Gigasept FF per the below chart.

UNIT	Gigasept FF	WATER	DURATION
BLANKETROL III	800 Milliliters	7.6 Liters	15 Minutes

4. Fill the reservoir with the appropriate amount of water per the above chart.
5. Turn the unit on and circulate in Heating Mode @ 38°C for 15 minutes.
Note: The 15 minutes should not begin until the water reaches 38°C.
6. Drain the unit as instructed in Step #1.
7. Rinse the unit with Sterile water or water that has been passed through a filter less than or equal to 0.22 microns three (3) times as described in Steps 4-6. **Be sure to omit Gigasept FF.**
8. After the third rinse, drain the unit and fill the reservoir with sterile water or water that has been passed through a filter less than or equal to 0.22 microns and circulate.
9. Check the water with PH strips or other appropriate test method for Gigasept FF detection. If Gigasept FF is detected, repeat Steps 4-6.
10. If unit is to be **returned to service**, replenish reservoir(s) with the appropriate volume of sterile water or water that has been passed through a filter less than or equal to 0.22 microns.
11. If unit is being **placed in dry storage**, continue with procedure.
12. When all fluid has been removed from the unit, disconnect the drain hose(s) and wipe unit clean.
13. Unit is now ready for storage.

14. Document unit maintenance.

FLUID CIRCUIT DISINFECTION/DRY STORAGE PROCEDURE
for Circulating Water Units Utilizing CE Approved Maranon H (Product of Ecolab)
(Contact your local Cleaning Supplier)
(Maranon H Is Not Available In the United States)

The following procedure disinfects the fluid circuit in these products. The required tools/supplies are appropriate drain hose(s) and/or hose connector(s), Maranon H, sterile water or water that has been passed through a filter less than or equal to 0.22 microns, and the appropriate AC electrical power

PROCEDURE:

1. Drain the water from the reservoir as described in Section 4-2.1.
2. Turn unit **off** (“O” position).
3. Fill the reservoir with the appropriate amount of Maranon H per the below chart.

UNIT	MARANON H	WATER
BLANKETROL III	227 Milliliters	7.6 Liters

4. Fill the reservoir with the appropriate amount of water per the above chart.
5. Turn the unit on and circulate per the Chemical Cleaning Circulation (CCC) Chart (above).
 Note: The duration indicated in the CCC chart is meant to begin when the circulating water reaches the temperature indicated in the CCC chart.
6. Drain the unit as instructed in Step #1.
7. Rinse the unit with sterile water or water that has been passed through a filter less than or equal to 0.22 microns three (3) times as described in Steps 4-6. **Be sure to omit the Maranon H.**
8. After the third rinse, drain the unit and fill the reservoir with sterile water or water that has been passed through a filter less than or equal to 0.22 microns and circulate.
9. Check the water with PH strips or other appropriate test method for Maranon H detection. If Maranon H is detected, repeat Steps 4-6.
10. If unit is to be **returned to service**, replenish reservoir(s) with the appropriate volume of sterile water or water that has been passed through a filter less than or equal to 0.22 microns.
11. If unit is being **placed in dry storage**, continue with procedure.
12. When all fluid has been removed from the unit, disconnect the drain hose(s) and wipe unit clean.
13. Unit is now ready for storage.
14. Document unit maintenance.

4-2.1. Draining the Reservoir

CAUTION

- Always drain the BLANKETROL III to a sanitary drain because **bio-contaminants** may be present in the unit’s water supply.

- A. Collect these items:
 1. An empty container to drain the water into that can hold at least 3 gallons (11.4 liters).
 2. The drain hose with a female quick-disconnect fitting usually found in the storage drawer of the unit.
 3. 2 gallons (7.6 liters) sterile water or water that has been passed through a filter less than or equal to 0.22 microns to replenish the reservoir.
- B. Insert the drain end of the hose into the 3 gallon (11.4 liters) container. Set the container on the floor so the hose drains downward.

- C. Attach the female coupling of the drain hose to any one of the male outlet couplings on the right side of the unit.
 - 1. Slide back the collar of the female coupling.
 - 2. Insert the female coupling over the male coupling.
 - 3. Release the collar so the coupling 'Snaps' into position.

WARNING

- **Do not by-pass ground lug (230V System). Electrical Hazards may result.**

- D. Plug the power cord into a properly grounded power outlet.
- E. Place the power switch to the "I" position.
- F. Press the TEMP SET button.
- G. Press the MANUAL CONTROL button.

The water is pumped into the container until there is approximately ½ gallon (1.9 liters) of water remaining to be drained. The Status Display flashes LOW WATER and the alarm sounds. The unit shuts down, but the water continues to drain into the container because of gravitational pull.

- H. Press the SILENCE ALARM button.
- I. Press the power switch to the "O" position.
- J. Disconnect the power cord from the power source.
- K. After all the water has drained from the unit, disconnect the drain hose, wipe, clean and store in a dry environment without disinfecting. (Refer to Section (7.) specifications for storage conditions)
- L. Discard the water drained from the unit.
- M. If any other maintenance/repair is to be completed, go to the appropriate section, e.g., replacing the water filter. If not, go to Section (4-2.2.) to replenish the reservoir.

4-2.2. Replenishing the Reservoir

- A. Check that the drain hose is disconnected.

CAUTION

- **Use Sterile water or water that has been passed through a filter less than or equal to 0.22 microns only. Do Not Use distilled water. Do Not Use De-ionized water. De-ionized water may cause corrosion to plumbing system components. Do Not Use Tap Water. Minerals and deposits can clog plumbing system components.**
- **Do not use alcohol. Alcohol may cause blanket deterioration.**
- **Do not overfill. Overfilling may result in overflow when the water in the blanket drains back into the system when the system is turned off.**

- B. Lift the water fill opening lid and gradually pour approximately 2 gallons (7.6 liters) of sterile water or water that has been passed through a filter less than or equal to 0.22 microns described in Section (4-2.) into the reservoir (DO NOT USE ALCOHOL, DISTILLED WATER, TAP WATER, OR DE-IONIZED WATER).
- C. Stop pouring when the water reaches the strainer visible at the bottom of the water fill opening.
- D. Proceed with normal operations; always check the water level before starting.

4-3. MAINTENANCE OF THE WATER FILTER

The BLANKETROL III circulating system includes a water filter designed to clear the line of any particulate matter as the water is pumped through the system. The water filter assembly is a plastic T-shaped fitting that intersects the hose from the water flow indicator to the flow switch. A stainless-steel wire-mesh screen is located inside the clear plastic cap of the water filter assembly.

The water filter should be replaced quarterly or more often if deemed necessary. To do so, the reservoir must first be drained, and the front storage drawer extended. The cap of the water filter assembly is unscrewed. Water filter is replaced, and the screw clamps are tightened.

CAUTION

- Always drain the BLANKETROL III to a sanitary drain because **bio-contaminants** may be present in the unit's water supply.
 - A. Obtain replacement water filter assembly.
 - B. Disconnect the unit from its power source and drain the reservoir as described in Section (4-2.1.).
 - C. Extend the front storage drawer as described in Section (5-2.5.).
 - D. Locate the T-shaped water filter assembly tucked under the water reservoir.
 - E. Disconnect the assembly by loosening the two screw clamps (one on each side of the water filter assembly).
 - F. Remove the T-shaped water filter assembly.
 - G. Insert the replacement water filter assembly so the cap and screen point down and the arrow on the top points to the left. Connect one end to the hose from the water flow indicator and the other end to the hose to the flow switch.
 - H. Tighten both screw clamps.
 - I. Refill the reservoir as described in Section (4-2.2).
 - J. Reposition the front storage drawer as described in Section (5-2.6.).

4-4. MAINTENANCE OF THE CONDENSER AND GRILL

Quarterly the grill and the fins of the condenser should be cleaned to remove any accumulated dust and lint. To clean the condenser and grill:

WARNING

- The repair, calibration, and servicing of the BLANKETROL III should be performed by qualified Medical Equipment Service Technicians, Certified Biomedical Electronics Technicians, or Certified Clinical Engineers familiar with good repair practices for servicing medical devices, and in accordance with instructions contained in this manual. **Improper repair can result in damage to the BLANKETROL III system and patient injury.**
- Always **unplug the unit** before accessing internal components during service. **Failure to unplug the unit could result in electric shock.**
 - A. Remove the grill.
 - B. Using a brush or a vacuum, dust both sides of the front panel grill.
 - C. Next, brush or vacuum the fins of the condenser. Be careful not to bend any of the fins.
 - D. Replace the grill.

4-5. MAINTENANCE OF THE BLANKETROL III EXTERIOR – CLEANING INSTRUCTIONS

The BLANKETROL III unit is constructed of powder coated steel with a plastic top that should be cleaned quarterly with water and mild detergent solution. For cleaning and disinfecting, always use conventional hospital-approved topical equipment cleaners and disinfectants that do not contain alcohol. Avoid alcohol and other strong, undiluted disinfectants. These may cause staining of the device's outer skin. Thoroughly wipe down device with a damp cloth to remove any residue from cleaning solutions.

Exterior Cleaning section:

- "This exterior cleaning procedure was validated using PDI Sani-Cloth® Bleach Germicidal Disposable Wipes."

Exterior Disinfection section:

- "This exterior disinfection procedure was validated using PDI Sani-Cloth® Bleach Germicidal Disposable Wipes."

Alternate: Medical Device cleaning/disinfecting bleach wipes with 0.63% Sodium Hypochlorite; ARTG 335509, 332716

4-6. MAINTENANCE OF THE HYPER-HYPOTHERMIA BLANKETS

This section describes the general maintenance and for the reusable and disposable blankets. General maintenance tasks include cleaning, draining, and storing the blankets.

4-6.1. Reusable Blanket

Gentherm reusable blankets are constructed from biocompatible polyurethane/urethane. Stains and debris can be wiped away with mild soap and water. For cleaning and disinfecting, always use conventional hospital-approved topical cleaners and disinfectants that do not contain alcohol. Avoid alcohol and other strong, undiluted disinfectants. These may cause staining of the device's outer skin. Thoroughly rinse product with clear water to remove any residue from cleaning solutions. DO NOT use gas sterilization or autoclaving for cleaning and disinfecting the blankets. To drain the water from the reusable blankets simply shut off power to the unit or shut off the operation of the manual or automatic mode and allow the water to drain from the blanket back into the BLANKETROL III unit.

To store PLASTIPAD blankets, loosely coil the hose lengthwise into the center of the blanket. Fold the blanket lengthwise into the center, 1/3 from the left side and 1/3 from the right side. Do not fold the blankets width-wise, as doing so will crimp the tubing.

Disposal of blankets are done in a means consistent with hospital/institution policy/protocol for patient contact items.

4-6.2. Disposable, Single-Patient Use Blankets

The reusable blanket maintenance procedures do not apply to the disposable, single-patient use blankets. Disposal of blankets are done in a means consistent with hospital/institution policy/protocol for patient contact items.

4-7. LOW LIMIT SAFETIES CHECK

WARNING

- The repair, calibration, and servicing of the BLANKETROL III should be performed by qualified Medical Equipment Service Technicians, Certified Biomedical Electronics Technicians, or Certified Clinical Engineers familiar with good repair practices for servicing medical devices, and in accordance with instructions contained in this manual. **Improper repair can result in damage to the BLANKETROL III system and patient injury.**
- Always **unplug the unit** before accessing internal components during service. **Failure to unplug the unit could result in electric shock.**

- A. Plug the BLANKETROL III into the appropriate power supply and turn its power switch to the "O" position to turn unit off.
- B. Remove the top of the unit, as described in Section (5-2.2.), and locate the test jumpers in the storage position marked JP5 on the processor board, which is on the left edge of the board.
- C. Place one of these jumpers on the test port (JP4 position) in the location marked LC.
- D. Turn the unit on and monitor the temperature on the water temperature display as the water is cooled.
- E. The unit should cool the water to $2.0^{\circ}\text{C} \pm 2.0^{\circ}\text{C}$ and shut off; status should indicate LOW LIMIT REMOVE FROM SERVICE.
- F. Turn the unit off and remove the test jumper.
- G. Allow the water temperature to rise above 4.0°C .
- H. Place a jumper on the test port in the location marked LS.
- I. Turn the unit on and monitor the temperature on the water temperature display as the water is cooled.
- J. The unit should cool the water to $2.0^{\circ}\text{C} \pm 2.0^{\circ}\text{C}$ and shut off; status should indicate LOW LIMIT REMOVE FROM SERVICE.
- K. Turn the unit off and remove the test jumper.
- L. Allow the water temperature to rise above 4.0°C .

4-8. HIGH LIMIT SAFETIES CHECK

WARNING

- The repair, calibration, and servicing of the BLANKETROL III should be performed by qualified Medical Equipment Service Technicians, Certified Biomedical Electronics Technicians, or Certified Clinical Engineers familiar with good repair practices for servicing medical devices, and in accordance with instructions contained in this manual. **Improper repair can result in damage to the BLANKETROL III system and patient injury.**
- Always **unplug the unit** before accessing internal components during service. **Failure to unplug the unit could result in electric shock.**

- A. Plug the BLANKETROL III into the appropriate power supply and turn its power switch to the "O" position to turn unit off.

- B. Remove the top of the unit, as described in Section (5-2.2.), and locate the test jumpers in the storage position marked JP5 on the microprocessor board, which is on the left edge of the board.
- C. Place a jumper on the test port (JP4 position) in the location marked HC.
- D. Turn the unit on and monitor the temperature on the water temperature display as the water is heated.
- E. The BLANKETROL III should heat the water to $44.0^{\circ}\text{C} \pm 2.0^{\circ}\text{C}$ and shut off; status should indicate HIGH LIMIT REMOVE FROM SERVICE.
- F. Turn the BLANKETROL III off and remove the test jumper.
- G. Allow the water temperature to fall below 42.0°C .
- H. Place a jumper on the test port in the location marked HS.
- I. Turn the BLANKETROL III on and monitor the temperature on the water temperature display as the water is heated.
- J. The BLANKETROL III should heat the water to $44.0^{\circ}\text{C} \pm 2.0^{\circ}\text{C}$ and shut off; status should indicate HIGH LIMIT REMOVE FROM SERVICE.
- K. Turn the BLANKETROL III off and remove the test jumper.
- L. Allow the water temperature to fall below 42.0°C .
- M. Place jumpers on the test port in the locations marked HC and JP2.
- N. Turn the unit on and monitor the temperature on the water temperature display as the water is heated.
- O. The BLANKETROL III should heat the water to $46.0^{\circ}\text{C} \pm 2.0^{\circ}\text{C}$ and shut off; status should indicate SNAP DISC REMOVE FROM SERVICE and PATIENT display should indicate EE02.
- P. Turn the BLANKETROL III off and remove the test jumper.
- Q. Allow the water temperature to fall below 42.0°C and turn the BLANKETROL III back on.
- R. Confirm that the thermostatic disc has reset by verifying that EE02 is not shown in the patient display.
- S. Press SILENCE ALARM button, TEMP SET button and increment button simultaneously to reset the alarm.

Note: This step is required to reset the SNAP DISC REMOVE FROM SERVICE alarm only.

4-9. TEMPERATURE ACCURACY CHECK

For temperature accuracy and verification, we recommend using GENTHERM's TFRW 86171 Trimatic. Follow directions enclosed in the Trimatic to test temperature accuracy.

4-10. DISPOSAL OF THE BLANKETROL II UNIT

Medical devices that have come in contact with patients contain the risk of bio-contamination. This device generates no waste products or residues under normal use and normal cleaning routines. Follow local State and Hospital guidelines regarding disposal of medical devices at the end of their useful lives.

SECTION 5. FIELD REPAIR/SERVICE OF THE BLANKETROL III UNIT

WARNING

- Always **unplug the unit** before accessing internal components during service. **Failure to unplug the unit could result in electric shock.**
- The repair, calibration, and servicing of the BLANKETROL III should be performed by qualified Medical Equipment Service Technicians, Certified Biomedical Electronics Technicians, or Certified Clinical Engineers familiar with good repair practices for servicing medical devices, and in accordance with instructions contained in this manual. **Improper repair can result in damage to the BLANKETROL III system and patient injury.**
- **Before** returning the BLANKETROL III to patient use **after** repairs, the FIRST TIME SET-UP/SYSTEM TEST ROUTINE in Section 2 must **always** be performed. **Improper repair and inadequate maintenance can result in damage to the BLANKETROL III system and patient injury.**

Complete the applicable parts of the First Time Set-Up/System Test Routine described in Section (2-3.) to determine that the unit is operating.

5-1. INTRODUCTION

This section describes the repair and service task maintenance personnel can complete in the field if a problem should occur. These tasks include servicing any of the following:

1. Membrane control panel
2. Heater
3. Microprocessor board
4. On/off power switch
5. Pump housing
6. Pump motor
7. Thermal disc
8. Upper and lower water manifolds
9. Water filter assembly
10. Water flow indicator
11. Water level sensor
12. Water temperature sensor
13. Beeper Assembly

Maintenance and service activities will sometimes overlap. In general, maintenance refers to any activity that does not require a certified technician. Maintenance may be performed by healthcare personnel or by other trained persons.

The following actions are considered maintenance:

1. Inspecting, cleaning, and disinfecting the exterior
2. Adding or replacing water
3. Replacing hoses
4. Cleaning hoses, blankets
5. Draining reservoirs

Service refers to any activity that requires a Medical Equipment Service Technician, Certified Biomedical Electronics Technician, or a Certified Clinical Engineer. The following actions are considered service:

1. Equipment or parts replacement
2. Repairs
3. System testing
4. Cleaning & disinfecting water reservoirs
5. Replacing hoses (air, water), cords, and other accessories

The description of each task includes the tools, the procedures, and the precautions necessary to complete the task. Maintenance, repair, and/or service of the BLANKETROL III by qualified maintenance/technical personnel **will not** void the warranty of the unit.

Figures (5-1.), (6-2.), and (6-4.) highlight the interior components of the BLANKETROL III unit. The internal components referenced in Figure (5-1.) are as follows:

- A. Upper manifold (return)
- B. Water temperature sensor
- C. Lower manifold (outlet)
- D. Pump housing assembly
- E. Transformer
- F. Compressor
- G. Compressor electrical box
- H. Filter drier
- I. Refrigeration solenoid valve
- J. Starting capacitor
- K. Condenser fan blade
- L. Hot gas by-pass valve
- M. Terminal Block
- N. Flow switch
- O. Heater
- P. Thermal disc
- Q. Reservoir

If any part that is removed from the unit is still under warranty, return it to the factory as described in Section (6.). If it is not under warranty, dispose of the part as required.

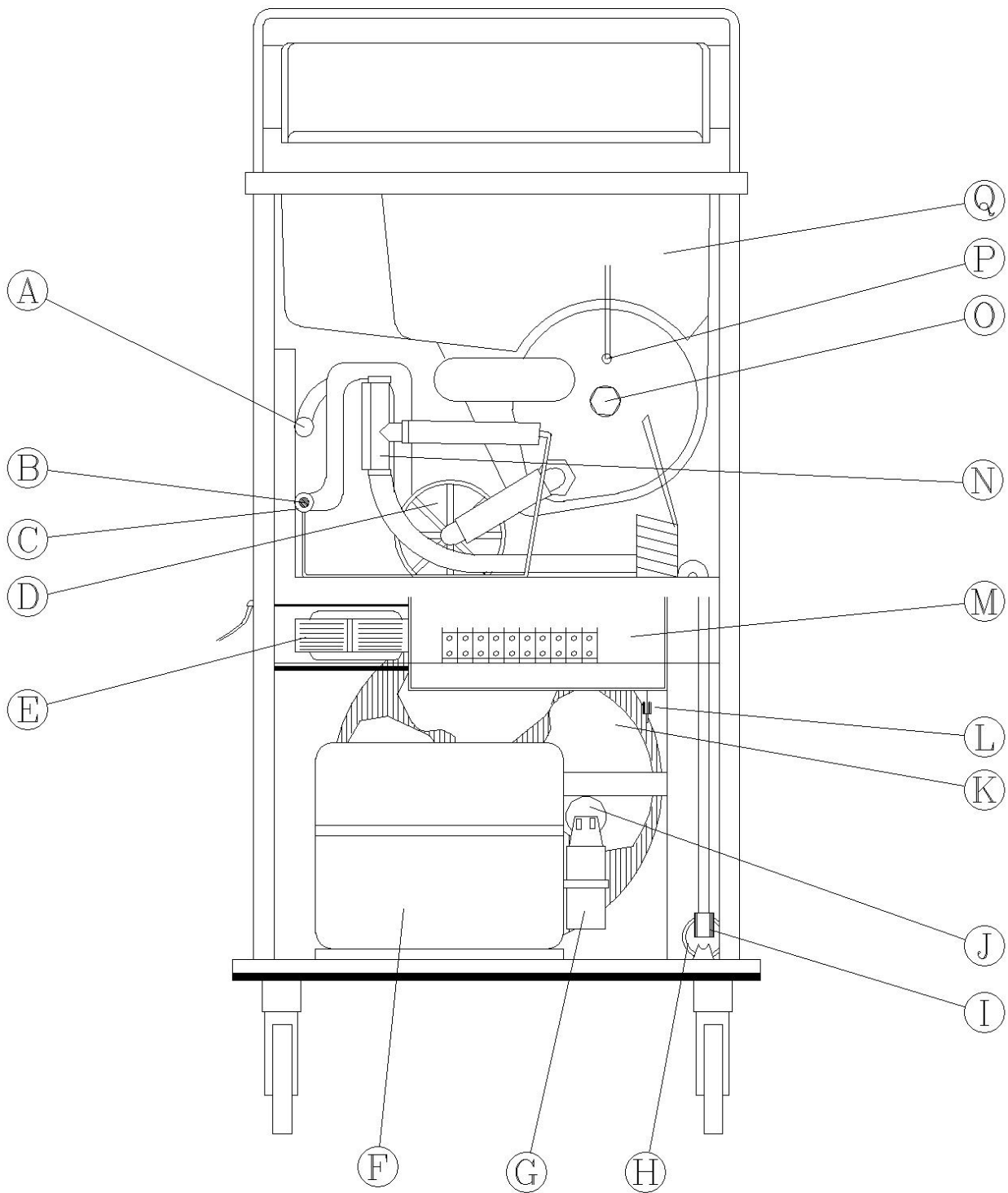

FIGURE 5-1. BLANKETROL III - EXPOSED REAR VIEW

5-2. ACCESS TO THE INTERIOR OF THE BLANKETROL III UNIT

All internal operating components are readily accessible by removing the rear enclosure panel, removing the top of the unit, or extending the front storage drawer.

NOTE: DRAIN THE RESERVOIR AND DISCONNECT THE POWER CORD FROM THE POWER SOURCE BEFORE REMOVING ANY PART FROM THE UNIT.

5-2.1. Removing the Rear Enclosure Panel**WARNING**

- Always **unplug the unit** before accessing internal components during service. **Failure to unplug the unit could result in electric shock.**

- A. Remove the four Phillips screws, one in each corner on the rear enclosure panel.
- B. Guide the rear enclosure panel outward and downward from the bottom so that the panel clears the bottom edge of the top assembly.
- C. Set the rear enclosure panel and screws to the side.
- D. Installation is reverse of removal.

5-2.2. Removing the Top of the Unit**WARNING**

- Always **unplug the unit** before accessing internal components during service. **Failure to unplug the unit could result in electric shock.**
- Working with electronic boards, plugs, and cables requires delicate handling. Proper **electrostatic discharge (ESD)** procedures should be followed during replacement of any electronic board. **Failure to do so may result in damage to the board.**

- A. Carefully pry off the caps of the two screws on the left side and right side of the unit.
- B. Remove the four Phillips screws.
- C. Carefully lift up the front edge of the top of the unit so that you can see the stainless steel divider reservoir cover. The microprocessor board is attached to the top assembly.
- D. Ensure that no water drips on the electrical components.

After the screws on the side of the unit are removed and the top is lifted, there are two ways to disconnect the top from the base depending upon what part is to be replaced.

If work is to be done with the microprocessor board, the membrane control panel, or anything related to the top assembly, disconnect the cables from the microprocessor board. Go to Section (5-2.4.).

5-2.3. Removing the Left Side Enclosure Panel**WARNING**

- Always **unplug the unit** before accessing internal components during service. **Failure to unplug the unit could result in electric shock.**

- A. Remove the rear enclosure panel and the top of the unit. See Sections 5-2.1 and 5-2.2.

- B. Remove the two Phillips screws that secure the back of the left side enclosure panel and set to the side.
- C. Push the rear portion of the left side enclosure panel out so it is clear of the device's frame. Then push the panel toward the front of the device so that it detaches from the device. A rubber mallet may be needed to detach the panel from the device.
- D. Set the left side enclosure panel to the side.
- E. Installation is reverse of removal.

5-2.4. Disconnecting the Cables from the Microprocessor Board

WARNING
<ul style="list-style-type: none"> • Always unplug the unit before accessing internal components during service. Failure to unplug the unit could result in electric shock. • Working with electronic boards, plugs, and cables requires delicate handling. Proper electrostatic discharge (ESD) procedures should be followed during replacement of any electronic board. Failure to do so may result in damage to the board.

- A. Remove the top of the unit per Section 5-2.2.
- B. Tilt the front edge of the top of the unit back, rotate and stably rest the top so that the fill lid is on the stainless-steel reservoir top.

NOTE: DO NOT BEND ANY OF THE TERMINALS.

- C. Locate the following connectors on the microprocessor board and disconnect them by pinching the sides to disengage the connector lock, as required:

CONNECTOR	J POSITION
Red 2-position flow switch connector	J9 position
Red 9-position connector	J8 position
White 2-position connector	J4 position
White 12-position connector	J1 position
Red 3-position connector	J3 position
Blue 11-position membrane ribbon cable connector	J7 position
Black 2-position connector	J12 position
USB cable	J6 position

- D. Locate the black 2-position connector at J5 in the middle of the microprocessor board. This is a friction fit connector and may require needle nose pliers to remove.
- E. Remove the 4 power supply wires by loosening the screws that tighten the wires in place.
- F. The top of the unit may now be removed from the base.

5-2.5. Extending the Front Storage Drawer

WARNING
<ul style="list-style-type: none"> • Always unplug the unit before accessing internal components during service. Failure to unplug the unit could result in electric shock.

- A. Open the front storage drawer.
- B. Locate the 10-32 Phillips head screw on the right-inside edge of the drawer. Number 6 in Figure (6-4.).
- C. Using a Phillips head screwdriver, remove the 10-32 screw and set it aside.
- D. Tilt the drawer all the way down to expose the front interior of the unit.

5-2.6. Repositioning the Front Storage Drawer

WARNING

- Always **unplug the unit** before accessing internal components during service. **Failure to unplug the unit could result in electric shock.**

- A. Slightly close the front storage drawer.
- B. Using a Phillips head screwdriver, replace the 10-32 screw on the right side of the inside of the panel.

5-3. REPLACEMENT OF THE HEATER

WARNING

- Always **unplug the unit** before accessing internal components during service. **Failure to unplug the unit could result in electric shock.**

CAUTION

- Always drain the BLANKETROL III to a sanitary drain because **bio-contaminants** may be present in the unit's water supply.

- A. Drain the reservoir as described in Section (4-2.1.).
- B. Remove the rear enclosure panel as described in Section (5-2.1.).
- C. Locate the heater inserted in the center of the reservoir plate and the lead wires that go to the electrical box, as shown in Figure (5-1-O.). Fiberglass tubing covers the lead wires.
- D. Disconnect the lead wires and pull through fiber glass tubing.
- E. Using a 7/8" wrench, unscrew and remove the heater cartridge.
- F. Insert and tighten the replacement heater in the evaporator coil assembly.
- G. Replace fiberglass tubing over wires.
- H. Re-connect the wires from the heater to proper terminal.
- I. Replace the rear enclosure panel as described in Section (5-2.1.).
- J. Refill the reservoir as described in Section (4-2.2).

5-4. REPLACEMENT OF THE WATER FILTER ASSEMBLY

WARNING

- Always **unplug the unit** before accessing internal components during service. **Failure to unplug the unit could result in electric shock.**

- A. Refer Section 4-3.

CAUTION

- Always drain the BLANKETROL III to a sanitary drain because **bio-contaminants** may be present in the unit's water supply.

5-5. REPLACEMENT OF THE PUMP HOUSING

WARNING

- Always **unplug the unit** before accessing internal components during service. **Failure to unplug the unit could result in electric shock.**

- A. Obtain replacement pump housing.
B. Disconnect the Blanketrol® III unit from Mains power

CAUTION

- Always drain the BLANKETROL III to a sanitary drain because **bio-contaminants** may be present in the unit's water supply.

- C. Drain the reservoir as described in Section (4-2.1.).
D. Remove the rear enclosure panel as described in Section (5-2.1.).
E. Locate the white pump housing assembly and the inlet and outlet hose connections at the center left of the back of the unit as shown in Figure (5-1-D.).
F. Disconnect the hose at the inlet of the pump housing by loosening the screw clamp. **Be careful:** there may be water in the hose.
E. Disconnect the hose at the outlet of the pump housing by loosening the screw clamp near the top of the white pump housing.
F. Using a Phillips screwdriver, remove the four screws around the edge of the pump housing. **Be careful:** there may be water in the housing assembly. Set the screws aside.
G. Pull the complete pump housing forward and remove.
H. Insert the replacement housing assembly. Position the housing so that the outlet is pointing upward, and the screw holes are aligned.
I. Reinsert the four screws around the edge of the housing.
J. Tighten the screws in the following order: top, bottom, right, and then left. Do not tighten the screws sequentially.
K. Reconnect the hose of the water manifold to the outlet at the top of the pump housing and tighten the screw clamp.
L. Reconnect the hose of the water reservoir to the inlet at the center of the pump housing and tighten the screw clamp.
M. If needed, replace the water filter as described in Section (4-3.).
N. Refill the reservoir as described in Section (4-2.2.).

- O. Replace the rear enclosure panel as described in Section (5-2.1.).

5-6. REPLACEMENT OF THE PUMP MOTOR

WARNING

- Always **unplug the unit** before accessing internal components during service. **Failure to unplug the unit could result in electric shock.**

- A. Obtain a replacement pump motor.
- B. Disconnect the Blanketrol® III unit from Mains power.

CAUTION

- Always drain the BLANKETROL III to a sanitary drain because **bio-contaminants** may be present in the unit's water supply.

- C. Drain the reservoir as described in Section (4-2.1.).
- D. Remove the rear enclosure panel as described in Section (5-2.1.).
- E. Remove the left side enclosure panel as described in Section (5-2.3.).
- F. Extend the front storage drawer as described in Section (5-2.5.).
- G. Locate the pump housing assembly with inlet and outlet hose connections at the center left of the rear of the unit as shown in Figure (5-1-D.).
- H. Disconnect the hose at the inlet and the outlet of the pump housing by loosening the screw clamps. There may be water in the lines.
- I. To remove Pump assembly:
- a. March Pump Only:
 - I. With the side panel removed, locate the mounting bolts securing the March pump.
 - II. Using a ratchet with a 7/16" wrench, loosen and remove the nuts and bolts securing the pump motor to the divider pan in the unit. The bolts are accessible from the front of the unit (accessible by extending the front storage drawer).
 - III. Catch each nut from the underside of the divider pan as each bolt is loosened. Set the nuts, bolts, and washers to the side.
 - b. Iwaki Pump only:
 - I. Using a Phillips head screwdriver, remove Phillips screws from underside of the divider pan securing pump to top surface of divider pan. Set mounting screws aside.

Note: The following step(s) requires ESD Protection when Handling Electrical Boards

- J. Using an 11/32" wrench, remove the two nuts from the faceplate of the electrical box and remove the faceplate from the two stand-offs. Set the nuts and faceplate to the side.
- K. Trace the three-wire cable from the pump motor to the electrical box. The cable enters the box from the right side.
- L. Locate the termination of the three wires. Reference the wiring diagram located on the electrical box.

- M. Disconnect and remove each of the wires from the electrical box (needle nose pliers may be required to disconnect fast-on connectors). The white and black (lead) wires are terminated with slide-off connectors. The green (ground) wire is terminated with an eyelet connector that is disconnected by unscrewing the ground screw.
- N. Loosen nut securing ground wires to the grounding lug using 5/16" wrench. Ensure other ground wires remain on the ground lug.
- NOTE: Do not to disturb any of the other wire connections.**
- O. Remove the wire tie that is securing the pump wire (lead wire). Cut the zip top which connects all the wire bundles. Pull the pump wires through the electrical wire grommet.
- P. Carefully remove the pump motor from the unit.
- Note: When replacing an lwaki pump with another lwaki pump, ensure that the rubber gasket located beneath the original pump motor is retained for reuse.**
- Note: In top two (2) and bottom two (2) holes of the panel, install four (4) 5/16" plastic plugs and silicone to prevent water from dripping.**
- Q. Connect the outlet hose of the pump first, then the inlet hose, tighten up the clamps.
- R. Replace the rubber gasket, aligning the holes of the gasket with the holes on the divider pan of the unit.
- S. Install the replacement pump motor over the rubber gasket being sure to align the mounting holes.
- T. Using the original mounting screws, secure the pump by inserting the screws into the threaded pump motor mount from the underside of the divider pan.
- U. Route the lwaki pump power wire in the same manner as the previous pump wires. Insert the white and black (lead) wires and the green (ground) wire through the electric box grommet (needle-nose pliers may be needed to attach the fast-on connectors). Secure the wires with wire ties.
- V. Route the ground wire from the pump motor to the ground lug and secure using original nut using 5/16" wrench. Route/connect the wires according to the wiring diagram.
- W. Fit the faceplate onto threaded posts protruding from the electrical box, pointing the cover lip up and away from the installer.
- X. Ensure that the faceplate of the electrical box may be pushed all the way in without pressing on any wires or components inside the electrical box compartment. Screw on 2 nuts that were removed in step J using the 11/32" nut driver. Tighten nuts securely.
- Y. Visually inspect all wiring to ensure no wires are pinched, stressed, or contacting sharp edges. Confirm that insulation on all wires is intact and connectors are properly seated.
- Z. Refill the reservoir as described in Section (4-2.2.). Check for leaks around the pump housing.
- AA. Plug the unit and Turn ON. Complete the applicable parts of the First Time Set-Up/System Test Routine in Section (2-3.) to determine that the pump is circulating the water. Check for leaks around the pump housing.
- AB. After successfully completing the leak test, Turn off and unplug unit.
- AC. Reposition the front storage drawer as described in Section (5-2.6.).

- AD. Replace the left side enclosure panel as described in Section (5-2.3.)
- AE. Replace the rear enclosure panel as described in Section (5-2.1.).

5-7. REPLACEMENT OF THE FLOW SWITCH**WARNING**

- Always **unplug the unit** before accessing internal components during service. **Failure to unplug the unit could result in electric shock.**

CAUTION

- Always drain the BLANKETROL III to a sanitary drain because **bio-contaminants** may be present in the unit's water supply.

- Obtain a replacement flow switch.
- Drain the reservoir as described in Section (4-2.1.).
- Remove the rear enclosure panel as described in Section (5-2.1.).
- Locate the flow switch assembly.
- Remove the two (2) hose clamps, one (1) from the inlet and one (1) from the outlet fitting.
- Remove the inlet and the outlet fitting from the flow switch.
- Carefully pry off and remove the two (2) snap caps from the left side and the right side of the unit.
- Remove the four (4) Phillips screws.
- Carefully lift up the front edge of the top of the unit so that you can see the wire harnesses and their termination points on the microprocessor board.
- Locate and disconnect the two (2) position flow switch connector (J9 position) from the microprocessor board.
- Feed the flow switch wire harness carefully towards the flow switch, removing any wire ties as needed.
- Discard the old flow switch.
- Install the new flow switch by reversing the removal instructions above.
- Refill the reservoir as described in Section (4-2.2.).
- Replace the rear enclosure panel as described in Section (5-2.1.).

5-8. REPLACEMENT OF THE WATER TEMPERATURE SENSOR**WARNING**

- Always **unplug the unit** before accessing internal components during service. **Failure to unplug the unit could result in electric shock.**

- Obtain replacement water temperature sensor.

CAUTION

- Always drain the BLANKETROL III to a sanitary drain because **bio-contaminants** may be present in the unit's water supply.
- B. Drain the reservoir as described in Section (4-2.1.).
 - C. Remove the rear enclosure panel as described in Section (5-2.1.).
 - D. Locate the water temperature sensor in the end of lower water manifold and 4-wire connector on the left side of the back of the unit as shown in Figure (5-1-B).
 - E. Disconnect the water temperature sensor by pulling apart the plug.
 - F. Using a 7/16" wrench, unscrew the nut of the water temperature sensor at the water manifold and remove the water temperature sensor. There may be water in the line.
 - G. Insert and tighten the replacement water temperature sensor into the lower water manifold. Use Teflon tape on the sensor threads.
 - H. Connect the water temperature sensor by inserting the plug.
 - I. Refill the reservoir as described in Section (4-2.2.).
 - J. Replace the rear enclosure panel as described in Section (5-2.1.).

5-9. REPLACEMENT OF THE UPPER AND/OR LOWER WATER MANIFOLDS**WARNING**

- Always **unplug the unit** before accessing internal components during service. **Failure to unplug the unit could result in electric shock.**

- A. Drain the reservoir as described in Section (4-2.1.).

CAUTION

- Always drain the BLANKETROL III to a sanitary drain because **bio-contaminants** may be present in the unit's water supply.

- B. Remove the rear enclosure panel as described in Section (5-2.1.).
- C. Locate the copper water manifold to be replaced. The two manifolds, one lower and one upper, are wrapped in black foam and are secured to the left side (viewed from the rear) of the unit as shown in Figure (5-1-A. & 5-1-C.). The lower manifold is connected to the male quick-disconnect fittings and to the hose from the pump. The water temperature sensor is inserted in the end of the lower manifold. The by-pass at the other end of the lower manifold connects to the water reservoir. The upper manifold is connected to the female quick-disconnect fittings and the hose to the water flow indicator. To replace the lower manifold, continue to Step E. To replace the upper manifold, go to Step R.
- D. Remove the water temperature sensor as described in Section (5-8.), Steps D - F. Set to one side.
- E. Disconnect the hose at the copper elbow of the lower manifold by loosening the screw clamp. Be sure to exercise caution there may be water in the line.
- F. Using a 9/16" open end wrench, unscrew and remove the three male quick-disconnect fittings from the outside of the unit.

- G. Disconnect the by-pass line from the reservoir. Remove the clamp from the clear plastic by-pass line and disconnect the bypass line.
- H. Carefully work the lower manifold from the holes on the side of the unit and withdraw it from the back of the unit.
- I. Insert the replacement lower manifold so that the three outlets align with the three holes on the side of the unit, the outlet for the water temperature sensor points to the back of the unit, the copper elbow points toward the front of the unit and the clear plastic bypass line runs from the front of the unit toward the reservoir. Appropriately apply Teflon tape to all threaded connections.
- J. Reconnect the three male quick-disconnect fittings on the bottom row starting with the fitting farthest from the water flow indicator. Check that the fittings are tight.
- K. Connect the hose from the pump housing to the copper elbow of the manifold and tighten the clamp.
- L. Remove the used white Teflon tape from around the threads of the water temperature sensor. Apply new Teflon tape.
- M. Reinsert the water temperature sensor.
- N. Insert the bypass tubing into the copper tube from the reservoir.
- O. Secure the clear plastic tube with the plastic "snapper" clamp.

To replace the upper manifold, continue to Step P. If only replacing the lower manifold, finish with Steps W-X.

- P. Disconnect the hose at the copper elbow of the upper manifold by loosening the screw clamp. Be careful: there may be water in the line.
- Q. Using a 9/16" wrench, unscrew and remove the three female quick-disconnect fittings from the outside of the unit. Set aside.
- R. Carefully work the manifold from the holes on the side of the unit and remove it from the back of the unit.
- S. Apply Teflon tape around the threaded nipples of the replacement manifold.
- T. Insert the replacement upper manifold so the three nipples align with the three holes on the side of the unit and the copper elbow points toward the front of the unit.
- U. Reconnect the three female quick-disconnect fittings on the top row starting with the fitting farthest from the water flow indicator. Check that the fittings are screwed tight.
- V. Connect the hose from the water flow indicator to the copper elbow and tighten the screw clamp.
- W. Refill the reservoir as described in Section (4-2.2.).
- X. Replace the rear enclosure panel as described in Section (5-2.1.).

5-10. REPLACEMENT OF THE COMPRESSOR STARTING CAPACITOR, THE OVERLOAD PROTECTOR, AND/OR THE COMPRESSOR RELAY

NOTE: For replacement of these parts call GENTHERM Technical Service.

5-11. REPLACEMENT OF THE THERMAL DISC OVER TEMPERATURE DEVICE**WARNING**

- Always **unplug the unit** before accessing internal components during service.
Failure to unplug the unit could result in electric shock.

- Obtain a replacement thermal disc.
- Remove the rear enclosure panel as described in Section (5-2.1.).
- Locate the thermal disc on the reservoir plate.
- Push back or cut back the black insulation.
- Disconnect the two slide-on connectors.
- Using a Phillips screwdriver remove the two screws at the top and bottom of the thermal disc.
- Remove the thermal disc.
- Install the replacement thermal disc.
- Replace and tighten the two screws.
- Insert the slide-on connector to the insulated terminal (white wire) and (orange wire) of the thermal disc.
- Replace the rear enclosure panel as described in Section (5-2.1.).

5-12. REPLACEMENT OR CLEANING OF THE WATER FLOW INDICATOR ASSEMBLY**WARNING**

- Always **unplug the unit** before accessing internal components during service.
Failure to unplug the unit could result in electric shock.

CAUTION

- Always drain the BLANKETROL III to a sanitary drain because **bio-contaminants** may be present in the unit's water supply.

- Obtain a replacement water flow indicator.
- Drain the reservoir as described in Section (4-2.1.).
- Extend the front storage drawer as described in Section (5-2.5.).
- Locate the water flow indicator assembly (number 12 in Figure 6-2.) attached to the right side (front view) wall, the connecting hose at its top left and the connecting hose at its top right.
- Disconnect the hose at the top left of the water flow indicator by loosening the screw clamp. Be careful; there may be water in the line.
- Disconnect the hose at the top right of the water flow indicator by loosening the screw clamp. Be careful; there may be water in the line.
- Using a Phillips screwdriver, remove the two screws that hold the water flow indicator to the manifold pan on the outside right wall. Catch the water flow indicator as it falls

- to the inside. If the water flow indicator is to be replaced, go to Step M. If the water flow indicator is to be cleaned and then reinserted, go to Step H.
- H. Remove the four remaining Phillips head screws around the face of the water flow indicator. Set the screws to the side.
 - I. Disassemble the parts of the water flow indicator. Do not lose the large black O-ring.
 - J. Rinse thoroughly with clean water. A small brush may be used to clean the parts.
 - K. Reassemble the parts.
 - L. Reinsert the four screws.
 - M. Position the replacement water flow indicator inside the unit so that the screw holes are aligned on the right side wall and the plastic elbows point toward the back of the unit.
 - N. Insert and tighten the two Phillips head screws from the outside.
 - O. Connect the hose from the upper manifold to the top left plastic elbow and tighten the clamp.
 - P. Connect the hose from the water filter to the top right plastic elbow and tighten the clamp.
 - Q. Refill the water reservoir as described in Section (4-2.2.).
 - R. Reposition the front storage drawer as described in Section (5-2.6).

5-13. REPLACEMENT OF THE I/O POWER SWITCH

WARNING

- | |
|--|
| <ul style="list-style-type: none">• Always unplug the unit before accessing internal components during service.
Failure to unplug the unit could result in electric shock. |
|--|

- A. Obtain the replacement I/O power switch.
 - B. Extend the front storage drawer as described in Section (5-2.5.).
 - C. Locate the square I/O power switch on the left side of the front panel of the unit. Number 13 in Figure (6-2.).
 - D. Work the power switch and attached cable to the outside of the unit by pressing together the tension clips on the top and bottom of the switch assembly. The tension clips are accessible by reaching inside the unit from the extended drawer opening.
 - E. Examine the placement of the wires on the power switch.
 - F. Disconnect the four slide-on connectors from the switch.
 - G. Position the replacement power switch into the unit so that the labels are upright and "I" is at the top.
 - H. Connect the wires in the same locations in which they were disconnected.
 - I. Work the power switch and attached cable to the inside of the unit by pressing together the tension clips on the top and bottom of the switch assembly.
 - J. Reposition the front storage drawer as described in Section (5-2.6.).
-

5-14. REPLACEMENT OF THE WATER LEVEL SENSOR ASSEMBLY**WARNING**

- Always **unplug the unit** before accessing internal components during service. **Failure to unplug the unit could result in electric shock.**

A. Obtain a replacement water level sensor.

CAUTION

- Always drain the BLANKETROL III to a sanitary drain because **bio-contaminants** may be present in the unit's water supply.

B. Drain the reservoir as described in Section (4-2.1.).

C. Remove the top of the unit as described in Section (5-2.2. & 5-2.4.) and disconnect cables from the power supply board.

D. Locate the water level sensor. Facing the unit, it is a square plate located in the center of the unit with two red wires leading to a 2-pin connector. Number 15 in Figure (6-2.).

E. Disconnect the water level sensor by pulling apart the white, 2-pin connector (J4 position).

F. Using a 5/16" wrench, remove the four nuts from the screw posts in the four corners of the water level sensor.

G. Remove the water level sensor by lifting upward.

H. Remove the black rubber gasket from the defective water level sensor and insert the gasket on the replacement water level sensor.

I. Insert the replacement water level sensor with the gasket into the hole so that the screw holes are aligned with the four screw posts.

J. Replace and tighten the four nuts on the screw posts.

K. Reconnect the white 2-pin connector.

L. Replace the top of the unit as described in Section (5-2.2.).

M. Refill the reservoir as described in Section (4-2.2.).

5-15. REPLACEMENT OF THE MICROPROCESSOR BOARD AND/OR THE MEMBRANE CONTROL PANEL**WARNING**

- Always **unplug the unit** before accessing internal components during service. **Failure to unplug the unit could result in electric shock.**
- Working with electronic boards, plugs, and cables requires delicate handling. Proper **electrostatic discharge (ESD)** procedure should be followed during replacement of any electronic board. **Failure to do so may result in damage to the board.**

Access to the membrane control panel requires first removing the microprocessor board.

A. Obtain the required replacement part: microprocessor board and/or membrane control panel.

B. Remove the top of the unit and disconnect all the cables from the microprocessor board. See Section (5-2.2. & 5-2.4.).

- C. Position the top of the unit at a work space, face down.
- D. Using a 5/16" wrench remove the six nuts around the edge of the board.
- E. Gently lift and remove the microprocessor board.
- F. Carefully set the microprocessor board aside.

If only the microprocessor board is to be replaced, go to Step K. If the membrane control panel is to be replaced, go to Step G.

- G. Using a 1/4" wrench, remove the six stand-offs. Remove the membrane control panel from the top assembly.

NOTE: BE CAREFUL NOT TO OVERTIGHTEN STANDOFFS.

- H. Appropriately insert the replacement membrane control panel into the top assembly, and re-secure standoffs.
- I. Check alignment of LED's on new microprocessor board and if needed make adjustments in order for LED's to shine through the windows on the membrane control panel.
- J. Position the microprocessor board to align with the membrane control panel.
- K. Connect the membrane ribbon cable to the 11-pin connector at J7 position on microprocessor board.

NOTE: BE CAREFUL NOT TO OVERTIGHTEN NUTS.

- L. Replace the nylon nuts; tighten the nuts.
- M. Reposition the top on the unit and reconnect the cables by referencing Section (5-2.2. & 5-2.4.). Reconnect the power wires on the terminal by referencing the wiring diagram, Figure (6-5. A) for 115V and Figure (6-5.B.) for 230V.
- N. Refill the water reservoir as described in Section (4-2.2.).

5-16. REPLACEMENT OF THE BEEPER ASSEMBLY

- A. Remove the left side enclosure panel per Section 5-2.3.
- B. Locate the beeper on the front side of the terminal block enclosure and underneath the divider pan.
- C. Remove the nuts securing the beeper and remove the defective beeper.
- D. Install the new beeper onto the PEM's on the front side of the terminal block and secure with the nuts.
- E. Feed and secure the beeper assembly wires to the microprocessor board as the defective beeper is secured.
- F. Discard the defective beeper and reinstall the enclosure panels and the top of the unit. Installation is reverse of removal.

5-17. REPLACEMENT OF THE POWER CORD

- A. Disconnect and remove each of the wires from the electrical box. The white and black wires are terminated with slide-off connector. The green wire is terminated with an eyelet connector that is disconnected by unscrewing the ground screw.

- B. Unfasten the power cord from the divider pan by removing the brass washer and 8/32x1/2" screw from the 3/8" nylon clamp.

NOTE: 230 VOLT only. Power Cord will be secured at the lower right corner of the mounting bracket located at the left side of the frame using one (1) 5/16" nylon clamp, one (1) 8/32x1/2" screw and one (1) brass washer.

- C. Remove the strain relief from the unit by depressing the tabs that extend into the unit.
- D. Remove the power cord from the unit.
- E. Insert new power cord into the strain relief and install strain relief back into the unit.
- F. Secure the power cord to the divider pan with (1) 3/8" nylon clamp (ID#50119), one (1) 8/32x1/2" screw (ID#60201), one (1) brass washer (ID#60632), then tighten. Feed the wires into the terminal block and wire according to the drawing.
- a. For 230 Volt: See NOTE above.
- G. Connect the wires in the same locations in which they were disconnected.

5-18. LEAKAGE CURRENT

The BLANKETROL III unit should periodically be checked for Leakage Current prior to general floor use. Using an electrical safety analyzer, measure the electrical Leakage Current under the following conditions: Power ON & Off, polarity normal and reverse. The Leakage Current should be less than 300 microamps under all conditions for 115 Volt. The Leakage Current should be less than 500 microamps under all conditions for 230 volts. If a BLANKETROL III unit has Leakage Current that exceeds 300 microamps in the 115V unit or has a significant increase in Leakage Current, the cause should be investigated, and individual components of the unit must be electrically isolated and measured. All readings may be affected by the age of the components, ambient temperature, and humidity.

5-18.1. Arranging the Equipment

- A. Plug the BLANKETROL III power cord into a Leakage Current tester and plug the tester into a power source.
- B. Attach the input lead wire of the tester to a grounding point of the BLANKETROL III unit.

5-18.2. Taking Measurements in Normal Polarity

- A. Set the tester to Normal Polarity.
- B. Push the power switch of the BLANKETROL III unit to the "I" position and record the Leakage Current.
- C. Set the BLANKETROL III unit so it is COOLING and record the Leakage Current.
To set the unit in the Cooling Cycle:
1. Press the power switch to the "I" position.
 2. Press the TEMP SET button.
 3. Press the Down arrow so the Set Point is a low number.
 4. Press the MANUAL CONTROL button.
- The Status Display must show **COOLING**.
- D. Set the BLANKETROL III unit so that it is HEATING and record the Leakage Current.
To set the unit in the heating cycle:
1. Press the power switch to the "I" position.
 2. Press the TEMP SET button.
 3. Press the Up arrow so the Set Point is a high number.

4. Press the MANUAL CONTROL button.
The Status Display must show **HEATING**.

5-18.3. Taking Measurements in Reverse Polarity

- A. Set the tester to Reverse Polarity.
 - B. Press the power switch of the BLANKETROL III unit to the "I" position and record the Leakage Current.
 - C. Set the BLANKETROL III unit so that it is COOLING and record the Leakage Current.
 - D. Set the BLANKETROL III unit so that it is HEATING and record the Leakage Current.
-

5-19. REFRIGERANT CHECK

The refrigerant check must be performed by a certified refrigeration technician. For assistance contact technical service as listed on page 10 in this manual.

5-20. TROUBLESHOOTING GUIDE

TROUBLESHOOTING GUIDE		
OBSERVATION	POSSIBLE PROBLEM	ACTION TO BE TAKEN
A. The power switch of the BLANKETROL III unit is set on, in "I" position, but does not light; the membrane control panel is blank.	Unit is unplugged No line voltage	Check that the power cord is plugged into a properly grounded hospital grade receptacle. Check for possible short in electrical system.
B. Each time the BLANKETROL III unit is set in "I" position, it snaps to the "O" position.	The circuit breaker built into the power switch is defective or tripped.	Check amperage at switch. a. If the amp reading is less than 15 amperes, the circuit breaker may be defective. b. If the amp reading is greater than 15 amperes, check the amp reading of the compressor and the heater. c. Check for short in unit.
C. The power switch is set to "I" position and illuminates, but the membrane control panel is blank/inoperable.	The transformer is defective. The microprocessor board is defective.	Replace the transformer and or the microprocessor board.
D. The power switch is set to "I" position and illuminates. The Status Display lights but the buttons are inoperable.	The 9-pin cable (J7 position on microprocessor board) between the microprocessor board and membrane control panel is disconnected.	Reconnect the 9-pin connector. See Section (5-15.).
E. Unit is on, any switch on the membrane control panel is pressed but does not stay set, or when the operating mode is changed a switch remains set, or when the TEMP SET switch is pressed another switch snaps on.	Membrane switch has failed.	Replace membrane control panel. See Section (5-15.).

TROUBLESHOOTING GUIDE		
OBSERVATION	POSSIBLE PROBLEM	ACTION TO BE TAKEN
F. When the TEST INDICATORS button is pressed, a part of the display does not light	LCD or LED has failed.	Replace microprocessor board. See section (5-15.).
G. Unit is on. When the TEST INDICATOR is pressed, the displays across the panel show an atypical pattern.	Microprocessor board malfunctions.	Replace microprocessor board. See Section (5-15.).
H. The probe from the patient is inserted but when operating in one of the automatic modes, the PATIENT display does not illuminate, and alarm doesn't sound.	The Set Point is out of the range of 30°C to 40°C (86°F to 104°F) and the Status Display is flashing Check Set Point. The probe is defective. Status Display flashes CHECK PROBE or BAD PROBE and sounds the alarm.	Go back to temp set and set desired patient temp between range of 30°C to 40°C (86°F to 104°F). Replace with a new 400 Series Probe.
H. The probe from the patient is inserted but when operating in one of the automatic modes, the PATIENT display does not illuminate and alarm doesn't sound. (cont.)	Cable from the 1/4 inch receptacle to microprocessor board is disconnected, Status Display flashes CHECK PROBE and the alarm sounds.	Reconnect cable (J8 position on microprocessor board).
	1/4 inch receptacle on side of unit is defective, Status Display flashes CHECK PROBE or BAD PROBE and the alarm sounds.	Replace the 1/4 inch Receptacle Assembly
I. The probe from the patient is inserted but when operating in <i>MANUAL CONTROL MODE</i> , the PATIENT display does not illuminate, and alarm doesn't sound.	The patient temperature is not within the appropriate temperature range.	Check the location and temperature of the probe.
	The probe is broken or defective.	Set the BLANKETROL III to <i>MONITOR ONLY MODE</i> to determine if the probe is broken or defective.

TROUBLESHOOTING GUIDE		
OBSERVATION	POSSIBLE PROBLEM	ACTION TO BE TAKEN
J. The probe from the patient is inserted but when operating in <i>MONITOR ONLY MODE</i> , the PATIENT display doesn't illuminate, and alarm doesn't sound.	Other than a 400 Series probe was connected to the 1/4 inch receptacle.	Replace with the correct 400 Series probe.
	The patient temperature is not within the appropriate temperature range.	Check the location and temperature of the probe.
K. The probe from the patient is inserted but when operating in the one of the automatic control modes, the PATIENT display goes blank, alarm sounds, and the Status Display reads CHECK PROBE or BAD PROBE.	Other than a 400 Series probe was connected to the 1/4 inch receptacle.	Replace with the correct 400 Series probe (refer to Table (6-8.)).
	The patient probe has become dislodged from the patient and sensing a temperature below 30°C (86°F).	Reinsert probe into patient.
	The probe is defective.	Replace probe with a new 400 Series probe.
	Cable from the 1/4 inch receptacle to microprocessor board is disconnected.	Reconnect cable. See Section (5-15.).
L. The unit is operating in one of the three modes and the PATIENT display shows an erratic display.	1/4 inch receptacle on side of unit is defective.	Replace 1/4 inch receptacle assembly.
	Patient probe is improperly attached to patient.	Check the placement of the probe. See Section (3-2.).
	The patient probe is defective.	Replace with a new 400 Series probe.
M. The unit is operating in <i>MANUAL CONTROL MODE</i> or one of the automatic modes and the WATER display	Microprocessor board is defective.	Replace the microprocessor board. See Section (5-15.).
	Water temperature sensor is defective.	Replace water temperature sensor. See Section (5-8.).

TROUBLESHOOTING GUIDE		
OBSERVATION	POSSIBLE PROBLEM	ACTION TO BE TAKEN
shows an erratic display.		
N. The unit is operating in one of the three modes, the unit momentarily blanks and then the Status Display flashes CHECK SETPT.	Low line voltage or power source.	Check line voltage. Reset Set Point display and resume operations.
O. The unit is operating in one of the control modes. When cycling to <i>Cool</i> mode, all displays flicker on and off, the unit goes to CHECK SETPT in the Status Display or SENSOR FAULT REMOVE FROM SERVICE or HIGH LIMIT REMOVE FROM SERVICE.	Low line voltage or power source.	Check line voltage. Reset Set Point display and resume operations.
P. Unit is operating in <i>AUTOMATIC</i> or <i>MANUAL MODE</i> , the Status Display flashes HIGH LIMIT REMOVE FROM SERVICE.	<p>The <i>High Limit Safety</i> device is triggered which shuts down the unit when the water in the BLANKETROL III equipment reaches 44.0°C +/- 2.0°C (111.2°F +/- 3.6°F) due to defective control.</p> <p>Water not circulating due to internal clogged by-pass.</p>	<p>Replace microprocessor board. See Section (5-15.).</p> <p>Turn the unit OFF, force compressed air in the male outlets.</p>
Q. Unit is operating in <i>AUTOMATIC</i> or <i>MANUAL MODE</i> , the Status Display flashes SNAP DISC REMOVE FROM SERVICE and PATIENT displays EE02.	The Snap Disc high limit safety device is triggered which shuts down the unit when the water in the reservoir reaches 46.0°C +/- 2.0°C (114.8°F +/- 3.6°F).	<p>Replace microprocessor board. See Section (5-15.).</p> <p>Replace Snap disc.</p>
	Pump not working	Check pump.

TROUBLESHOOTING GUIDE		
OBSERVATION	POSSIBLE PROBLEM	ACTION TO BE TAKEN
R. Unit is operating in one of the control modes; the Status Display flashes LOW LIMIT REMOVE FROM SERVICE.	The back-up low limit safety device is triggered which shuts down the unit when the water in the BLANKETROL III equipment reaches 2.0°C ± 2.0°C (35.6°F ± 3.6°F) because more than one of the following has occurred:	Replace microprocessor board. See Section (5-15.).
	Defective Microprocessor board. Defective water temperature sensor.	Replace water temperature sensor. See Section (5-8.).
S. Unit operating in one of the control modes, the Status Display flashes SENSOR FAULT REMOVE FROM SERVICE.	Water temperature sensor is defective	Replace water temperature sensor. See Section (5-8.).
T. Unit is set to operate in a control mode; the water flow indicator does not move, i.e.: water not circulating.	Operator error; buttons not set correctly.	Correctly set buttons. See Section (3.).
	Defective pump.	Replace the pump.
	Disengaged quick-disconnect fittings.	Check all fittings for proper fit. See Section (2-3.).
	Kink in connecting hose and/or blanket	Straighten out the hose.
T. Unit is set to operate in a control mode; the water flow indicator does not move, i.e.: water not circulating. (cont.)	Clogged water filter	Replace water filter. See Section (4-3.).
	Clogged tubing of blankets.	Use forced air to drain blankets.
	Clogged couplings.	Use forced air to clear couplings.

TROUBLESHOOTING GUIDE		
OBSERVATION	POSSIBLE PROBLEM	ACTION TO BE TAKEN
U. Unit is set to operate in a control mode. Blanket does not cool.	Operator error; switches not set correctly.	Correctly set switch. See Section (3.).
	Water not circulating.	See Observation T.
	Compressor running but not cooling.	Check for leak. Recharge system. Check solenoid valve. (Tasks to be done by a qualified refrigeration technician.) Check solenoids in-line fuse located at J1 position, pin 11 (violet wire). Refer to wiring diagram.
	Compressor not running	Check for voltage compressor: a. If line voltage is present. b. If line voltage is not present: Replace micro-processor board. See Section (5-15.).
V. Unit is set to operate in a control mode. Blanket does not heat.	Operator error; switches not set correctly.	Correctly set switches. See Section (3.).
	Water not circulating.	See Observation T.
	Defective heater.	Replace heater. See Section (5-3.).
W. Unit is set to operate in a control mode. PATIENT temp display or WATER temp display not accurate or jumps up and down.	Defective microprocessor board.	Replace microprocessor board. See Section (5-15.).

SECTION 6. PARTS INFORMATION

6-1. INTRODUCTION

This section outlines information for ordering, shipping and replacing parts of the BLANKETROL III unit, Model 233. Identification of parts and components are shown in Figures (6-1.) and (6-3.). The numbers in Figures (6-2.) and (6-4.) correspond to the numbers in the left column of the accompanying parts list in Figures (6-1.) and (6-3.). Figures (6-5.) to (6-7.) diagram the functional operation of the unit and Table (6-8.), lists the BLANKETROL III System equipment and accessories.

6-2. ORDERING INFORMATION FOR REPLACEMENT PARTS

Replacement parts are available directly from GENTHERM or through our authorized BLANKETROL III dealer. When ordering parts, specify the replacement part number as well as the serial number of your unit located on the identification plate on the rear bumper. There is no minimum order requirement for replacement parts. Section (6-3.) outlines the recommended replacement parts inventory.

It is strongly recommended that all parts be replaced with parts purchased from GENTHERM. Use of other parts could void the warranty on the unit and possibly damage the unit.

6-3. RECOMMENDED REPLACEMENT PARTS INVENTORY

Qty.	Description
1	1/8" Quick-Disconnect Socket Fitting
1	1/8" Quick-Disconnect Plug Fitting
1	Water Level Sensor Assy.
1	3C Pump Housing Assy.
1	Water Temp. Sensor
1	Hi Temp Thermostat
1	Heater - 800W (115V)
1	Heater - 800W (230V)
1	Water Filter Assy.
1	Nylon Strap Assy.
1 pkg of 5	15 Amp Fuse** (115V)
1 pkg of 5	250 mAmp Fuse** (115V)
1 pkg of 5	8 Amp Fuse** (230V)
1 pkg of 5	125 mAmp Fuse** (230V)
1 pkg of 5	½ Amp Slow Blow Fuse (115V)
1 pkg of 5	¼ Amp Slow Blow Fuse (230V)

****ONLY** "UL Listed" fuses are to be used.

6-4. RETURNING PARTS UNDER WARRANTY

All parts are covered by a two (2) year warranty. To replace parts during the warranty period*, send the part prepaid to:

Gentherm Medical, LLC
12011 Mosteller Road
Cincinnati, Ohio 45241
Tel: 1-800-989-7373
Fax: (513) 772-9119

To qualify for credit, warranty parts should be tagged with the following information:

1. The invoice number under which the unit/part was purchased
2. Cause of failure
3. Serial Number of Unit

How to read serial numbers:

Example: 121-3-60000

- 12 indicates a manufacturing date of the year 2012
- 1 indicates the quarter (first)
- -3- means BLANKETROL III, Model 233
- 60000 indicates that this is the 60,000th unit of a certain model

4. Date of installation or purchase
5. Return Materials Authorization (RMA) number**

*Additional third year warranty is available at the time of purchase.

** You **must** first obtain an RMA number by calling the factory prior to returning.

6-5. SHIPPING PARTS

Parts to be returned to the factory must be carefully packaged, especially the control board. This board should be cushioned in static safe packaging material to prevent damage from Electro Static Discharge (ESD).

***NOTE: SHIPPING DAMAGE WILL BE THE
RESPONSIBILITY OF THE SHIPPER.
INSURE IF NECESSARY.***

***NOTE: IF CONTROL BOARD IS NOT SHIPPED IN
STATIC SAFE PACKAGING, WARRANTY
WILL BE VOID.***

If shipping entire unit, the entire system **must** be drained before shipping.

INTERNAL EXPLODED - FRONT VIEW

<u>Index #</u>	<u>Description</u>
1.	White Reservoir Lid.
2.	1/4 Inch Receptacle ("Probe Jack") Assembly
3.	USB Cable
4.	Membrane Control Panel (115V and P/N 86204) Membrane Control Panel (230V and P/N 86102)
5.	Top Assembly (115V) Top Assembly (230V)
6.	White Reservoir Lid Assembly (115V) White Reservoir Lid Assembly (230V)
7.	Strain Relief
8.	Manifold Pan
9.	1/8" Socket Quick-Disconnect Fitting (Female)
10.	1/8" Plug Quick-Disconnect Fitting (Male)
11.	12 ft. Lead-in Power Cord with Plug (115V) 12 ft. Lead-in Power Cord with Plug (230V) 12 ft. Lead-in Brazil std. Power Cord 12 ft. Lead-in British std. Power Cord
12.	Water Flow Indicator Assembly
13.	Power Switch with Circuit Breaker -15 Amp. (115V) Power Switch with Circuit Breaker -10 Amp. (230V)
14.	Fill Spout Gasket
15.	Water Level Sensor Assembly
16.	Microprocessor Board (115V) Microprocessor Board (230V)

FIGURE 6-1. PARTS LIST A

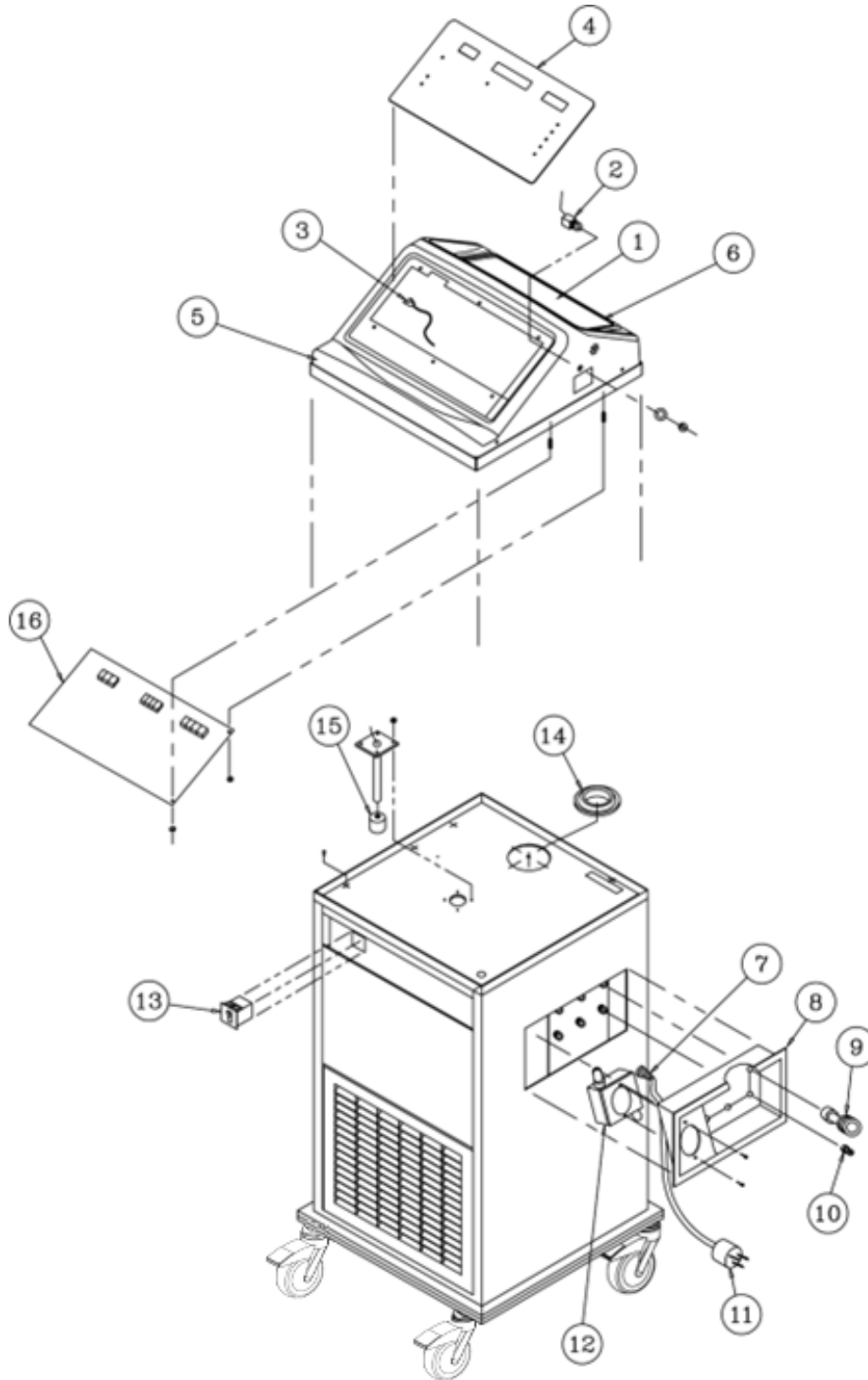

FIGURE 6-2. BLANKETROL III - INTERNAL EXPLODED - FRONT VIEW

INTERNAL EXPLODED - REAR VIEW

<u>Index #</u>	<u>Description</u>
1.	Top Assembly (115V and P/N 86204) Top Assembly (230V and P/N 86102)
2.	Patient Probe Label
3.	Screw
4.	Snap Cap
5.	Overflow Drain Hose Barb
6.	Drawer Stop - 8-32 x 1/2
7.	Shoulder Bolt
8.	Nylon Shoulder Washer
9.	Storage Drawer Assembly
10.	Grill
11.	Condenser Fan Blade
12.	Condenser Fan Motor (115V) Condenser Fan Motor (230V)
13.	Hot Gas By-Pass Valve
14.	Condenser
15.	4" Casters (Locking)
16.	Drier
17.	Solenoid Valve Body Solenoid Valve Coil (115V) Solenoid Valve Coil (230V)
18.	Compressor (115V) Compressor (230V)
19.	Terminal Block
20.	Transformer Assembly (115V) Transformer Assembly (230V)
21.	3C Pump Housing Assembly Complete Pump (115V) Complete Pump (230V)
22.	Water Temperature Sensor
23.	Lower Manifold (Outlet)
24.	Upper Manifold (Return)
25.	Nylon Strap Assembly
26.	Thermal Disc
27.	Heater - 800W (115V) Heater - 800W (230V)
28.	Complete Water Filter Assembly
29.	Evaporator Coil Assy.
30.	Plastic Elbow 3/4" x 3/4"
31.	Capillary Tubing
32.	Reservoir Gasket
33.	Bumper Guard Trim - 68"
34.	Beeper Assembly
35.	Flow Switch Assembly

FIGURE 6-3. PARTS LIST B

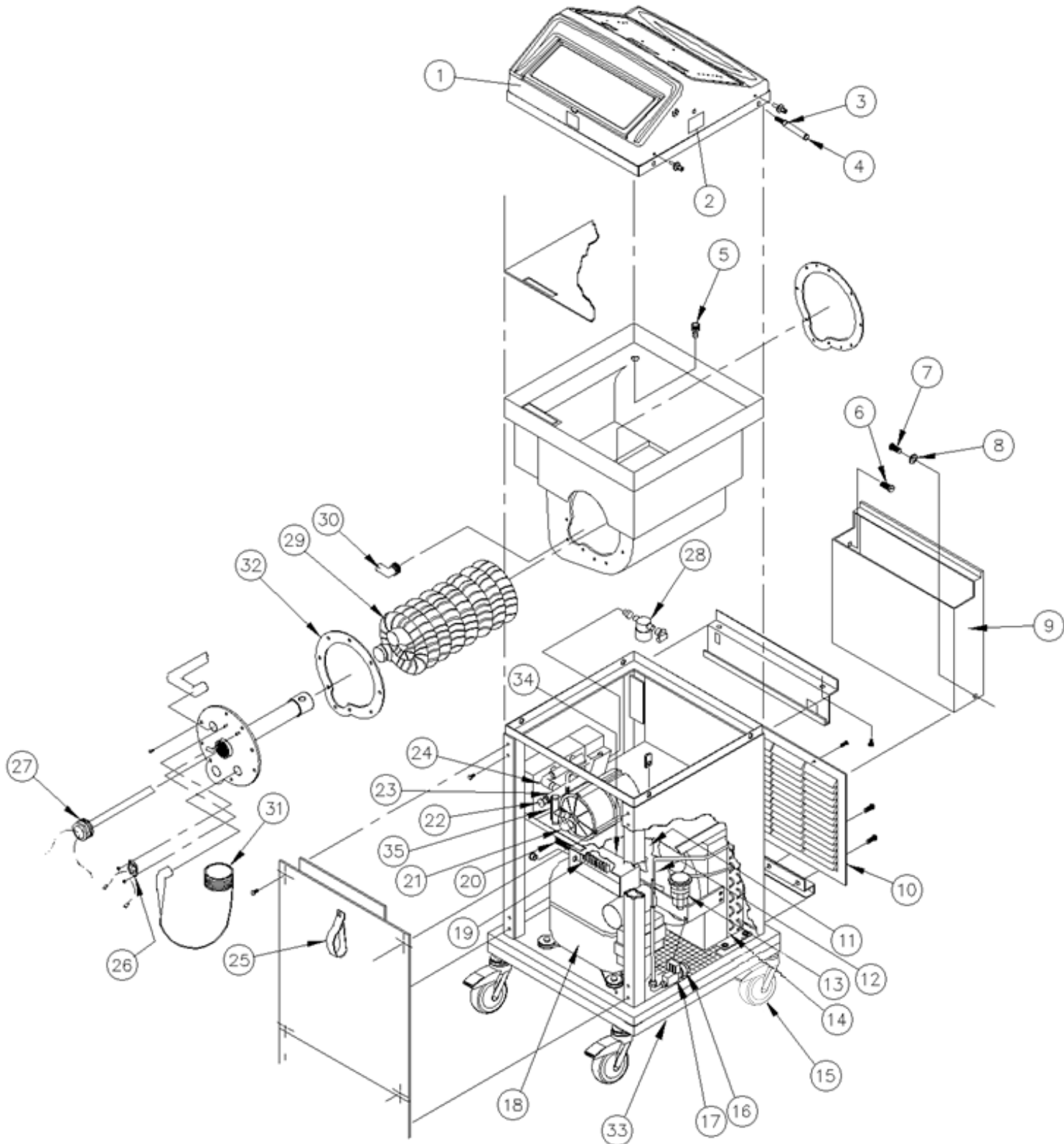
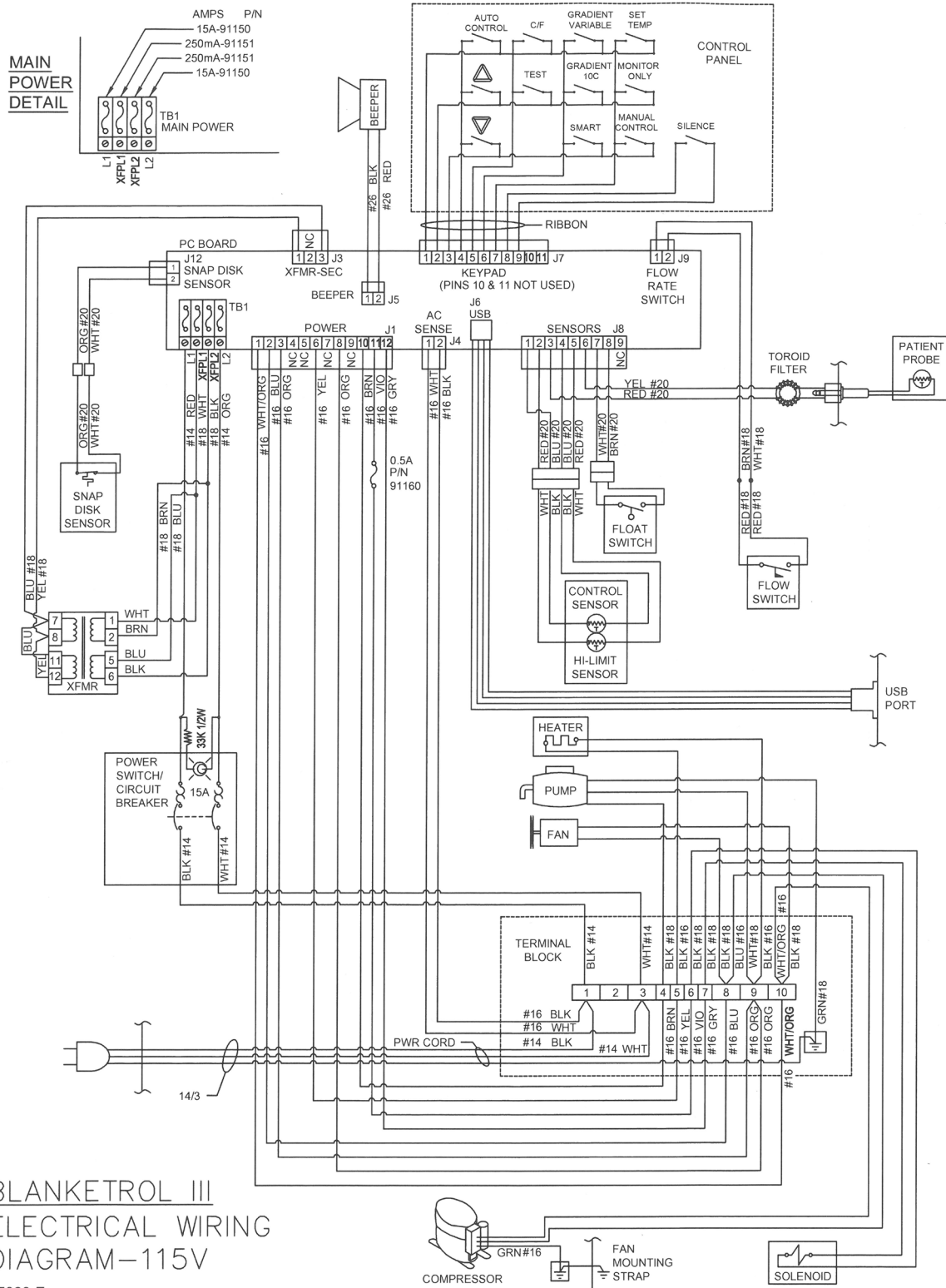

FIGURE 6-4. BLANKETROL III - INTERNAL EXPLODED - REAR VIEW



BLANKETROL III
ELECTRICAL WIRING
DIAGRAM-115V

55923-E

FIGURE 6-5. A. BLANKETROL III - ELECTRICAL WIRING DIAGRAM - 115 VOLT
Note: Beeper is located on the board for most devices built before 2nd quarter of 2012.

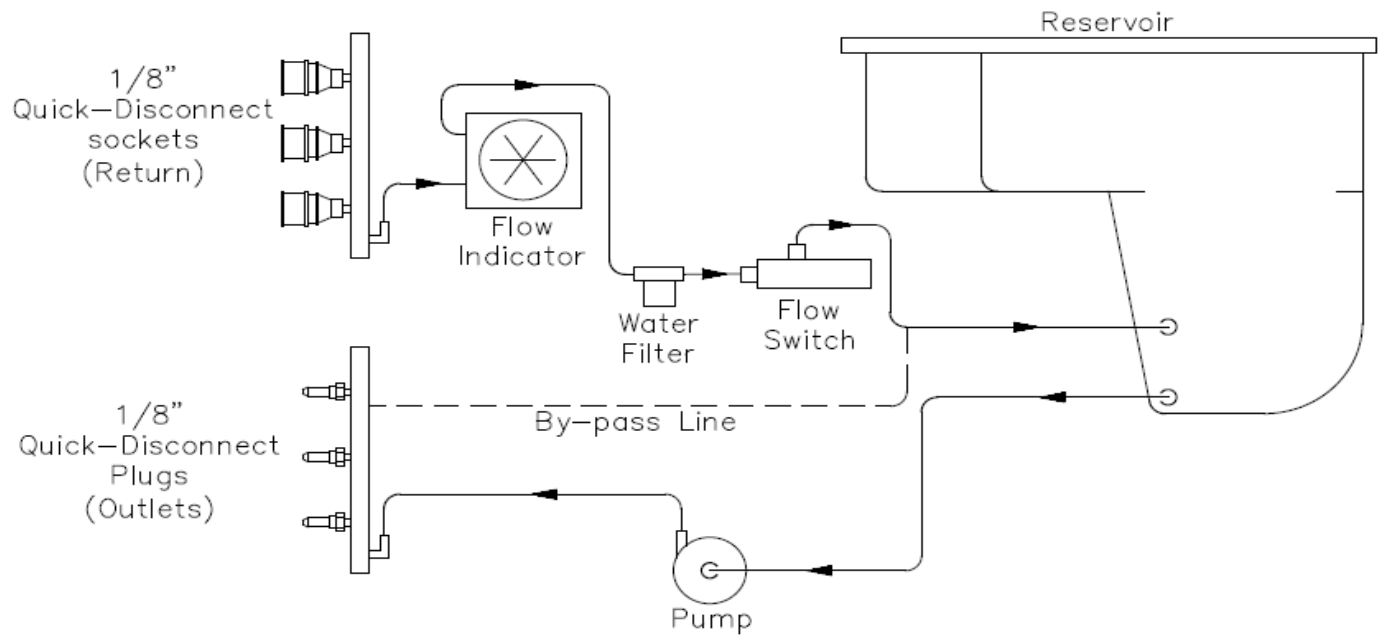

FIGURE 6-6. BLANKETROL III - WATER CIRCULATION DIAGRAM

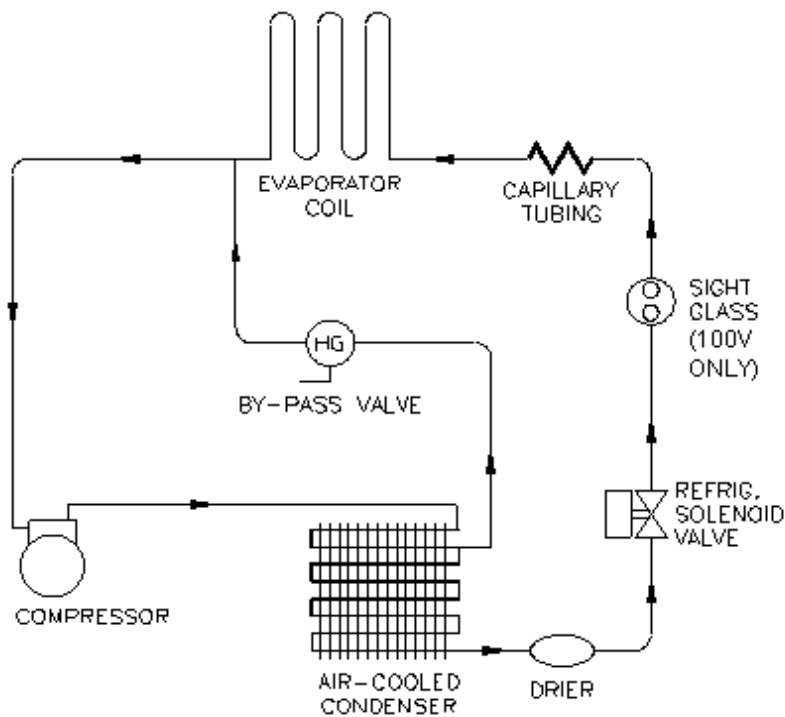

FIGURE 6-7. BLANKETROL III - REFRIGERATION FLOW DIAGRAM

TABLE 6-8. BLANKETROL III SYSTEM ACCESSORIES**WARNING**

- Use of accessories other than specified below **may result in increased electromagnetic emissions or decreased immunity to electromagnetic emissions** of the BLANKETROL III unit. This could affect BLANKETROL III's compatibility with other electrical equipment. Electromagnetic compatibility refers to electronic devices unintentionally affecting the operation of each other by emitting electromagnetic energy.

ACCESSORIES – BLANKETS

Blankets, Pads, and Hoses, Approved for Use with the BLANKETROL III are listed below.

MAXI-THERM Single-Patient Use Blankets

- 276 Adult or O.R. Table Size (24" x 60")
 274 Pediatric Size (22" x 30")
 273 Infant Size (12" x 18")
 Contents: 5/box, 4 boxes/case
 286 Reusable Connecting Hose (for GENTHERM Unit)

MAXI-THERM LITE Single-Patient Use Blankets

- 876 Adult Size (25" x 64")
 874 Pediatric Size (25" x 33")
 873 Infant Size (12.5" x 18")
 872 Pediatric Size (25" x 19")
 871 Pediatric Size (25" x 17.25")
 870 Localized Therapy (25" x 4")
 300 Staff Vest
 800 Patient Vest

PLASTIPAD Reusable Molded Plastic Blankets (Polyurethane)

- 196 Adult Size (24" x 60")
 195N Narrow Adult Size (20" x 60")
 194 Pediatric Size (22" x 30")
 193 Infant Size (12" x 18")
 193CPC Infant Size with CPC Connectors (12" x 18")
 186 9' Blanket Extension Hose with Couplings

Head Wrap Single-Patient Use Pad

- 600 Adult Head Wrap

KOOL KIT Single-Patient Use Convenience Kits

- 900 Kool Kit (Adult Head Wrap, Patient Vest and Lower Body Pad)
 910 Head Wrap Kit (Adult Head Wrap and Lower Body Pad)
 920 Patient Vest Kit (Patient Vest and Lower Body Pad)
 930 Large Kool Kit (Adult Head Wrap, Patient Vest and Full Body Pad)
 950 Kool Kit Neonate (Pediatric Pad and Esophageal/Rectal Temperature Probe)

Gelli-Roll Reusable Blankets

- 195P Adult Size (73.5" x 21.5")
 194P Pediatric Size (31.25" x 23.75")
 193P Infant Size (20" x 13")

Miscellaneous

- USB-127 Data Export Software
 TFRW Tri-Matic Tester

TEMPERATURE PROBES**Disposable Temperature Probes – Sterile – 400 Series:**

- 487M Skin Probe
 483M-9 Rectal/Esophageal Probe 9F
 4872MS Reusable Connecting Cable – Molex connection

**SECTION 7. SPECIFICATIONS AND CERTIFICATIONS OF THE
BLANKETROL III**



BLANKETROL III MODEL 233 FEATURES

PHYSICAL	SAFETY SYSTEM
<p>Dimensions: 17"W x 17"D x 37.5"H (43.18 cm.W x 43.18 cm. D x 95.25cm. H)</p> <p>Weight: Empty -131 lbs. (59.5kg) Shipping – 151 lbs. (68.5kg)</p> <p>Cabinet Construction: Powder coated steel with plastic top. Divided reservoir. Bottom air discharge. Built-in handle. Bumper guard. Storage Compartment. Four 4" non-conductive, 360° swivel-type locking casters.</p> <p>Ambient Temperature (during use): 15°C – 30°C (59°F – 86°F)</p> <p>Humidity (during use): 20% - 60%</p> <p>Maximum Contact Surface Temperature: 41°C (105.8°F)</p>	<p>Maximum High Control Setting: 42.0°C (107.6°F)</p> <p>High Limit Safety: 44.0°C ± 2.0°C (111.2°F ± 3.6°F)</p> <p>High Limit Secondary Back-up Safety: 44.0°C ± 2.0°C (111.2°F ± 3.6°F)</p> <p>Thermostatic Snap Disc: 46.0°C ± 2.0°C (114.8°F ± 3.6°F)</p> <p>Minimum Low Control Setting: 4.0°C (39.2°F)</p> <p>Low Limit Safety: 2.0°C ± 2.0°C (35.6°F ± 3.6°F)</p>
<p>THERMAL SYSTEM</p> <p>Compressor: 1/3 HP</p> <p>Heater: 800 Watts</p> <p>NOTE: Maximum expected heating capability approximately 3°C (5.4°F) per minute. Maximum expected cooling capability approximately 5.5°C (9.9°F) per minute. Time to heat from 23 ± 2°C to 37°C is approximately 12 minutes with a blanket attached.</p>	<p>Low Limit Secondary Back-up Safety: 2.0°C ± 2.0°C (35.6°F ± 3.6°F)</p> <p>Defective or Dislodged Probe Alarm: Audible & Visual</p> <p>Primary & Secondary High and Secondary Low Limit Failure Alarm: Audible & Visual</p>
<p>CIRCULATING SYSTEM</p> <p>Divided Compartment Reservoir, 2 gallon (7.5 liters) total capacity. Error proof, quick-disconnect fittings.</p>	<p>Low Water Alarm: Audible & Visual</p>
<p>ELECTRICAL SYSTEM</p> <p>Electrical Characteristics: 115V-127V±10%, 60Hz., 10.2 Amps 220V-230V±10%, 50Hz., 5.2 Amps</p> <p>Power Cord: 14/3 SJT (115V), Hospital grade plug Standard European Cord (230V)</p> <p>Leakage Current: Under 300 µa (115V) Under 500 µa (230V)</p> <p>Circuit Breaker: In Power Switch</p> <p>Mains Isolation: Two-Pole Mains Switch</p>	<p>Defective Water Temp Sensor: Audible & Visual</p> <p>Water Flow Indicator: Visual</p> <p>Low Flow Alarm: Audible & Visual</p> <p>Water Temperature Sensor Fault Alarm: Audible & Visual</p>

SPECIFICATIONS

**BLANKETROL III, Model 233
OPERATION AND TECHNICAL MANUAL**

BLANKETROL III MODEL 233 FEATURES (CONT.)

<p style="text-align: center;">CONTROL SYSTEM</p> <p>Microprocessor controlled, Lighted "OFF-ON" power switch, Digital LED Read Outs, Alarm Indications, and Mode Indications.</p> <p>Controller Range: Water Temp.: 4°C to 42°C (39.2°F to 107.6°F) Patient Temp.: 30°C to 40.0°C (86°F to 104°F)</p> <p>Display Accuracy: Water Temp. ± 0.5°C (± 1°F) (measured at 37°C) Patient Temp. ± 0.3°C (± .5°F)</p> <p>Display Range: Water Temp.: 0°C - 52°C (32°F - 126°F) Patient Temp.: MANUAL CONTROL: 10°C - 50.0°C (50°F - 122°F) AUTO MODES: 30.0°C - 43.5°C (86.0°F - 110.3°F) MONITOR ONLY: 10°C - 50.0°C (50°F - 122°F)</p> <p style="text-align: center;">Service Life</p> <p>The expected service life/ lifetime of the Blanketrol III, Model 233 unit is twelve (12) years from the date of manufacture provided the product is not subject to misuse, negligence, accident or abuse and under the conditions that the device is properly used as intended and serviced and maintained according to the Operation /Technical Manual provided with the device.</p>	<p style="text-align: center;">CONTROL SYSTEM (cont'd)</p> <p>Display Type: LED</p> <p>Temp. Settings: Water Temp.: 0.1°C (0.1°F) Patient Temp.: 0.1°C (0.1°F) Patient Probe ¼ inch receptacle: One Probe Type: 400 Series</p> <hr/> <p style="text-align: center;">ENVIROMENTAL CONDITIONS (during storage and transportation)</p> <p>Ambient Temperature (transportation and storage): -40°C - +50°C (-40°F - +122°F)</p> <p>Humidity (transportation and storage): 20% - 95%</p> <hr/> <p style="text-align: center;">WARRANTY</p> <p>2 yr. parts (Labor if returned to GENTHERM) Additional warranties available at time of purchase. Contact GENTHERM.</p>
<p style="text-align: center;">CLASSIFICATION</p> <p style="text-align: center;">Equipment is Class I.</p> <p style="text-align: center;">Equipment is Type BF.</p> <p style="text-align: center;">The blanket is a means of patient protection.</p> <div style="text-align: center;">   </div>	
<p style="text-align: center;">CERTIFICATIONS</p> <div style="display: flex; align-items: center; justify-content: center;">  <div style="text-align: left;"> <p>MODEL 233 MEDICAL ELECTRICAL EQUIPMENT WITH RESPECT TO ELECTRIC SHOCK, FIRE AND MECHANICAL HAZARDS ONLY IN ACCORDANCE WITH UL60601-1, IEC60601-1, IEC60601-2-35, ASTM F2196-02, IEC60601-1-2, AND CAN/CSA-C22.2 No. 601.1</p> </div> </div>	

The following tables are presented in fulfillment of the requirements of
IEC 60601-1-2

TABLE 7-1. GUIDANCE AND MANUFACTURER'S DECLARATION - ELECTROMAGNETIC EMISSIONS		
The BLANKETROL III, Model 233 is intended for use in the electromagnetic environment specified below. The customer or the user of the BLANKETROL III, Model 233 should assure that it is used in such an environment.		
Emissions tests	Compliance	Electromagnetic environment – guidance
RF emissions CISPR 11	Group 1	The BLANKETROL III, Model 233 uses RF energy only for its internal function. Therefore, its RF emissions are very low and are not likely to cause any interference in nearby electronic equipment.
RF emissions CISPR 11	Class A	The BLANKETROL III, Model 233 is suitable for use in all establishments other than domestic and those directly connected to the public low-voltage power supply network that supplies buildings used for domestic purposes.
Harmonic emissions IEC 61000-3-2	Class A	
Voltage fluctuations/ flicker emissions IEC 61000-3-3	Complies	

TABLE 7-2. GUIDANCE AND MANUFACTURER'S DECLARATION - ELECTROMAGNETIC IMMUNITY			
The BLANKETROL III, Model 233 is intended for use in the electromagnetic environment specified below. The customer or the user of the BLANKETROL III, Model 233 should assure that it is used in such an environment.			
Immunity test	IEC 60601 test level	Compliance level	Electromagnetic environment - guidance
Electrostatic discharge (ESD) IEC 61000-4-2	±6 kV contact ±8 kV air	±6 kV contact ±8 kV air	Floors should be wood, concrete or ceramic tile. If floors are covered with synthetic material, the relative humidity should be at least 30%.
Electrical fast transient/burst IEC 61000-4-4	±2 kV for power supply lines ±1 kV for input/output lines	±2 kV for power supply lines ±1 kV for input/output lines	Mains power quality should be that of a typical commercial or hospital environment.
Surge IEC 61000-4-5	±1 kV differential mode ±2 kV common mode	±1 kV differential mode ±2 kV common mode	Mains power quality should be that of a typical commercial or hospital environment.
Voltage dips, short interruptions and voltage variations on power supply input lines IEC 61000-4-11	<5% U_T (>95% dip in U_T) for 0,5 cycles 40% U_T (60% dip in U_T) for 5 cycles 70% U_T (30% dip in U_T) for 25 cycles <5% U_T (>95% dip in U_T) for 5 s	<5% U_T (>95% dip in U_T) for 0.5 cycle 40% U_T (60% dip in U_T) for 5 cycles 70% U_T (30% dip in U_T) for 25 cycles <5% U_T (>95% dip in U_T) for 5 s	Mains power quality should be that of a typical commercial or hospital environment. If the user of the BLANKETROL III, Model 233 requires continued operation during power mains interruptions, it is recommended that the BLANKETROL III, Model 233 be powered from an uninterruptible power supply or a battery.
Power frequency (50/60 Hz) magnetic field IEC 61000-4-8	3 A/m	3 A/m	Power frequency magnetic fields should be at levels characteristic of a typical location in a typical commercial or hospital environment.
Note: U_T is the a.c. mains voltage prior to application of the test level.			

TABLE 7-3. GUIDANCE AND MANUFACTURER'S DECLARATION - ELECTROMAGNETIC IMMUNITY			
The BLANKETROL III, Model 233 is intended for use in the electromagnetic environment specified below. The customer or the user of the BLANKETROL III, Model 233 should assure that it is used in such an environment.			
Immunity test	IEC 60601 test level	Compliance level	Electromagnetic environment - guidance
Conducted RF IEC 61000-4-6	3 Vrms 150 kHz to 80 MHz	3 Vrms	<p>Portable and mobile RF communications equipment should be used no closer to any part of the BLANKETROL III, Model 233, including cables, than the recommended separation distance calculated from the equation applicable to the frequency of the transmitter.</p> <p>Recommended separation distance</p> $d = 1,2\sqrt{P}$
Radiated RF IEC 61000-4-3	3 V/m 80 MHz to 2,5 GHz	3 V/m	$d = 1,2\sqrt{P} \quad 80 \text{ MHz to } 800 \text{ MHz}$ $d = 2,3\sqrt{P} \quad 800 \text{ MHz to } 2,5 \text{ GHz}$ <p>Where P is the maximum output power rating of the transmitter in watts (W) according to the transmitter manufacturer and d is the recommended separation distance in meters (m).</p> <p>Field strengths from fixed RF transmitters, as determined by an electromagnetic site survey,^a should be less than the compliance level in each frequency range.^b</p> <p>Interference may occur in the vicinity of equipment marked with the following symbol:</p> 
NOTE 1: At 80 MHz and 800 MHz, the higher frequency range applies.			
NOTE 2: These guidelines may not apply in all situations. Electromagnetic propagation is affected by absorption and reflection from structures, objects and people.			
^a Field strengths from fixed transmitters, such as base stations for radio (cellular/cordless) telephones and land mobile radios, amateur radio, AM and FM radio broadcast and TV broadcast cannot be predicated theoretically with accuracy. To assess the electromagnetic environment due to fixed RF transmitters, an electromagnetic site survey should be considered. If the measure field strength in the location in which the BLANKETROL III, Model 233 is used exceeds the applicable RF compliance level above, the BLANKETROL III, Model 233 should be observed to verify normal operation. If abnormal performance is observed, additional measures may be necessary, such as re-orienting or relocating the BLANKETROL III, Model 233.			
^b Over the frequency range 150 kHz to 80 MHz, field strengths should be less than 3 V/m.			

TABLE 7-4. RECOMMENDED SEPARATION DISTANCES BETWEEN PORTABLE AND MOBILE RF COMMUNICATIONS EQUIPMENT AND THE BLANKETROL III, MODEL 233			
The BLANKETROL III, Model 233 is intended for use in an electromagnetic environment in which radiated RF disturbances are controlled. The customer or the user of the BLANKETROL III, Model 233 can help prevent electromagnetic interference by maintaining a minimum distance between portable and mobile RF communications equipment (transmitters) and the BLANKETROL III, Model 233 as recommended below, according to the maximum output power of the communications equipment.			
Rated maximum output power of transmitter W	Separation distance according to frequency of transmitter m		
	150 kHz to 80 MHz $d = 1,2\sqrt{P}$	80 MHz to 800 MHz $d = 1,2\sqrt{P}$	800 MHz to 2,5 GHz $d = 2,3\sqrt{P}$
0,01	0,12	0,12	0,23
0,1	0,38	0,38	0,73
1	1,2	1,2	2,3
10	3,8	3,8	7,3
100	12	12	23
For transmitters rated at a maximum output power not listed above, the recommended separation distance d in meters (m) can be estimated using the equation applicable to the frequency of the transmitter, where P is the maximum output power rating of the transmitter in watts (W) according to the transmitter manufacturer.			
Note 1: At 80 MHz and 800 MHz, the separation distance for the higher frequency range applies.			
Note 2: These guidelines may not apply in all situations. Electromagnetic propagation is affected by absorption and reflection from structures, objects and people.			

Worldwide Order Placement

<p>Telephone.....1-800-989-7373 Fax.....1-513-772-9119 (U.S.) 24hr Clinical Support ...1-513-460-2038 Med Tech Support.....1-888-437-5608</p>
--

GENTHERM



Gentherm Medical, LLC
12011 Mosteller Road
Cincinnati, OH 45241

Toll Free: 1-800-989-7373

www.gentherm.com

Fax: (513) 772-9119