

HEMOTHERM[®]

OPERATION & TECHNICAL MANUAL MODEL 400CE DUAL RESERVOIR COOLER/HEATER



Gentherm Medical, LLC • 12011 Mosteller Road • Cincinnati, Ohio 45241, U.S.A.

www.gentherm.com

© Copyright 2020, Gentherm Medical, LLC All rights reserved.

Manual 56418 Rev. Z

SYMBOLS

	Consult instructions for use and/or manual before operating		Water Temperature
	Pump		AC Voltage
	Cool		Outlet
	Heat		Return
	Compressor		Drain
	Water Temp – Heat		Power Cord Holder
	Water Temp – Cool		Change Water Monthly
	Temperature Set		Clean Condenser Monthly
	Low Water		Clean Water Filter Quarterly
	Test Indicators		Equipotentiality
	Silence Alarm		Protective Earth
	High Limit		Danger; Risk of Electric Shock
	Low Limit		Power Fail
	High Heater		Disconnect Power Before Servicing
	Low Heater		Earth (Ground)
	Temperature Limit		Risk of Explosion: Do not use in the Presence of Flammable Anesthetics
	Operating Instructions or “Important/Caution Information”		Type BF Equipment
	Decreasing Temperature		Fill to Screen
	Increasing Temperature		Separate collection for electrical and electronic

HEMOTHERM[®]
MODEL 400CE
OPERATION & TECHNICAL MANUAL

Gentherm Medical, LLC reserves the right to make equipment changes and improvements which may not be reflected in this manual.

This document may not be reproduced in whole or in part without written permission from Gentherm Medical, LLC.

HEMOTHERM[®], MAXI-THERM[®], and MAXI-THERM[®] LITE are registered trademarks of GENTHERM MEDICAL, LLC, Cincinnati, Ohio USA.

⚠WARNING ⚠
A physician's order is required for use and the setting of equipment and blanket temperature. Check patient's temperature and skin condition of areas in contact with blanket; also, check blanket water temperature at least every 20 minutes, or as directed by physician. Pediatric patients, temperature-sensitive patients with vascular disease, surgical patients, diabetics and Raynaud's disease patients should be checked more frequently. Notify the physician promptly of any change in patient status in order to avoid serious injury or death.
The HEMOTHERM is to be operated by a professionally trained perfusionist – with a physician's order for use and the setting of equipment and blanket temperature.
Do not use the HEMOTHERM MODEL 400CE Blankets distal to arterial cross clamping. Non-observance can lead to thermal injury.
Thermal injury may occur if heating/cooling blankets are used with a patient with an ischemic limb.
Perfusionist must operate the HEMOTHERM when connected to extracorporeal circuit heat exchanger. Lack of proper monitoring may result in serious injury or death.
The operator of the unit regulates the desired fluid temperature. Frequent observation of the actual blood temperature and body temperature is required.
Perfusionist must monitor equipment continually during machine operation to ensure there are no "alarms or intervention" required. Lack of proper monitoring may result in serious injury or death.
No modification of this equipment is allowed without prior, written authorization from GENTHERM. Failure to do so may result in damage to the HEMOTHERM system and/or patient injury.
The method of temperature control provided by all cooler/heater units presents the danger of heating or cooling body tissues, particularly the skin and or blood, to a point where they are injured, i.e., burns or frostbite, respectively. Depending on the extent and severity of a burn, very serious and even fatal complications may arise.
Prevent excessive and/or prolonged tissue pressure and shearing forces, especially over bony prominences. Failure to do so may result in tissue injury.
Do not place additional heat sources between the patient and blanket. Skin damage may result.
Prep solutions have been reported to injure the skin when allowed to remain between patients and a water-circulating heating blanket during prolonged procedures. The area between the patient and the blanket should be kept dry to avoid injury to patient.
Proper sanitation procedures must be practiced and hygienic safety must be maintained, to prevent contamination. Contamination can affect patient's health, i.e. skin irritation/rash or sepsis and infection may result.
Upon receipt of the HEMOTHERM, the unit should be disinfected per the WATER SYSTEM CLEANING & DISINFECTION PROCEDURE. Additionally, any unit removed from storage should be disinfected. Failure to do so could result in patient and/or caregiver infection.
Do not use the HEMOTHERM system in the presence of flammable anesthetics. Risk of explosion can result.

⚠WARNING ⚠
Power interruption will cause the HEMOTHERM to revert to FILL MODE resulting in no therapy to the patient. Follow instructions for desired mode to resume operation. Failure to resume therapy could result in serious injury or death.
Any time water is found leaking into or around the unit, connecting hose, and/or blanket, turn the unit off, disconnect the power cord from its power source, and correct the problem before proceeding. Water leaks could lead to electric shock. Water leaks could present a slip and/or fall hazard.
Proper sanitation procedures should be followed including, but not limited to, the preventative maintenance described in this manual. Leaky blankets or hoses, as well as unapproved blankets or hoses should never be used. Water leaks present a risk of infection and should be handled accordingly.
Contaminated blankets or hoses could contaminate the unit. Reusable accessories should not be used. Reuse could result in patient and/or caregiver infection.
Exercise extreme caution if the unit is used for patients who are electrically susceptible (probe, catheter, or electrodes connected to the heart). Electrical Hazards may result.
Materials of good thermal conductivity, such as water, gel and similar substances on the blanket, with the HEMOTHERM not switched on may decrease the temperature of the patient.
Do not position unit near any objects that can generate a strong electrical/magnetic field. Unit has been investigated to be in compliance with IEC 60601-1-2. Potential electromagnetic interference may result.
The repair, calibration, and servicing of the HEMOTHERM should be performed by qualified Medical Equipment Service Technicians, Certified Biomedical Electronics Technicians, or Certified Clinical Engineers familiar with good repair practices for servicing medical devices, and in accordance with instructions contained in this manual. Improper repair can result in damage to the HEMOTHERM system and patient injury.
The HEMOTHERM must be serviced and/or preventive maintenance must be performed at specific intervals as outlined in the manual. Improper repair and inadequate maintenance can result in damage to the HEMOTHERM system and patient injury.
Always unplug the unit before accessing internal components during service. Failure to unplug the unit could result in electric shock.
Before returning the HEMOTHERM to patient use after repairs, the FIRST TIME SET-UP/SYSTEM TEST ROUTINE must always be performed. Improper repair and inadequate maintenance can result in damage to the HEMOTHERM system and/or patient injury.
Remove the HEMOTHERM from service if the outer casing or control panel is cracked or internal components are exposed. Contact with internal components could result in electric shock or thermal injury to the patient or operator. Additionally, the patient or operator could be exposed sharp edges.
Before performing any disassembly procedure, be sure the power switch is in the OFF/"O" position and the power cord is unplugged from the receptacle. Electrical Hazards may result.

⚠WARNING ⚠

Keep HEMOTHERM grille and condenser clean and free of debris and obstruction. Cool air is taken in through the grille and warm air is evenly expelled through the bottom of the unit. Both the air intake and outlet must be kept clear when the machine is in operation. **Blockage of the grille and condenser could result in the unit overheating which could render the unit unable to provide adequate therapy and excessive surface temperatures could cause injury to patient or operator. Keep unit, specifically the grille away from curtains or other obstructions.**

Do not use an adapter plug to by-pass the plug ground lug. **Electrical Hazards may result.**

Use only 20 Amp hospital grade receptacles or electric shock may result. (US only)

The HEMOTHERM unit has **UL/IEC 60601-1 Class I, type BF applied parts** and it should be noted that internal and external electrically isolated components must remain isolated before, during and after any maintenance or repair. **Improper maintenance or repair can result in patient injury or damage to the HEMOTHERM unit.**

To avoid the risk of electric shock, this equipment must only be connected to a supply mains with protective earth.

Inspect all blankets for mechanical damage before use. Do not use in proximity to sharp objects. **Blanket punctures can result in an increased risk of infection or electrical shock.**

The warming of transdermal medications (patches) **can increase drug delivery, resulting in possible injury to the patient.**

If a means is needed in restraining a patient either on or under a GENTHERM Hyper-Hypothermia Blanket or the Connecting Hose, the means should not block the fluid pathways of the HEMOTHERM unit. **Failure to do so may result in inadequate treatment.**

Immediately remove from service and clean & disinfect devices that show discoloration or cloudiness in the fluid lines/circuits. **Failure to do so could result in patient and/or caregiver infection.**

⚠ CAUTION ⚠

- Caution: Federal law restricts this device to sale by or on the order of a physician.
- Use only sterile water or water that has been passed through a filter of less than or equal to 0.22 microns. Do not use deionized water. Do not use alcohol. Alcohol may cause heat exchanger, blanket, and/or unit deterioration. Do not use tap water to rinse, fill, refill or top-off water tanks.
- Do not operate without water, to avoid damage to internal components.
- Do not overfill. Overfilling may result in overflow when the water in the blanket drains back into the system when the system is turned off.
- Be careful to not put any strain on any of the electrical cables connected to the circuit boards.
- Working with electronic boards, plugs, and cables requires delicate handling. Proper Electrostatic Discharge procedure should be followed during replacement of any electronic board.
- For safe handling and use of chemicals follow manufacturer guidelines.

TABLE OF CONTENTS**Page No.**

TECHNICAL HELP	12
AUTHORIZED EUROPEAN REPRESENTATIVE:	12
BEFORE YOU CALL FOR SERVICE... ..	12
IN-WARRANTY REPAIR AND PARTS	12
RECEIVING INSPECTION.....	12
IMPORTANT SAFETY INFORMATION.....	12
SHIPPING PARTS.....	13
WORLDWIDE ORDER PLACEMENT	13
SECTION 1. INTRODUCTION.....	14
1.1 GENERAL SAFETY PRECAUTIONS	14
1.2 INTENDED USE	15
1.3 DESCRIPTION, EXTERNAL FEATURES AND PRODUCT PARTS	15
1.4 FUNCTION OF HEMOTHERM MODEL 400CE COOLER/HEATER	21
1.5 COOLING SYSTEM	22
1.6 HEATING SYSTEM.....	22
1.7 WATER CIRCULATION SYSTEM	23
1.8 GENERAL OPERATION	24
1.9 REMOTE CONTROL OPTION	28
1.10 HEMOTHERM SYSTEM EQUIPMENT & ACCESSORIES	28
1.11 HEMOTHERM SYSTEM EQUIPMENT SPECIFICATIONS.....	29
1.12 ESSENTIAL PERFORMANCE TABLE.....	31
1.13 HEMOTHERM CLASSIFICATION AND CERTIFICATIONS.....	31
SECTION 2. OPERATING INSTRUCTIONS	35
2.1 INITIAL SET-UP	35
2.2 CONNECTION PROCEDURE.....	36
2.3 DISPOSAL OF WASTE PRODUCTS	36
2.4 SAFETY CONTROLS.....	37
SECTION 3. MAINTENANCE AND REPAIR.....	38
3.1 GENERAL	38
3.2 EXTERNAL CLEANING INSTRUCTIONS.....	38
3.3 FUSE REPLACEMENT	38
3.4 LOW LIMIT EQUIPMENT SAFETIES CHECK.....	38
3.5 HIGH LIMIT EQUIPMENT SAFETIES CHECK	40
3.6 TEMPERATURE ACCURACY CHECK	42
3.7 MAINTENANCE OF THE WATER RESERVOIRS.....	42
3.8 WATER SYSTEM CLEANING & DISINFECTION PROCEDURE	43
3.9 MAINTENANCE OF THE WATER FILTER.....	45
3.10 MAINTENANCE OF THE CONDENSER GRILLE	47
3.11 MAINTENANCE OF THE HYPER-HYPOTHERMIA BLANKETS	47
3.12 REPLACING THE HEATER	48
3.13 REPLACING PUMP HOUSING OR PUMP.....	48
3.14 REPLACING THE SENSOR.....	49
3.15 REPLACING THE POWER BOARD.....	50

3.16 REPLACING THE CONTROL PANEL..... 56

3.17 REPLACING THE WATER MANIFOLD..... 62

3.18 MEASURING LEAKAGE CURRENT..... 62

3.19 REMOVE FROM SERVICE ALARM (RFS) 62

3.20 REQUIRED QUARTERLY PREVENTIVE MAINTENANCE CHECKLIST..... 64

3.21 REQUIRED MONTHLY PREVENTIVE MAINTENANCE CHECKLIST 65

3.22 TROUBLESHOOTING GUIDE 66

3.23 TROUBLESHOOTING CONTROL OF THE SOLENOIDS..... 72

SECTION 4. PARTS INFORMATION 73

4.1 ORDERING INFORMATION FOR REPLACEMENT PARTS..... 73

4.2 RETURNING PARTS UNDER WARRANTY 73

4.3 IMPORTANT INFORMATION FOR SHIPPING RETURNED PARTS 74

4.4 EQUIPMENT, ACCESSORIES AND PARTS LIST ORDER INFORMATION..... 74

4.5 PARTS LIST FOR HEMOTHERM (FIGURE 4-1 THROUGH 4-6)..... 79

LIST OF ILLUSTRATIONS**Page No.**

FIGURE 1-1	UNIT FRONT PARTS VIEW	16
FIGURE 1-2	CONTROL PANEL - 115V UNIT	18
FIGURE 1-3	CONTROL PANEL - 115V REMOTE	18
FIGURE 1-4	CONTROL PANEL – 230V UNIT	19
FIGURE 1-5	CONTROL PANEL – 230V REMOTE	19
FIGURE 4-1	FRONT ASSEMBLIES AND PARTS	75
FIGURE 4-3	BASE ASSEMBLIES AND PARTS	77
FIGURE 4-4	DRAIN HOSE AND FLOW INDICATOR	77
FIGURE 4-5	115V HEMOTHERM REMOTE	78
FIGURE 4-7	WIRING DIAGRAM	83
FIGURE 4-8	CONTROL PCB DIAGRAM.....	84
FIGURE 4-9	WATER CIRCULATION DIAGRAM	85
FIGURE 4-10	REFRIGERATION FLOW DIAGRAM	86

TECHNICAL HELP

United States and Canada
Gentherm Medical, LLC
12011 Mosteller Road
Cincinnati, OH 45241

Telephone .	1-513-772-8810
Toll Free	1-800-989-7373
Fax	1-513-772-9119
Technical Support	1-888-437-5608
Clinical Support	1-513-460-2038

AUTHORIZED EUROPEAN REPRESENTATIVE:

EC REP CEpartner4U, BV
Esdoornlaan 13
3951 DB Maarn
The Netherlands
www.CEpartner4U.com

BEFORE YOU CALL FOR SERVICE...

To help us better serve you, please have the serial number of your HEMOTHERM unit ready when you call for parts or service. The serial number is located on the side panel of the unit along with the part number.

IN-WARRANTY REPAIR AND PARTS

All parts on your Hemotherm unit are covered by a one-year warranty. To return defective parts or units, first obtain a Returned Materials Authorization (RMA) number from our Medical Technical Service department. A Hemotherm shipping carton will be sent to you, if needed.

NOTE: There is a service charge for a replacement shipping carton.

RECEIVING INSPECTION

After unpacking the HEMOTHERM System, be sure to inspect the system for concealed damage. Retain all packing material and carefully describe or photograph any damage. Notify the carrier at once and ask for an inspection (in writing). Failure to do this within 15 days may result in loss of claim. Do not return the equipment to Gentherm. Call our Medical Technical Service department for further instructions. Refer to the section TECHNICAL HELP for phone numbers.

IMPORTANT SAFETY INFORMATION

Refer to this manual for instructions and caregiver information. Read and understand all precautionary information before using, prescribing, or servicing the HEMOTHERM unit.

In order to minimize risk of contamination, the unit should be disinfected per the WATER SYSTEM CLEANING & DISINFECTION PROCEDURE prior to its first use and at a minimum on a quarterly basis.

SHIPPING PARTS

Parts to be returned to the factory must be carefully packaged, especially the circuit boards. These boards should be cushioned in static safe packaging material to prevent damage from Electro Static Discharge (ESD).

NOTE: SHIPPING DAMAGE WILL BE THE RESPONSIBILITY OF THE SHIPPER. INSURE IF NECESSARY.

NOTE: IF CIRCUIT BOARDS ARE NOT SHIPPED IN STATIC SAFE PACKAGING, WARRANTY WILL BE VOID.

If shipping complete unit, to avoid freezing or damage to packaging, **the entire system must be drained before shipping**. See Section 3.7 MAINTENANCE OF THE WATER RESERVOIRS for proper procedures.

Worldwide Order Placement

United States and Canada

Telephone 1-513-772-8810
(U.S.) Toll Free 1-800-989-7373
Fax..... 1-513-772-9119

SECTION 1. INTRODUCTION

To provide the maximum patient safety during the use of the HEMOTHERM Model 400CE Dual Reservoir Cooler/Heater system, a thorough knowledge and understanding of the system, and its correct application and operating use are required. Each person who is responsible for use or direction of use of the system, such as physicians, perfusionists, technicians and operators must read and understand this operating manual and all precautions and warnings prior to use. It is recommended that this manual be reviewed at least semi-annually as a refresher for safe operation and application. For proper knowledge and understanding, in-service is available upon request.

All service associates, who interface with this equipment, must read and understand this **Operation & Technical Manual** in its entirety prior to maintaining or operating the equipment.

1.1 GENERAL SAFETY PRECAUTIONS

To provide the patient maximum safety during the use of the HEMOTHERM® Model 400CE Dual Reservoir Cooler/Heater system, a thorough knowledge and understanding, and the correct application and operating use of the system is required. Each person who is responsible for the use or the direction of use of the system, such as physicians, perfusionists, technicians and operators, must read and understand this operating manual, and all precautions and warnings prior to use. It is recommended that this manual be reviewed at least semi-annually as a refresher to safe operation and application.

The HEMOTHERM has internal self -diagnostics that could prevent the equipment from operating improperly. The most serious of these are the Remove from Service (RFS) alarms. The RFS alarms will require the equipment to be repaired immediately. They are indicated by an “EE” on the Heat side temperature display and a number on the Cool side temperature display. Too high of a temperature in the heat reservoir is also an RFS alarm and will be indicated by the appropriate red LED indicator. All RFS alarms will be announced by an audible alarm that cannot be muted.

High and low temperature limiting thermostats are preset at the factory and should perform satisfactorily for the life of the HEMOTHERM unit. Except for refrigeration component repairs, the repair and servicing of the HEMOTHERM unit requires no special tools. However, no attempt should be made to perform any of the repairs or service procedures outlined in this manual unless the proper skills and knowledge are possessed.

If water is found leaking into or around the HEMOTHERM unit prior to or during the operating procedure discussed here, immediately disconnect power to the unit and correct the malfunction before proceeding.

Before performing any disassembly procedure, press the power switch to the OFF/“O” position and unplug power cord from receptacle.

Exercise extreme caution if this equipment is used on electrically susceptible patients (probe, catheter or electrodes directly connected to the heart). Always test for current leakage before returning unit to service. Additional warnings are expressed at appropriate points in the manual.

See the Warnings and Cautions in the front of this manual.

1.2 INTENDED USE

The HEMOTHERM (Model 400CE) Dual Reservoir Cooler/Heater is used to lower, maintain, or raise the temperature of the water flowing through a Blood Oxygenator / Heat Exchanger that is used to cool or warm blood during cardiopulmonary bypass procedures lasting six hours or less. The Hemotherm Dual Reservoir Cooler/Heater may also be used with a hyper / hypothermia blanket under the patient to provide warming through conductive heat transfer.

The HEMOTHERM is capable of delivering temperature controlled water to blood heat exchanger(s) and one (1) blanket in the full range of controllability between 3°C - 42°C.

There are many variables that affect the heating or cooling of the patient in the extracorporeal circuit. Some of these include the patient's weight, blood flow, gas flow and oxygenator/heat exchangers. The HEMOTHERM has been designed to provide high water flow rates at low pressure for safe and highly efficient operation with a Blood oxygenator/heat exchanger.

1.3 DESCRIPTION, EXTERNAL FEATURES AND PRODUCT PARTS

The HEMOTHERM Model 400CE Dual Reservoir Cooler/Heater consists of a primary unit that has a water cooling system and a water heating system. These share a common pump, filter and distribution outlet connections. Each water cooling/heating system has its own reservoir, cooler/heater hardware, water level switch, temperature sensor and associated plumbing.

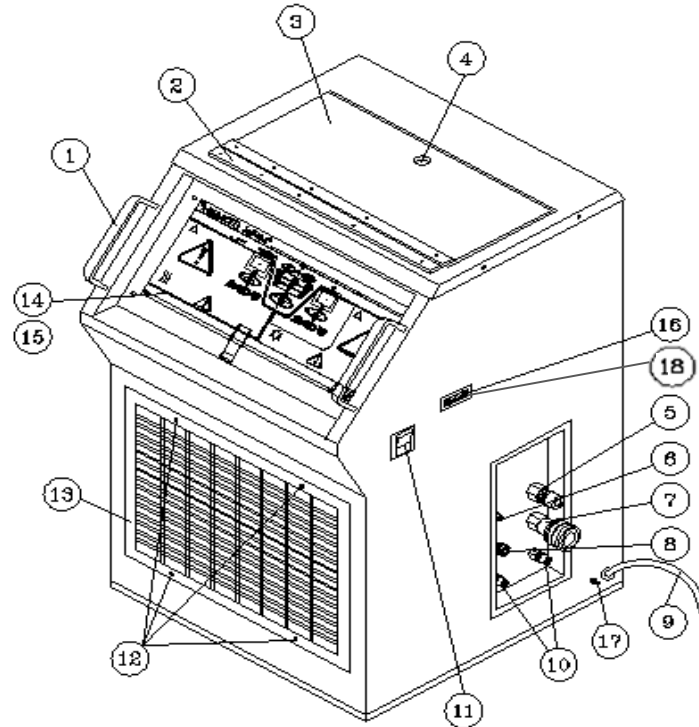

FIGURE 1-1, UNIT FRONT PARTS VIEW
Reference Figure 1-1, Unit Front Parts View

1. HANDLES - The handles permit the operator to grip the unit when moving.
2. CONTINUOUS HINGE – Provides durable smooth lid operation.
3. RESERVOIR LID – Covers the reservoir area.
4. LID HANDLE – Allows the user to easily grip the lid for opening.
5. 1/2 INCH QUICK-CONNECT PLUG OUTLET – This fitting is for the connection of the tubing that is connected to the user provided heat exchanger.
6. 1/8 INCH QUICK-CONNECT PLUG OUTLET – This fitting is for the connection of the tubing that is connected to the user provided optional blanket.
7. 1/2 INCH QUICK-CONNECT SOCKET INLET – This fitting is for the connection of the tubing that is returned from the user provided heat exchanger.
8. 1/8 INCH QUICK-CONNECT SOCKET INLET – This fitting is for the connection of the tubing that is returned from the user provided optional blanket.
9. MAINS POWER CORD – For connection to the mains power receptacle.
10. 1/4 INCH QUICK-CONNECT DRAIN OUTLETS – The left outlet drains the cool reservoir. The right outlet drains the heat reservoir.

11. MAINS POWER SWITCH – Controls power to the entire unit and the remote control (if it is connected). Includes integrated circuit breaker for unit over-current protection.
12. GRILLE SCREWS – Allow easy access to clean the front of the condenser.
13. GRILLE – Provides air flow and protection to the condenser.
14. CONTROL PANEL – Main control interface for all unit operations.
15. CONTROL BOARD (behind control panel) – Electronics package with precision dual microprocessor control and redundant water temperature safeties.
16. REMOTE CONTROL PORT – For connection of extension cables that lead to the Remote Control, Model 414CE. One or two 25 foot cables may be used for a maximum reach of 50 feet.
17. EQUIPOTENTIALITY GROUND – Provided to allow connection to the patient area common equipotential ground system.
18. REMOTE PORT COVER

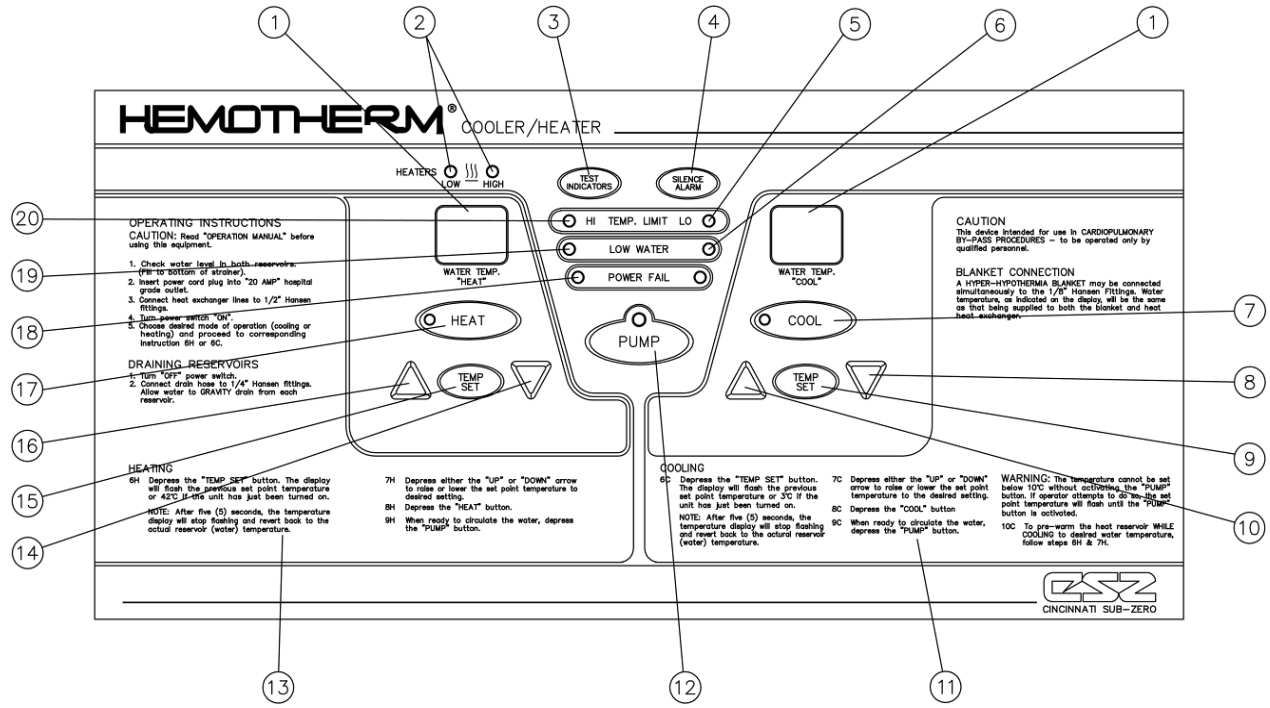

FIGURE 1-2, CONTROL PANEL - 115V UNIT

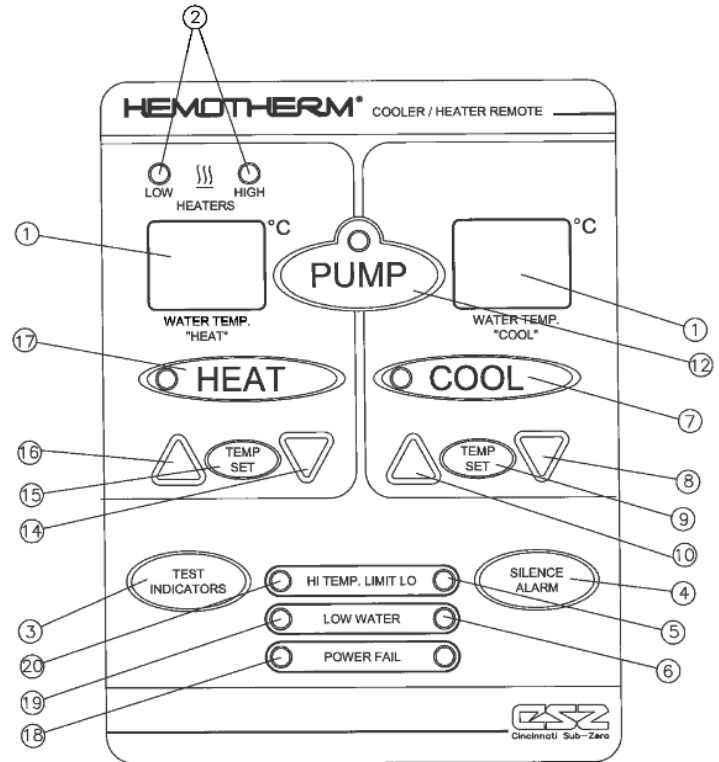

FIGURE 1-3, CONTROL PANEL - 115V REMOTE

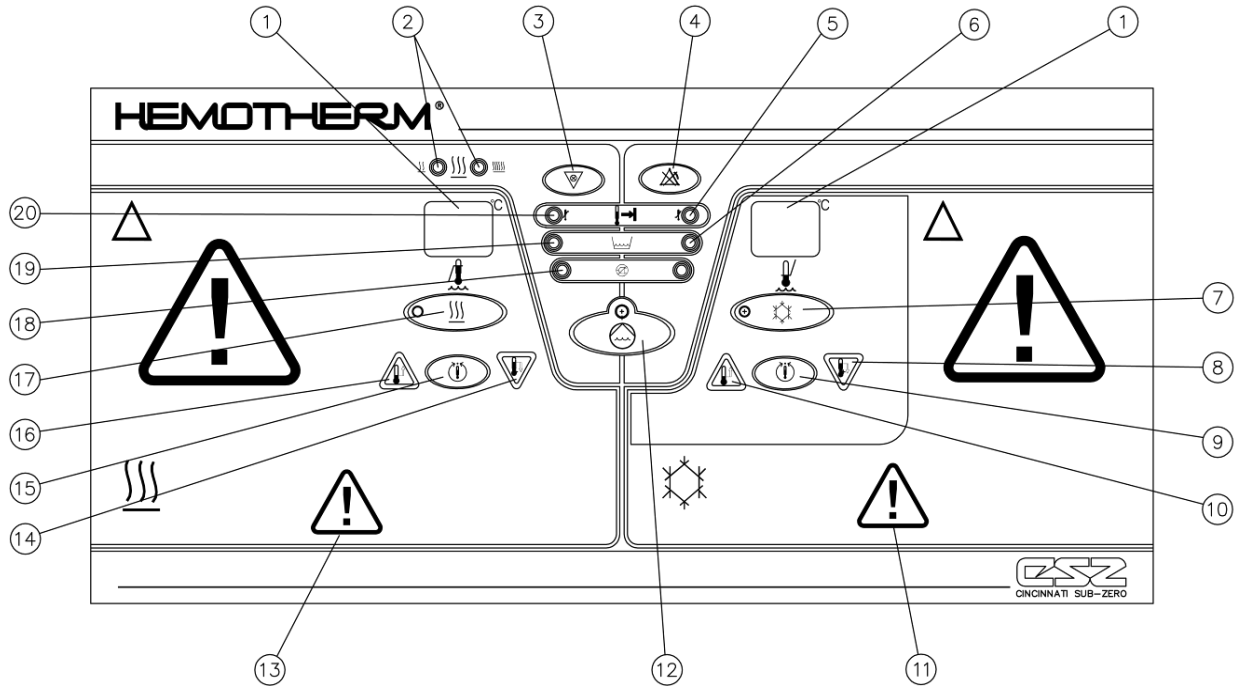

FIGURE 1-4, CONTROL PANEL – 230V UNIT

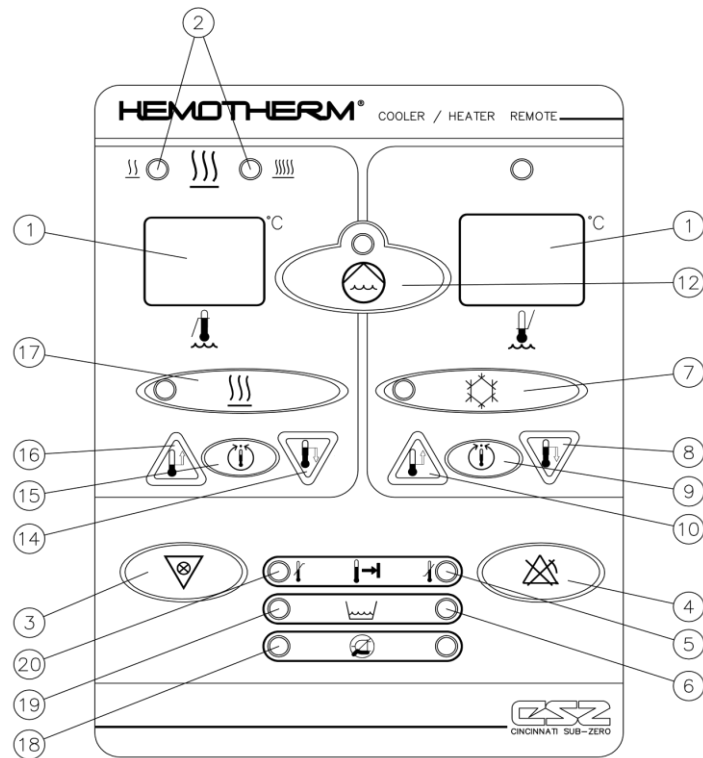

FIGURE 1-5, CONTROL PANEL – 230V REMOTE

Reference Figures 1-2, 1-3, 1-4 & 1-5, Control Panel Views

1. TEMPERATURE DISPLAY WINDOWS – Left side indicates heat reservoir temperature. Right side indicates cool reservoir temperature. This display is also used to display the set point temperature when the control is in the temp set mode.
2. HEATER STATUS LIGHTS – When illuminated these indicate that the controller is signaling the heaters to be on. These lights will not indicate a heater that is malfunctioning or inoperative due to a burned out heater element or wire break.
3. TEST INDICATORS BUTTON – When pressed this button will turn on all of the control panel indicators and test the audible alarm.
4. SILENCE ALARM BUTTON – When pressed this button will temporarily silence the alarm if it is not a Remove from Service (RFS) issue.
5. LOW TEMP LIMIT LIGHT – When illuminated the cool reservoir temperature is lower than should be allowed by the safety limits.
6. COOL LOW WATER LIGHT – When illuminated water needs to be added to the cool reservoir. Use only sterile water or water that has been passed through a filter of less than or equal to 0.22 microns.
7. COOL MODE BUTTON / LIGHT – When pressed this button along with the pump button will start the cool reservoir conditioning to obtain the indicated set point temperature. The light will be illuminated when the unit is in cool mode.
8. COOL DECREMENT BUTTON – When pressed this button will decrease the temperature set point indicated on the cool temperature display.
9. COOL TEMP SET BUTTON – When pressed this button will indicate the desired set point temperature of the cool reservoir on the cool temperature display.
10. COOL INCREMENT BUTTON – When pressed this button will increase the temperature set point indicated on the cool temperature display.
11. COOL INSTRUCTIONS – Abbreviated instructions on how to adjust and set the cool reservoir temperature. To completely understand the operation of the unit, consult appropriate sections in this manual.
12. PUMP BUTTON – When pressed this button will turn on the pump that circulates water in and out of the unit. This button must be pushed after the cool button is pushed if you want to cool the water in the cool reservoir or for unit preconditioning. The pump does not need to be on to allow the heaters to come on. The light will be illuminated when the controller is signaling the pump to operate.

13. HEAT INSTRUCTIONS – Abbreviated instructions on how to adjust and set the heat reservoir temperature. To completely understand the operation of the unit, consult appropriate sections in this manual.
14. HEAT DECREMENT BUTTON – When pressed this button will decrease the temperature set point indicated on the heat temperature display.
15. HEAT TEMP SET BUTTON – When pressed this button will indicate the desired set point temperature of the heat reservoir on the heat temperature display.
16. HEAT INCREMENT BUTTON – When pressed this button will increase the temperature set point indicated on the heat temperature display.
17. HEAT MODE BUTTON / LIGHT – When pressed, this button will put the unit in heat mode. It will start the heat reservoir conditioning to obtain the indicated set point temperature. Unlike the cool mode button this button will allow the heaters to turn on independent of the pump operation. The light will be illuminated when the unit is in heat mode.
18. POWER FAIL LIGHTS – When illuminated these lights will flash alternately to indicate that during operation, the unit has become unplugged or otherwise lost power and the power switch was in the on position.
19. HEAT LOW WATER LIGHT – When illuminated water needs to be added to the heat reservoir. Use only sterile water or water that has been passed through a filter of less than or equal to 0.22 microns.
20. HEAT HIGH TEMP LIMIT LIGHT – When illuminated the heat reservoir temperature is higher than should be allowed by the safety limits.

1.4 FUNCTION OF HEMOTHERM MODEL 400CE COOLER/HEATER

The HEMOTHERM Model 400CE Cooler/Heater is used to lower/raise the blood temperature and/or maintain blood temperature, as required, through conductive heat transfer of conditioned water. The conductive heat transfer is accomplished through a blood oxygenator/heat exchanger unit, along with the use of a blanket under the patient for the re-warming phase, if desired. The complete system usually comprises the HEMOTHERM Cooler/Heater unit and disposable blanket on the O. R. Table-Adult, Pediatric, or Infant size. Available blankets are: the disposable MAXI-THERM[®], and MAXI-THERM[®] LITE blankets.

There is also an optional Remote Control, Model 414CE available that will allow the unit to be controlled from 25 or 50 feet away.

1.5 COOLING SYSTEM

The HEMOTHERM 400CE cooling system consists of:

1. Mechanical refrigeration system
2. Cool water reservoir
3. Water re-circulation pump
4. Power & control system
5. Low temperature safeties
6. Low water level cut off safety
7. Non-conductive electrical isolation refrigerant hoses

With a capacity to lower the water temperature, a reduction of blood temperature is produced. It is important to remember that there is no direct relationship between this and the rate of change in the blood temperature. The re-circulation pump and water flow circuitry have been designed for high flow rate to maximize the blood-to-water heat transfer efficiency.

The cooling system's temperature controller allows the equipment operator to set the temperature range from +3°C to +32°C. Independent Low Limit Equipment Safeties on the control board provides low limit equipment protection and is factory preset at 2°C.

This is a redundant safety system in that there are two independent Low Limit Equipment Safeties preset at 2°C.

WARNING

The HEMOTHERM unit has **UL/IEC 60601-1 Class I, type BF applied parts** internal and external electrically isolated components must remain isolated before, during and after any maintenance or repair. **Improper maintenance or repair can result in patient injury or damage to the HEMOTHERM unit.**

1.6 HEATING SYSTEM

The GENTHERM HEMOTHERM heating system consists of:

1. Dual element Heater
2. Heat water reservoir
3. Water recirculation pump
4. Power & control system
5. High temperature safeties
6. Low water level cut off safety

The 115V / 1500 watt dual element heater has 1250 high and 250 low watt elements. The 230V / 1750 watt dual element heater has 1500 high and 250 low watt elements.

When in cool mode, the low wattage heater will pre-warm the water to the desired temperature set point for that reservoir. While in the heat mode, the water is heated with both high and low wattage elements. It is important to remember that there is no direct relationship between the temperature in the reservoirs and the rate of change in the blood temperature.

An over temperature limit (OTL) alarm automatically monitors the actual heat side reservoir temperature and compares it to the heat side set point. If the actual display temperature increases above the set point by 1°C or more for longer than two (2) minutes the high temperature limit LED on the front panel will flash and the alarm will sound a short beep. Once the temperatures are within 1°C the alarm will clear.

If the controller should happen to fail at the 42°C set point, the HIGH TEMP. LIMIT light on the control panel will illuminate and the alarm will sound at 44°C. The primary high temperature safety is designed to automatically shut off the heaters at 44°C. The heating system will come back on after approximately a 1°C temperature drop below the heat set point.

This is a redundant system in that there is a secondary high temperature safety preset at 46°C. If the primary high temperature safety should happen to fail at 44°C, the HIGH TEMP. LIMIT light on the control panel will illuminate and alarm will sound at 46°C and the heaters will turn off automatically. If this should occur, the system should be inspected by the hospital's maintenance or engineering department. This is a Remove from Service (RFS) alarm.

1.7 WATER CIRCULATION SYSTEM

The HEMOTHERM 400CE circulation system consists of:

1. Two water reservoirs
 - Cool Reservoir - (8 qts. - 7.6 liters)
 - Heat Reservoir - (6 qts. - 5.7 liters)
2. One recirculation pump
3. Four water flow control solenoid valves
4. One water filter
5. Six quick-connect fittings
6. Interconnecting water piping

Selection of the heat or cool mode determines which water flow circuit is used.

HEAT MODE: Pump draws water from the heat reservoir and circulates it through the water filter to the quick-connect fittings connected to the device in use (blood oxygenator/heat exchanger and/or blanket). Returning water flows back into the same heat reservoir.

COOL MODE: Pump draws water from the cool reservoir and circulates it through the water filter to the quick-connect fittings connected to the external device(s). Returning water flows back into the same cool reservoir.

⚠ CAUTION ⚠

Use only sterile water or water that has been passed through a filter of less than or equal to 0.22 microns. Do not use deionized water. Do not use alcohol. Alcohol may cause heat exchanger, blanket, and/or unit deterioration. Do not use tap water to rinse, fill, refill or top-off water tanks.

Flow rate capacity is as follows:

For 115VAC units through 1/2" quick-connect fittings: approximately 3.4 GPM with a short hose loop and flow meter attached to the fittings.
(13 liters/minute).*

For 230VAC units through 1/2" quick-connect fittings: approximately 3.0 GPM with a short hose loop and flow meter attached to the fittings.
(11 liters/minute).*

* Actual flow rate will vary depending upon brand and model number of heat exchanger used and also upon length and type of tubing leading to and from heat exchanger.

1.8 GENERAL OPERATION

1. Collect all Supplies and Equipment:
 - A. HEMOTHERM Cooler/Heater unit: Include connecting hoses to the extracorporeal circuit heat exchanger making sure that all connections are tight and secure.
 - B. Extracorporeal circuit heat exchanger: Make sure that there are no leaks.
 - C. Hyper-Hypothermia blanket: Make sure that there are no leaks.

⚠ WARNING ⚠

Upon receipt of the HEMOTHERM, the unit should be disinfected per the WATER SYSTEM CLEANING & DISINFECTION PROCEDURE. Additionally, any unit removed from storage should be disinfected. **Failure to do so could result in patient and/or caregiver infection.**

Contaminated blankets or hoses could contaminate the unit. Reusable accessories should not be used. **Reuse could result in patient and/or caregiver infection.**

2. Place HEMOTHERM unit in O.R. suite as close to the heat exchanger as possible and verify tight and secure connections to both the HEMOTHERM and extracorporeal circuit heat exchanger.
3. Read the operating instructions on the control panel and in this manual. Familiarize yourself with the name and location of all features and controls shown in this manual.
4. Check the level of the water in both fluid reservoirs to make certain they are filled to where water can be seen in bottom of the strainer. (Heat reservoir holds 6 qts. (5.7 liters) and the Cool reservoir holds 8 qts. (7.6 liters). It is necessary to add water after each use to replace water left in disposable heat exchanger and Hyper-Hypothermia blanket. Use only sterile water or water that has been passed through a filter of less than or equal to 0.22 microns.
5. Make sure the power switch is in the "OFF" position.
6. Inspect the power cord plug for bent or missing prongs. Insert the plug into a properly grounded, securely mounted receptacle. Grounding reliability can only be achieved when connected to an equivalent hospital grade receptacle. Do not bypass the third or grounding prong. An electrical hazard may result if it is bypassed, removed, or otherwise rendered useless.
7. Lay the Hyper-Hypothermia blanket flat on the O.R. table with hose attachment coming off the table as close as possible to where the HEMOTHERM unit will be placed.
8. Test-Indicators: Energize and De-energize all display segments and all LED's. Press the power switch to the "ON" position.

NOTE: The HEMOTHERM unit will go through a short self-calibration procedure with both displays blank and then through a fill mode for approximately forty-five seconds. The displays will show FI on the Heat side and LL on the Cool side spelling out FILL. This allows the unit to calibrate and prime the pump automatically.

- A. Press "HEAT" or "COOL" for desired mode of operation. (Flashing Temperature is set point; Non-Flashing is actual reservoir temperature). Preset temperatures are 3°C -cooling; 42°C -heating.
- B. Select Cool - cool display will flash when below 10°C until pump switch is activated. Then it will display actual water temperature and the compressor will start up.
- C. If you wish to change the setting, press the "Temp Set" switch. The display will flash the previous set point temperature or 3°C if the unit has just been turned on.

NOTE: You have five seconds to press one of the arrows or the temperature readout will return to the actual reservoir temperature. Press either the "up" or "down" arrow to raise or lower the set point temperature to the desired setting.

- D. Press the "Cool" switch. When ready to circulate the water, press the pump switch.

⚠ NOTE ⚠

The temperature cannot be set below 10°C without activating the "Pump" switch. If the operator attempts to do so, the set point temperature will flash until the "Pump" switch is activated. Then it will display the actual temperature and the compressor will activate.

- E. The HEMOTHERM will automatically pre-warm the heat reservoir while cooling to the desired water temperature. To adjust the pre-warm set point, press the "Temp Set" switch. The display will flash the previous set point temperature or 42°C if the unit has just been turned on.

NOTE: You have five seconds to press one of the arrows or the temperature readout will return to the actual reservoir temperature. Press either the "up" or "down" arrow to raise or lower the set point temperature to the desired setting.

NOTE: When the compressor cycles off, full heat comes on until the temperature of the heat reservoir is within 1°C of the set point. If the compressor cycles back on, only the low wattage heater element remains on.

- F. The unit will not cool below 10°C unless the pump is activated.

- G. Select the "HEAT" switch. Press the "Temp Set" switch. The display will flash the previous set point temperature or 42°C if the unit has just been turned on.

NOTE: You have five seconds to press one of the arrows or the temperature readout will return to the actual reservoir temperature. Press either the "up" or "down" arrow to raise or lower the desired setting. Press the heat switch.

- H. When ready to circulate the water, press the "Pump" switch.

9. After the cool water is preconditioned, proceed to connect your heat exchanger to the 1/2" quick-connect fittings.

NOTE: You may want to turn off the pump or the flow indicator shut-off valve first if you choose not to circulate cool water through the heat exchanger at this time.

10. Check physician's instructions to determine the desired cool and/or heat set point temperatures.
11. At this point, you may choose to maintain normal body temperature or you may choose to cool the blood.

12. Maintain normothermia by setting the desired temperature, pressing the heat mode switch, and making sure the pump is on. The "HEAT" temperature displayed is the water temperature circulating through the heat exchanger and the Hyper-Hypothermia blanket (if you choose to use a blanket).

NOTE: The precision dual microprocessor controller will supply the appropriate amount of wattage to the heater in order to maintain temperature.

13. Cool the blood by setting the desired fluid temperature. Using the cool mode "temp set", you may choose 3°C for better efficiency. The "COOL" temperature displayed is the fluid temperature circulating through the heat exchanger.

NOTE: The compressor will cycle on and off to maintain the set point temperature.

14. Maintain final hypothermia temperature by resetting the Cool set point temperature to 10°C and turning off the pump when you reach the hypothermia temperature desired. If the temperature should tend to rise, reactivate the pump allowing the cool water to circulate through the heat exchanger and as a result bring the blood temperature down again.
15. Preset your hot water temperature to the desired initial re-warming temperature.
16. The units will re-warm by activating the "HEAT" switch. The Hemotherm will receive the maximum wattage of heat to raise the hot water fluid temperature to the set point temperature. At this point, if desired, connect your Hyper-Hypothermia blanket to the 1/8" quick-connect fittings of the HEMOTHERM unit to maximize re-warming efficiency.

⚠ NOTE ⚠

If you happen to overshoot your desired "HEAT" water temperature, you may push the "COOL" switch for five to ten seconds allowing the water in the water lines and heat exchanger to empty into the "COOL" water reservoir. Switching back to the "HEAT" mode will allow cool water in the water lines and heat exchanger to be mixed into the "HEAT" water, in turn cooling the temperature of that water a few degrees (1°- 4°C) depending on the difference in temperature between the two reservoirs. The same can be done if you overshoot your desired cool water temperature.

- To discontinue operation, simply turn off the power switch and disconnect all lines leading to the heat exchanger and/or blanket from the HEMOTHERM unit.

1.9 REMOTE CONTROL OPTION

⚠ NOTE ⚠

The Model 400CE will only work with the Model 414CE Remote control and cables and is not compatible with the HEMOTHERM Model 400M or Model 400MR units.

All HEMOTHERM units are equipped with a remote control port. The remote control port connection is located on the right side of the unit, near the power switch/circuit breaker. If the remote control option is purchased, the "assembly" will include a mating 25 foot cable, the remote control unit, and a mounting clamp.

To install the remote control option, first turn the HEMOTHERM unit power switch off. Mount the remote control in a convenient place utilizing the universal mounting clamp provided. Connect the cable between the two devices and secure in place by tightening the screws attached to the cable housing. The remote control will operate the same as the control panel located on the HEMOTHERM main unit.

1.10 HEMOTHERM SYSTEM EQUIPMENT & ACCESSORIES

<u>Cat. No.</u>	<u>HEMOTHERM Equipment</u>
400CE	HEMOTHERM Dual Reservoir Cooler/Heater
414CE	Remote Control (includes UMC-1 and 25 ft. cable)
420	Flow Indicator with Shutoff Valve Assembly
UMC-1	Universal Mounting Clamp

MAXI-THERM® Single-Patient Use Blankets (Vinyl)

276	Adult/O. R. Table Size (24" x 60")
274	Pediatric Size (22" x 30")
273	Infant Size (12" x 18")
286	9' Connecting Hose (Extra Length Hoses Available Upon Request)

MAXI-THERM® LITE Single-Patient Use Blankets

876	Adult/O.R. Table Size (25" x 64")
874	Pediatric Size (25" x 33")
873	Infant Size (13" x 18")
286	9' Connecting Hose (Extra Length Hoses Available Upon Request)

1.11 HEMOTHERM SYSTEM EQUIPMENT SPECIFICATIONS

<p style="text-align: center;"><u>PHYSICAL</u></p> <ul style="list-style-type: none"> • Dimensions: 22" W x 22" D x 32" H (56cm W x 56cm D x 81cm H) • Floor space consumed: 484 in². (3,123 cm².) • Weight: 200 lbs. (90.7kg.) • Cabinet construction: 16 gauge steel • Warm air flow: bottom (downward) <p style="text-align: center;"><u>CIRCULATING SYSTEM</u></p> <p><u>Reservoir Capacity:</u> Cool - 8 qts. (7.6 liters) Heat - 6 qts. (5.7 liters)</p> <p>Reservoir Fluid: Use only sterile water or water that has been passed through a filter of less than or equal to 0.22 microns. Reservoir Opening: Fill-able from the top Reservoir Construction: Plastic</p> <p><u>Flow Rate:</u></p> <ul style="list-style-type: none"> • 11 Liters/Minute (3.0 GPM) at 230VAC for 1/2" quick connect fittings • 13 Liters/Minute (3.4 GPM) at 115VAC for 1/2" quick connect fittings <p><u>Maximum Pressure:</u> 12.5 PSI - Heat Exchanger and Blanket</p> <p><u>Connections:</u></p> <ul style="list-style-type: none"> • 1 Set 1/2" quick connect fittings for Heat Exchanger • 1 Set 1/8" quick connect fittings for Blanket • 1 Set 1/4" quick connect fittings for draining (on unit) • 1 Additional set 1/2" quick connect fittings included for tubing 	<p style="text-align: center;"><u>ELECTRICAL</u></p> <p>Electrical Characteristics:</p> <ul style="list-style-type: none"> • 115VAC, 50/60HZ, 16 Amps • 230VAC, 50/60HZ, 9 Amps <p>Outlets Required:</p> <ul style="list-style-type: none"> • 115VAC - 20 Amps, AC grounded hospital grade plug • 230VAC - 15 Amps, AC grounded with European plug <p>Circuit Breaker Rating: In power switch</p> <ul style="list-style-type: none"> • 115VAC, 20 Amps • 230VAC, 15 Amps <p>Mains Supply Isolation</p> <ul style="list-style-type: none"> • Two-Pole Mains Power Switch <p style="text-align: center;"><u>SAFETY</u></p> <p>Second Hi Limit Safety: 46°C ± 0.5°C Primary Hi Limit Safety: 44°C ± 0.5°C Low Limit Safety: 2°C ± 0.5°C</p> <p style="text-align: center;"><u>ENVIROMENTAL CONDITIONS</u></p> <p>Temperature Range (transportation and storage): -40°C – 50°C (-40°F – 122°F)</p> <p>Humidity (transportation and storage): 20% – 95%</p>
---	--

<p style="text-align: center;"><u>COOLING SYSTEM</u></p> <p>Compressor: ½ HP oversize</p> <p>Fluid Cooling Range: 32°C to 3°C</p>	<p style="text-align: center;"><u>CONTROL SYSTEM</u></p> <p>Fluid Temp Control Range: 3°C to 42°C</p> <p>Fluid Temp Control Accuracy:</p> <ul style="list-style-type: none"> • Set-points 3°C-5°C and 40°C-42°C: ±0.5°C • Set-points 5°C-40°C: ± 1.0°C <p>Fluid Temp Setting: 1°C Resolution</p>
<p style="text-align: center;"><u>HEATING SYSTEM</u></p> <p>Power Rating:</p> <p><u>115 VAC</u>: 1500 Watts of Heat</p> <p><u>230 VAC</u>: 1750 Watts of Heat</p> <p>Fluid Heating Range: 25°C to 42°C</p> <p>Time to Heat: 25°C to 42°C in 15 minutes or less</p>	<p style="text-align: center;"><u>SERVICEABILITY</u></p> <p>Special Tools Required - No</p> <p style="text-align: center;"><u>WARRANTY PERIOD</u></p> <p>1 year parts if not returned to GENTHERM.</p> <p>1 year parts and labor if returned to GENTHERM</p>
<p style="text-align: center;"><u>SERVICE LIFE</u></p> <p>The expected service life / lifetime of the Hemotherm Model 400CE is twelve (12) years from the date of manufacture provided the product is not subject to misuse, negligence, accident or abuse and under the conditions that the device is properly used as intended, and serviced and maintained according to the Operation / Technical Manual provided with the device.</p>	

1.12 ESSENTIAL PERFORMANCE TABLE

<p>Patient Protection</p> <ul style="list-style-type: none"> ▪ Water Temperature Control ▪ Water Temperature Setpoint Limits ▪ Water High Temperature Limit ▪ Water Low Temperature Limit ▪ Low Water Level in the Reservoir ▪ Temperature Sensor Malfunction ▪ Water Flow Rate
<p>System Pressure</p>

1.13 HEMOTHERM CLASSIFICATION AND CERTIFICATIONS

This unit is a Class II medical device according to the US FDA CDRH.

This unit has been certified to IEC 60601-1 Class I, Type BF Applied Part.



MODEL 400CE MEDICAL ELECTRICAL EQUIPMENT WITH RESPECT TO ELECTRIC SHOCK, FIRE AND MECHANICAL HAZARDS ONLY IN ACCORDANCE WITH UL60601-1, IEC60601-1, ASTM F2196-02, CAN/CSA-C22.2 No. 601.1 AND IEC60601-1-2

Manufactured under the quality system requirements of ISO 13485.
Degree of protection against harmful ingress of water is IPX0.

EMC COMPATIBILITY TABLES ACCORDING TO IEC 60601-1-2

Guidance and manufacturer's declaration – electromagnetic emissions		
The Hemotherm, Model 400CE is intended for use in the electromagnetic environment specified below. The customer or the user of this unit should assure that it is used in such an environment.		
Emissions tests	Compliance	Electromagnetic environment – guidance
RF emissions CISPR 11	Group 1	The Hemotherm, Model 400CE uses RF energy only for its internal function. Therefore, its RF emissions are very low and are not likely to cause any interference in nearby electronic equipment.
RF emissions CISPR 11	Class A	The Hemotherm, Model 400CE is suitable for use in all establishments other than domestic and those directly connected to the public low-voltage power supply network that supplies buildings used for domestic purposes.
Harmonic emissions IEC 61000-3-2	Class A	
Voltage fluctuations/ flicker emissions IEC 61000-3-3	Complies	

Guidance and manufacturer's declaration – electromagnetic immunity			
The Hemotherm, Model 400CE is intended for use in the electromagnetic environment specified below. The customer or the user of the Hemotherm, Model 400CE should assure that it is used in such an environment.			
Immunity test	IEC 60601 test level	Compliance level	Electromagnetic environment - guidance
Electrostatic discharge (ESD) IEC 61000-4-2	±6 kV contact ±8 kV air	±6 kV contact ±8 kV air	Floors should be wood, concrete or ceramic tile. If floors are covered with synthetic material, the relative humidity should be at least 30%.
Electrical fast transient/burst IEC 61000-4-4	±2 kV for power supply lines ±1 kV for input/output lines	±2 kV for power supply lines ±1 kV for input/output lines	Mains power quality should be that of a typical commercial or hospital environment.
Surge IEC 61000-4-5	±1 kV differential mode ±2 kV common mode	±1 kV differential mode ±2 kV common mode	Mains power quality should be that of a typical commercial or hospital environment.
Voltage dips, short interruptions and voltage variations on power supply input lines IEC 61000-4-11	<5% U_T (>95% dip in U_T) for 0,5 cycle 40% U_T (60% dip in U_T) for 5 cycles 70% U_T (30% dip in U_T) for 25 cycles <5% U_T (>95% dip in U_T) for 5 s	<5% U_T (>95% dip in U_T) for 0.5 cycle 40% U_T (60% dip in U_T) for 5 cycles 70% U_T (30% dip in U_T) for 25 cycles <5% U_T (>95% dip in U_T) for 5 s	Mains power quality should be that of a typical commercial or hospital environment. If the user of the Hemotherm, Model 400CE requires continued operation during power mains interruptions, it is recommended that the Hemotherm, Model 400CE be powered from an uninterruptible power supply or a battery.
Power frequency (50/60 Hz) magnetic field IEC 61000-4-8	3 A/m	3 A/m	Power frequency magnetic fields should be at levels characteristic of a typical location in a typical commercial or hospital environment.
Note: U_T is the a. c. mains voltage prior to application of the test level.			

Guidance and manufacturer's declaration – electromagnetic immunity			
The Hemotherm, Model 400CE is intended for use in the electromagnetic environment specified below. The customer or the user of the Hemotherm, Model 400CE should assure that it is used in such an environment.			
Immunity test	IEC 60601 test level	Compliance level	Electromagnetic environment - guidance
Conducted RF IEC 61000-4-6	3 Vrms 150 kHz to 80 MHz	3 Vrms	<p>Portable and mobile RF communications equipment should be used no closer to any part of the Hemotherm Model 400CE, including cables, than the recommended separation distance calculated from the equation applicable to the frequency of the transmitter.</p> <p>Recommended separation distance</p> $d = 1,2\sqrt{P}$
Radiated RF IEC 61000-4-3	3 V/m 80 MHz to 2,5 GHz	3 V/m	$d = 1,2\sqrt{P} \quad 80 \text{ MHz to } 800 \text{ MHz}$ $d = 2,3\sqrt{P} \quad 800 \text{ MHz to } 2,5 \text{ GHz}$ <p>Where P is the maximum output power rating of the transmitter in watts (W) according to the transmitter manufacturer and d is the recommended separation distance in meters (m).</p> <p>Field strengths from fixed RF transmitters, as determined by an electromagnetic site survey, ^a should be less than the compliance level in each frequency range. ^b</p> <p>Interference may occur in the vicinity of equipment marked with the following symbol:</p> 
NOTE 1: At 80 MHz and 800 MHz, the higher frequency range applies.			
NOTE 2: These guidelines may not apply in all situations. Electromagnetic propagation is affected by absorption and reflection from structures, objects and people.			
^a Field strengths from fixed transmitters, such as base stations for radio (cellular/cordless) telephones and land mobile radios, amateur radio, AM and FM radio broadcast and TV broadcast cannot be predicated theoretically with accuracy. To assess the electromagnetic environment due to fixed RF transmitters, an electromagnetic site survey should be considered. If the measure field strength in the location in which the Hemotherm, Model 400CE is used exceeds the applicable RF compliance level above, the Hemotherm, Model 400CE should be observed to verify normal operation. If abnormal performance is observed, additional measures may be necessary, such as re-orienting or relocating the Hemotherm, Model 400CE.			
^b Over the frequency range 150 kHz to 80 MHz, field strengths should be less than 3 V/m.			

Recommended separation distances between portable and mobile RF communications equipment and the Hemotherm, Model 400CE			
The Hemotherm, Model 400CE is intended for use in an electromagnetic environment in which radiated RF disturbances are controlled. The customer or the user of the Hemotherm, Model 400CE can help prevent electromagnetic interference by maintaining a minimum distance between portable and mobile RF communications equipment (transmitters) and the Hemotherm, Model 400CE as recommended below, according to the maximum output power of the communications equipment.			
Rated maximum output power of transmitter W	Separation distance according to frequency of transmitter m		
	150 kHz to 80 MHz $d = 1,2\sqrt{P}$	80 MHz to 800 MHz $d = 1,2\sqrt{P}$	800 MHz to 2,5 GHz $d = 2,3\sqrt{P}$
0,01	0,12	0,12	0,23
0,1	0,38	0,38	0,73
1	1,2	1,2	2,3
10	3,8	3,8	7,3
100	12	12	23
For transmitters rated at a maximum output power not listed above, the recommended separation distance d in meters (m) can be estimated using the equation applicable to the frequency of the transmitter, where P is the maximum output power rating of the transmitter in watts (W) according to the transmitter manufacturer.			
Note 1: At 80 MHz and 800 MHz, the separation distance for the higher frequency range applies.			
Note 2: These guidelines may not apply in all situations. Electromagnetic propagation is affected by absorption and reflection from structures, objects and people.			

Supplemental certification information available on request.

SECTION 2. OPERATING INSTRUCTIONS

2.1 INITIAL SET-UP

Steps 1-10 should be followed the first time the HEMOTHERM unit is set-up. For subsequent operation, refer to General Operation Instructions.

⚠ WARNING ⚠

Upon receipt of the HEMOTHERM, the unit should be disinfected per the WATER SYSTEM CLEANING & DISINFECTION PROCEDURE. Additionally, any unit removed from storage should be disinfected. **Failure to do so could result in patient and/or caregiver infection.**

1. Collect proper equipment and supplies.
 - A. HEMOTHERM unit.
 - B. Extracorporeal circuit with blood heat exchanger.
 - C. Hyper-Hypothermia blanket (optional).
 - D. 17 qts. (16 liters) of sterile water or water that has been passed through a filter of less than or equal to 0.22 microns. [The cool reservoir holds 8 qts. (7.6 liters), the heat reservoir holds 6 qts. (5.7 liters), the blanket (adult) holds 2 qts. (1.9 liters) and approximately 1.5 qts. (1.4 liters) will be required to fill the connecting lines and the heat exchanger]. No alcohol should be used.
2. Make sure power switch is in the OFF/"O" position.
3. Lift the reservoir lid and remove individual reservoir covers. Fill the cool reservoir with 8 qts. (7.6 liters) of sterile water or water that has been passed through a filter of less than or equal to 0.22 microns and the heat reservoir with 6 qts. (5.7 liters) of sterile water or water that has been passed through a filter of less than or equal to 0.22 microns. **The level should be approximately 1" from the top of each reservoir or just covering the bottom of the strainer.**
4. Insert plug into properly grounded, securely mounted receptacle. Grounding reliability can only be achieved when connected to an equivalent hospital grade receptacle. Do not bypass the third or grounding leg. An electrical hazard may result if it is bypassed, removed or otherwise rendered useless.
5. Place HEMOTHERM unit next to or near heat exchanger, or another convenient location.
6. Lay the Hyper-Hypothermia blanket on the O. R. table with hose attachments close to where the HEMOTHERM unit will be placed during operation. Cover the blanket with a sheet or water blanket.
7. Attach the heat exchanger and the blanket connecting lines (if desired) to the HEMOTHERM unit.

8. Read operating instructions on the control panel before starting the unit. Familiarize yourself with the name and location of all features and controls shown.
9. Fill the heat exchanger and blanket by pressing the power switch to the ON/"I" position. The HEMOTHERM will go through a self-calibration procedure with both displays blank and then through a fill mode. The displays will show EI on the Heat side and LL on the Cool side spelling out FILL. Then activate the heat/cool mode switch and then the pump switch. Add more sterile water or water that has been passed through a filter of less than or equal to 0.22 microns to the reservoir of the mode selected when filling.
10. Reference Section 1.8 GENERAL OPERATIONS for instructions on heating or cooling.

2.2 CONNECTION PROCEDURE

1. Take the set of 1/2" quick-connect fittings and attach two, 1/2" I.D. plastic tubes long enough to reach from the HEMOTHERM unit to the blood heat exchanger. The shorter the length of tubing will usually result in a better flow rate. **The female fitting should be attached to the tube leading to the blood heat exchanger water inlet and the male fitting should be attached to the blood heat exchanger water outlet.**
2. After attaching the tubes to the heat exchanger, attach the 1/2" quick-connect fittings to the matched fittings on the lower right side of the HEMOTHERM unit (see Figure 1.1).
3. Attach the 1/8" quick-connect fittings leading from the Hyper-Hypothermia blanket to the matching set of 1/8" quick-connect fittings on the lower right hand side of the HEMOTHERM unit.
4. The air in the lines will be bled out after the pump switch is activated. Check the water level of the reservoirs after filling connecting water lines.

2.3 DISPOSAL OF WASTE PRODUCTS

Dispose of pads in a means consistent with hospital policy protocol for patient contact items

The unit refrigerant must be handled and disposed of according to the requirements and laws of the local authority having jurisdiction.

2.4 SAFETY CONTROLS

1. Low Limit Equipment Safety will automatically shut off the compressor if the cold water reservoir temperature is $2^{\circ}\text{C} \pm 0.5^{\circ}\text{C}$. The low temperature limit LED will come on and the alarm will sound. This will also shut off the pump which will stop the circulation of water. The cooling system will come back on after approximately a 1°C temperature rise above the set point and the alarm will clear.

Note: This is a redundant system in that there are two independent Low Limit Equipment Safeties preset at 2°C .

2. Over temperature Limit Alarm will automatically monitor the actual heat side reservoir temperature and compare it to the heat side set point. If the actual display temperature increases above the set point by 1°C for longer than two (2) minutes the high temperature limit LED on the front panel will flash and the alarm will sound a short beep. Once the temperatures are within 1°C the alarm will clear.
3. Primary High Limit Equipment Safety will automatically shut off the heaters should the warm water reservoir temperature exceed the maximum 42°C and reach $44^{\circ}\text{C} \pm 0.5^{\circ}\text{C}$. The circulating pump will no longer operate. If this happens, a high temperature limit LED on the front panel will illuminate and the alarm will sound. The heating system will come back on after approximately a 1°C drop below the set point and the alarm will clear.
4. Secondary High Limit Equipment Safety is a redundant system that is safety preset at 46°C . If the device exceeds the maximum set-point of 42°C and the primary high temperature safety should happen to fail at 44°C , a high temp light on the control panel will illuminate and alarm at $46^{\circ}\text{C} \pm 0.5^{\circ}\text{C}$ and the heaters will turn off automatically. The circulating pump will no longer operate. If this happens, a high temperature limit LED on the front panel will illuminate and the alarm will sound. **The system should be inspected by the hospital's maintenance or engineering department. This is a Remove from Service (RFS) alarm.**
5. Circuit Breaker - The HEMOTHERM unit (right side) is equipped with an over-current protection circuit breaker built into the power switch to protect the unit wiring system against possible overload.

SECTION 3. MAINTENANCE AND REPAIR

3.1 GENERAL

The HEMOTHERM Cooler/Heater unit is designed and built to be field serviceable. The repair, calibration and servicing of this unit requires no special tools, except for refrigeration repairs. However, no attempt should be made to perform any of these procedures unless the proper skills and knowledge are possessed. Repair or service of the HEMOTHERM by qualified medical personnel will not void the warranty of the unit.

WARNING

Before performing any disassembly procedure, be sure the power switch is in the OFF/"O" position and the power cord is unplugged from the receptacle. **Electrical Hazards may result.**

All internal operating components are readily exposed by removing the rear panel. This is accomplished by removing the five retaining screws around the perimeter of the panel. Pull rear panel away from the unit.

Access to the condenser grille is attained by removing the air intake vent at the front of the HEMOTHERM unit. To do this, remove the four screws securing the vent to the unit.

3.2 EXTERNAL CLEANING INSTRUCTIONS

The HEMOTHERM unit and Remote Control are constructed of powder coated steel with a plastic membrane control panel. For cleaning and disinfecting, use tuberculocidal wipes. Avoid 100% alcohol and other strong, undiluted disinfectants. These may cause staining of the device's outer skin. **Wipe down the entire exterior of the device paying extra attention to crevices on the device.**

NOTE: Surfaces are to remain wet for the duration specified by the wipe's instructions. Use wipes that have bleach (sodium hypochlorite) as an active ingredient to avoid discoloration of the unit.

3.3 FUSE REPLACEMENT

All fuses are located on the power board. These fuses are not recommended to be replaced.

The main power switch also includes an integrated circuit breaker.

3.4 LOW LIMIT EQUIPMENT SAFETIES CHECK

⚠ WARNING ⚠

The repair, calibration, and servicing of the HEMOTHERM should be performed by qualified Medical Equipment Service Technicians, Certified Biomedical Electronics Technicians, or Certified Clinical Engineers familiar with good repair practices for servicing medical devices, and in accordance with instructions contained in this manual. **Improper repair can result in damage to the HEMOTHERM system and patient injury.**

Always **unplug the unit** before accessing internal components during service. Failure to unplug the unit could result in **electric shock**.

Low Limit Safety Check

1. Turn the HEMOTHERM power switch to the OFF/"O" position to turn unit off and plug the unit into the appropriate power supply.
2. Remove membrane control panel from the front of the unit, and locate the test jumper in the storage position JP2 on the back of the control board. Support the control panel so as to not strain the wires. Refer to Figure 4-8, Control PCB Diagram for JP2 location.
3. Place the jumper on the test port in the location marked **LC**.
4. Press the power switch to the ON/"I" position to turn the unit on. JP will display on the heat side and the cool side display will monitor the temperature as the water is cooled.
5. The unit should cool the water to the Primary Low Limit Safety of 2.0°C +0.5 / - 1.0°C and shut off. The LOW TEMP. LIMIT light will be on and the speaker will alarm.
6. Turn the unit off.
7. Allow the water temperature to rise above 4.0°C, or drain reservoir and refill to raise the temperature.
8. Place the jumper on the test port in the location marked **LS**.
9. Turn the unit on. JP will display on the heat side and the cool side display will monitor the temperature as the water is cooled.
10. The unit should cool the water to the Secondary Low Limit Safety of 2.0°C +0.5 / -1.0°C and shut off. The LOW TEMP. LIMIT light will be on and the speaker will alarm.
11. Turn the unit off and place the jumper back in its storage location JP2.
12. Allow the water temperature to rise above 4.0°C, or drain reservoir and refill to raise the temperature. Reinstall membrane control panel to the front of the unit.

3.5 HIGH LIMIT EQUIPMENT SAFETIES CHECK

⚠ WARNING ⚠

The repair, calibration, and servicing of the HEMOTHERM should be performed by qualified Medical Equipment Service Technicians, Certified Biomedical Electronics Technicians, or Certified Clinical Engineers familiar with good repair practices for servicing medical devices, and in accordance with instructions contained in this manual. **Improper repair can result in damage to the HEMOTHERM system and patient injury.**

Always **unplug the unit** before accessing internal components during service. Failure to unplug the unit could result in **electric shock**.

A. Control High Limit Check

1. Turn the HEMOTHERM power switch to the OFF/"O" position to turn unit off and plug the unit into the appropriate power supply.
2. Remove membrane control panel from the front of the unit, and locate the test jumper in the storage position JP2 on the back of the control board. Support the control panel so as to not strain the wires. Refer to Figure 4-8, Control PCB Diagram for JP2 location.
3. Place the jumper on the test port in the location marked **HC**.
4. Press and hold the TEST INDICATORS and SILENCE ALARM buttons while pressing the power switch to the ON/"I" position to turn the unit on. JP will display on the cool side display and the heat side display will monitor the temperature as the water is heated.
5. The unit should heat the water to the Primary High Limit Safety of 44.0°C +1.0 / -0.5°C and shut off. The HIGH TEMP. LIMIT light will be on and the speaker will alarm.
6. Turn the unit off.
7. Allow the water temperature to fall below 42.0°C, or drain reservoir and refill to lower the temperature.
8. Turn the unit on. JP will display on the cool side display and the heat side display will monitor the temperature as the water is heated.
9. The unit should heat the water to the Secondary High Limit Safety of 46.0°C +1.0 / -0.5°C and shut off. The HIGH TEMP. LIMIT light will be on and the speaker will alarm. **This is the Remove from Service (RFS) alarm.**
10. Turn the unit off and place the jumper back in its storage location JP2.
11. Allow the water temperature to fall below 42.0°C, or drain reservoir and refill to lower the temperature.
12. Press and hold the COOL INCREMENT BUTTON, COOL TEMP SET BUTTON, and SILENCE ALARM buttons while turning the unit on. This will reset the RFS alarm.

13. Turn the unit off.

Safety High Limit Check

1. Turn the HEMOTHERM power switch to the OFF/"O" position to turn unit off and plug the unit into the appropriate power supply.
2. Remove membrane control panel from the front of the unit, and locate the test jumper in the storage position JP2 on the back of the control board. Support the control panel so as to not strain the wires. Refer to Figure 4-8, Control PCB Diagram for JP2 location.
3. Place the jumper on the test port in the location marked **HS**.
4. Press and hold the TEST INDICATORS and SILENCE ALARM buttons while pressing the power switch to the ON/"I" position to turn the unit on. JP will display on the cool side display and the heat side display will monitor the temperature as the water is heated.
5. The unit should heat the water to the Primary High Limit Safety of 44.0°C +1.0 / -0.5°C and shut off. The HIGH TEMP. LIMIT light will be on and the speaker will alarm.
6. Turn the unit off.
7. Allow the water temperature to fall below 42.0°C, or drain reservoir and refill to lower the temperature.
8. Turn the unit on. JP will display on the cool side display and the heat side display will monitor the temperature as the water is heated.
9. The unit should heat the water to the Secondary High Limit Safety of 46.0°C +1.0 / -0.5°C and shut off. The HIGH TEMP. LIMIT light will be on and the speaker will alarm. **This is the Remove from Service (RFS) alarm.**
10. Turn the unit off and place the jumper back in its storage location JP2.
11. Allow the water temperature to fall below 42.0°C, or drain reservoir and refill to lower the temperature.
12. Press and hold the COOL INCREMENT BUTTON, COOL TEMP SET BUTTON, and SILENCE ALARM buttons while turning the unit on. This will reset the RFS alarm.
13. Turn the unit off.
14. Reinstall membrane control panel to the front of the unit.

3.6 TEMPERATURE ACCURACY CHECK

For temperature accuracy and verification it is recommended to use a calibrated thermometer (with $\pm 0.1^{\circ}\text{C}$ accuracy or better) located as close as possible to the reservoir water temperature sensor. For best accuracy be certain that the thermometer is not near the heater or evaporator coil when you are taking measurements.

3.7 MAINTENANCE OF THE WATER RESERVOIRS

Monthly, at a minimum, the reservoirs should be drained, wiped down with tuberculocidal wipes and refilled with sterile water or water that has been passed through a filter of less than or equal to 0.22 microns.

CAUTION

For safe handling and use of chemicals follow manufacturer guidelines.
--

The reservoirs should be maintained at least once a month, more often if possible.

To empty the reservoirs, first make sure the power switch is in the OFF/"O" position. Then, attach the 1/4" female coupling of the drain tube over either of the 1/4" male fittings marked "DRAIN" on the side of the unit. Allow gravity to drain the water from the one reservoir and then repeat for the other one. If draining unit into a container, be sure that the container has a capacity of at least five gallons (13.3 liters).

Remove the reservoir covers by lifting the cover at the strainer handle. Prior to refilling, clean the underside of both reservoir lids using a tuberculocidal wipe. Clean any residue from the bottom and sides of the empty reservoir and wipe down with tuberculocidal wipes. Pay extra attention to the areas not in the water pathways, such as the lid of each reservoir, and the top section of the water reservoir.

NOTE: Surfaces are to remain wet for the duration specified by the wipe's instructions. Use wipes that have bleach (sodium hypochlorite) as an active ingredient to avoid discoloration of the unit.

Place the reservoir covers back on the proper reservoir. Refill the reservoir with sterile water or water that has been passed through a filter of less than or equal to 0.22 microns. The capacity of the reservoirs is - 6 qts (5.7 liters) for the heat reservoir and 8 qts. (7.6 liters) for the cool reservoir. Under all circumstances, the reservoirs should be filled before starting the HEMOTHERM unit. It is not necessary to drain the reservoirs after each use.

3.8 WATER SYSTEM CLEANING & DISINFECTION PROCEDURE

Quarterly, at a minimum, the **FLUID CIRCUIT CLEANING & DISINFECTION/DRY STORAGE PROCEDURE**, listed below, should be conducted.

Use new accessories, tubing, and connectors to prevent possible recontamination when using a different heater-cooler device.

CAUTION

For safe handling and use of chemicals follow manufacturer guidelines.

Use only sterile water or water that has been passed through a filter of less than or equal to 0.22 microns. Do not use deionized water. Do not use alcohol. Alcohol may cause blanket and/or unit deterioration. Do not use tap water to rinse, fill, refill or top-off water tanks.

FLUID CIRCUIT CLEANING & DISINFECTION/DRY STORAGE PROCEDURE

The following procedure disinfects the fluid circuit in these products. The required tools/supplies are:

- Drain hose (P/N 93807) and Bypass hose, if applicable, (P/N 93817)
- Agency registered¹ tuberculocidal wipes
- Cleaning Agent²: Prolystica® 2X Concentrate Enzymatic Presoak and Cleaner
- Disinfectant²: 6% bleach or 8.25% bleach
- Sterile water or water that has been passed through a filter of less than or equal to 0.22 microns
- pH strips
- Appropriate AC electrical power.

Procedure:

1. Turn unit off ("O" position).
2. Remove any blood heat exchangers, Hyper-Hypothermia blankets, and hoses that are connected to the unit.
3. Drain the water from each reservoir as described in MAINTENANCE OF THE WATER RESERVOIRS.
4. Using a tuberculocidal wipe, wipe down the reservoirs and the underside of both reservoir lids. Pay extra attention to the areas not in the water pathways, such as the lid of each reservoir, and the top section of the water reservoir.

NOTE: Surfaces are to remain wet for the duration specified by the wipe's instructions. Use wipes that have bleach (sodium hypochlorite) as an active ingredient to avoid discoloration of the unit.

¹ ARTG registered, EPA Registered, Health Canada licensed

² Australian Register of Therapeutic Goods (ARTG) #151419

² Health Canada Drug Identification Number (DIN) 6% bleach (DIN 02459116) or 8.25% bleach (DINs 02459108 or 02438100)

- Add to each reservoir the appropriate amount of Prolystica® 2X Concentrate Enzymatic Presoak and Cleaner and sterile water or water that has been passed through a filter of less than or equal to 0.22 microns per the chart below:

RESERVOIR	Prolystica 2X Concentrate	STERILE/FILTERED WATER	TEMPERATURE
COOL	30.4 Milliliters	7.6 Liters	20°C
HEAT	22.8 Milliliters	5.7 Liters	42°C

- Turn the unit on (“I” position). Confirm that the Heat Side is set to 42°C. Set the Cool Side to 20°C. Allow both sides to reach temperature before continuing.
- Press PUMP and circulate for the time specified in the chart below for both Cool and Heat modes. The unit utilizes an internal shunt to complete the circulation path.

	Blanket Connection/Return	Disinfecting Cycle Time per Mode
Combination 1	N/A – Hemotherm Only	5 min

- Press PUMP to stop the unit’s circulation.
- Per the below table, add the appropriate amount of bleach to the water & Prolystica® 2X Concentrate Enzymatic Presoak and Cleaner in each reservoir.

NOTE: The type of bleach is based on the sodium hypochlorite content. This can be found on the bottle where the active ingredients are listed.

RESERVOIR	TEMPERATURE	BLEACH	
		6% Sodium Hypochlorite	8.25% Sodium Hypochlorite
COOL	20°C	320 Milliliters	230 Milliliters
HEAT	42°C	235 Milliliters	170 Milliliters

- Press PUMP and circulate for the time specified in the chart below each in both cool and heat modes. The unit utilizes an internal shunt to complete the circulation path.

	Blanket Connection/Return	Disinfecting Cycle Time per Mode
Combination 1	N/A – Hemotherm Only	5 min

- Drain each reservoir as instructed in Section 3.7.
- Rinse the unit
 - Refill the unit with sterile water or water that has been passed through a filter of less than or equal to 0.22 microns until the water touches the strainer for both reservoirs.
 - Circulate the water per the chart below in both cool and heat modes.

	Blanket Connection/Return	Disinfecting Cycle Time per Mode
Combination 1	N/A – Hemotherm Only	5 min

- Drain each reservoir as instructed in Section 3.7.

- Repeat step 13 twice more for a total of three rinses.

14. After the third rinse, refill the unit with sterile water or water that has been passed through a filter of less than or equal to 0.22 microns until the water touches the strainer for both reservoirs. Circulate the water for 1 minute in each mode.
15. Check the water with pH strips or other appropriate test method for detecting bleach. If bleach is detected, repeat Steps 13-15.

NOTE: To avoid damage to the unit, the pH should be approximately 7. Use the guide provided with the pH strips or other appropriate test method to interpret the reading. Different strips should be used to test each reservoir.

16. If unit is being **returned to service** proceed to Step 19.
17. If unit is being **placed in dry storage** proceed to Step 20.
18. **RETURNING TO SERVICE:** Ensure that the water reservoirs are filled with sterile water or water that has been passed through a filter of less than or equal to 0.22 microns. Turn off the unit and proceed to Step 24.

NOTE: If a full unit is sitting for longer than 30 days, it should be cleaned & disinfected, drained and put in storage.

19. **FOR DRY STORAGE:** If unit is being placed in dry storage, do the following steps.
20. Drain the water from each reservoir as described in the Section 3.7.
21. When all fluid has been removed from the unit, disconnect the drain hose(s) and wipe unit clean.
22. Unit is now ready for storage. Refer to Section 1.11 for specifications for storage conditions.
23. Remove any accessories attached to the unit. Document unit maintenance per Gentherm and hospital protocol. (Maintenance records can be found in Sections 3.20 & 3.21).

When you are ready to return unit from storage, repeat the above disinfection procedure. Perform all the checks as described in this Manual.

3.9 MAINTENANCE OF THE WATER FILTER

WARNING

Always **unplug the unit** before accessing internal components during service. Failure to unplug the unit could result in **electric shock**.

The HEMOTHERM circulating system includes a water filter designed to clear the line of particulate matter as the water is pumped through the system. The water filter assembly is a plastic T-shaped fitting that intersects the hose from the pump to the outlet manifold. A stainless steel wire-mesh screen is located inside the clear plastic cap of the water filter assembly.

Once every three months, or more often if deemed necessary, the water filter should be disassembled and cleaned. To do so, the rear enclosure panel must be removed. The

cap of the water filter assembly should then be unscrewed. The wire mesh and the plastic cap should then be disinfected. The parts are then to be reassembled.

1. Press the power switch to the OFF/"O" position.
2. Disconnect the unit from its power source.
3. Drain both of the unit's water reservoirs as described in the Section 3.7.
4. Remove the five screws holding on the rear enclosure panel. Guide the panel outward towards the floor.
5. Locate the water filter assembly (shown below).



6. Firmly grasp the notched rim of the cap of the assembly and remove. The cap and hose will contain water if the unit was used prior to cleaning. The wire mesh may be lodged in the top of the fitting or it may be resting in the plastic cap.

NOTE: Water in hose lines and cap present a slip and fall hazard

7. Remove the wire mesh.
8. Clean the wire mesh and the plastic cap with a tuberculocidal wipe. Be careful not to lose the black O-ring in the rim of the plastic cap.

NOTE: Surfaces are to remain wet for the duration specified by the wipe's instructions. Use wipes that have bleach (sodium hypochlorite) as an active ingredient to avoid discoloration of the unit.

9. Replace the wire mesh in the plastic cap and position the wire mesh, O-ring and plastic cap under the fitting.

NOTE: If the black O-ring is not present in the plastic cap when the cap is returned to the unit, water can leak from the device.

10. Screw the cap clockwise on to the fitting until it is secure.

NOTE: If the plastic cap is not screwed back on at the correct angle, or is not screwed on tightly, water can leak from the device.

11. Replace the rear enclosure. Replace the five screws.

12. Document unit maintenance. (Maintenance records can be found in Sections 3.20 & 3.21).

3.10 MAINTENANCE OF THE CONDENSER GRILLE

Cool air is taken in through the grille at the front of the HEMOTHERM unit. Warm air is expelled through the bottom of the unit. Both the air intake and outlet must be kept clear when the machine is in operation.

If the condenser grille becomes covered with dust and lint, the cooling capacity of the unit will be reduced. **AT LEAST EVERY MONTH THE CONDENSER SHOULD BE CLEANED.** To do this, first loosen the four screws securing the condenser grille over the condenser intake. Then, remove accumulated dust or lint with a brush or vacuum. Wipe down both sides of the condenser grille with a tuberculocidal wipe. Finally, replace condenser grille and tighten all four screws.

NOTE: Surfaces are to remain wet for the duration specified by the wipe's instructions. Use wipes that have bleach (sodium hypochlorite) as an active ingredient to avoid discoloration of the unit.

3.11 MAINTENANCE OF THE HYPER-HYPOTHERMIA BLANKETS

This section describes the general maintenance for the disposable blankets. General maintenance tasks include cleaning, draining, and storing the blankets. For further maintenance information on Gentherm blankets refer to the blanket's corresponding Instructions for Use.

Disposable, Single-Patient Use Blankets

Dispose of single-patient use blankets per hospital/institution policy/protocol.

3.12 REPLACING THE HEATER

1. Press the power switch to the OFF/"O" position.
 2. Disconnect the unit from its power source.
 3. Drain water from heat reservoir.
 4. Unseat the control panel by removing the four screws securing it to the unit.
 5. Carefully open the electrical area by pulling the control panel forward.
 6. Locate the J3 connector on the power circuit board.
 7. Remove heater wires as indicated on the wiring diagram
 8. Remove rear enclosure panel by removing the screws securing the panel to the unit.
 9. Locate the heater in the middle portion of the heat reservoir as seen when viewing the unit from the back.
 10. Remove heater wires from the wiring area towards the back of the unit.
 11. Remove heater from reservoir.
 12. Align the holes of the replacement heater rod/mounting assembly with the studs of the heater attachment ring.
 13. Ensure the orientation arrow on the Heater Wire Assembly is in the vertical direction, pointing towards the top of the heat reservoir.
 14. Continue to reinstall heater, wires and connector in reverse order of disassembly. Reference the wiring diagram for proper termination placement.
 15. Refill reservoir with sterile water or water that has been passed through a filter of less than or equal to 0.22 microns and check for leaks.
 16. Replace the rear enclosure panel. Tighten the screws.
 17. Confirm proper operation of the unit prior to returning to service.
-

3.13 REPLACING PUMP HOUSING OR PUMP

1. Press the power switch to the OFF/"O" position.
2. Disconnect the unit from its power source.

3. Locate the pump housing towards the lower back side of the inside of the unit.
4. Disconnect rubber hoses from inlet and outlet housings.

NOTE: If just the pump is to be replaced, skip steps 5 - 8.
5. Remove the three bolts holding the pump to the base.
6. Remove the seven screws securing pump housing to pump motor.
7. Remove the fitting from the housing.
8. Insert the fitting from the defective pump housing in step 7 above into the identical orifice of the new pump housing. Seal the fitting with Teflon tape or equivalent.
9. Secure new pump housing by replacing the seven screws removed in step 6 above. Do not tighten screws sequentially in either clockwise or counterclockwise direction. Tighten one screw, then a screw opposite it, etc.
10. Remount pump with the three bolts attached to the base.
11. Reattach hoses to inlet and outlet.
12. Plug unit into properly grounded receptacle.
13. Confirm proper operation of the unit prior to returning to service.

3.14 REPLACING THE SENSOR

1. Press the power switch to the OFF/"O" position.
2. Disconnect the unit from its power source.
3. Drain proper reservoir; depending on which sensor is being replaced. There is one dual thermistor temperature sensing probe located in each water reservoir.
4. Remove rear enclosure panel by removing the screws securing the panel to the unit.
5. Disconnect wire plug located approximately 6" from the sensor fitting. Remove the sensor from the proper reservoir.
6. Place the new sensor into the reservoir and tighten.
7. Connect wire plug.

8. Replace rear enclosure panel and tighten all screws.
9. Refill water reservoir and check for leaks.
10. Confirm proper operation of the unit prior to returning to service.

3.15 REPLACING THE POWER BOARD

⚠Note ⚠
NO food or drink shall be in the workspace
⚠CAUTION ⚠
Be careful to not put any strain on any of the electrical cables connected to the circuit boards.
Working with electronic boards, plugs, and cables requires delicate handling. Proper Electrostatic Discharge procedure should be followed during replacement of any electronic board.
⚠WARNING ⚠
Before performing any disassembly procedure, be sure the power switch is in the OFF/"O" position and the power cord is unplugged from the receptacle. Electrical Hazards may result.

1. Unscrew four (4) mounting screws from the Control Panel using a Philips Head Screwdriver.

NOTE: *Save the screws for Step 21 of this procedure.*



Figure 5

2. Carefully tip the control panel outward to access the electrical enclosure as shown in *Figure 6*.

NOTE: Do NOT put strain on any of the electrical cables.



Figure 6

3. Using a Philips Head Screwdriver, unscrew two (2) screws from the remote cable and disconnect the cable from the control board at J1.

NOTE: Save screws for *Step 18* of this procedure.



Figure 7

4. Disconnect the cable from the control board at J2. For removal, pinch the sides of J2.

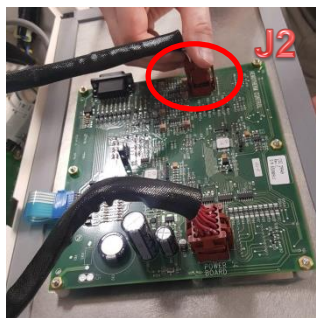

Figure 8

5. Disconnect the J5 cable from the power board. For removal, pinch the sides of J5.

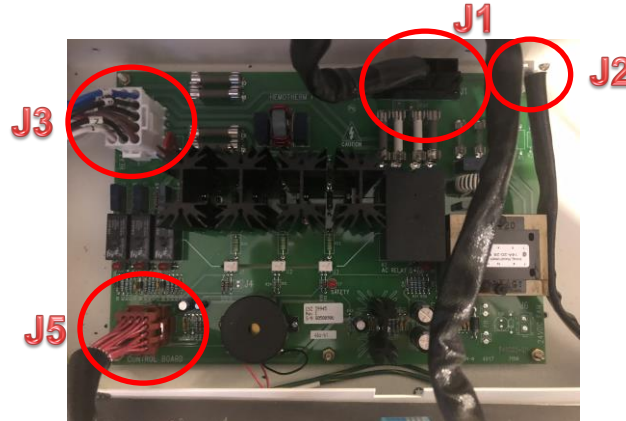

Figure 10 – Top View of Power Board in Place

6. Set aside the control panel, making sure not to damage any of the components.
NOTE: Place the control panel in an ESD safe environment
7. Disconnect three (3) cables from the power board at J1, J2, and J3 as shown in Figure 10 above. For removal, pinch the sides of J2 and J3.
8. Using a 5/16" nut driver, remove the six (6) nuts from the studs that secure the power board.
NOTE: Save the nuts for Step 12 of this procedure.
9. Carefully remove the power board from the original position.
NOTE: Place the power board in an ESD safe environment.



Figure 11

10. Properly dispose of the original power board per local regulations for electronics.
11. Obtain a replacement power board.

12. Place the new power board into the cabinet, aligning the mounting holes on the board with the bolts at the bottom of the cabinet.

NOTE: Ensure the power board is aligned as shown in *Figure 10* with J1 and J2 at the top of the board.

13. Secure the power board with six (6) nuts from Step 8 using a 5/16" nut driver.



Figure 12

14. Plug in each of the cables into the new Power Board at J1, J2, and J3 as shown in *Figure 13*.

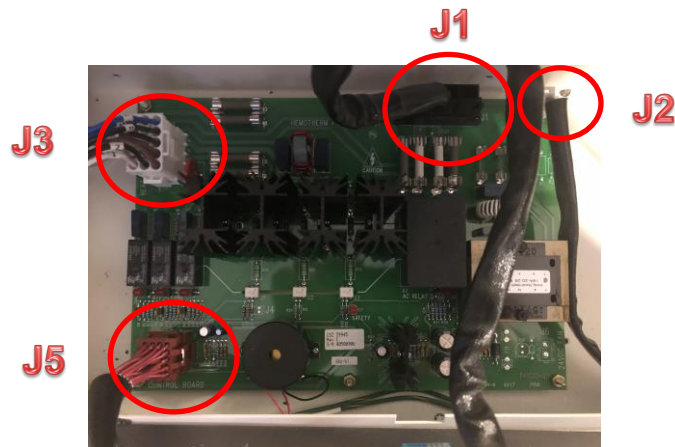

Figure 13

15. Obtain the control panel set aside earlier.

16. Plug in the cables into the new Power Board at J5 as shown in *Figure 13*

17. Plug in the J2 cable into the control board as shown in Figure 14. Verify that the connections are fully seated.

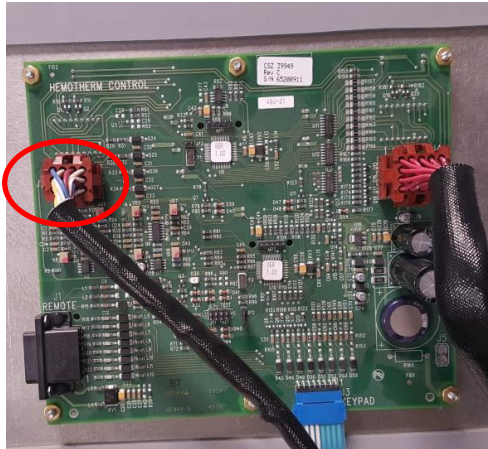

Figure 14

18. Plug in the remote cable into J1 and secure the cable with two screws from Step 3 using a Philips Head Screwdriver.

NOTE: *Over-tightening will damage the cable.*



Figure 15

19. Verify that there is no debris or tools in the electronics enclosure. Visually inspect the electronics area, cabling, and circuit boards.
20. Place the control panel on the cabinet ensuring there are no wires being pinched, and that the ribbon cable sits within the slot on the cabinet.
21. Secure the control panel onto a cabinet with four (4) mounting screws from Step 1 using a Philips Head Screwdriver.
- NOTE:** *Hand-tighten each screw until a portion of the black gasket becomes visible along the corner of the control panel.*



Figure 16

22. If needed, fill the unit with water per the *Hemotherm Operation & Technical Manual*.
23. Plug the unit into a properly grounded receptacle and turn the unit on.
24. Verify the unit completes FILL Mode.
NOTE: “FI” and “LL” will appear in the heat and cool side LCD’s, respectively.
25. Verify all of the buttons on the control panel are functional by pressing each button.
NOTE: the function of each button is described in **DESCRIPTION, EXTERNAL FEATURES AND PRODUCT PARTS** section of the *Hemotherm Operation & Technical Manual*.
NOTE: if using the Remote Control, verify all of the buttons on the remote control are functional by pressing each button.
26. Verify earth leakage currents are still acceptable under conditions described in the *Hemotherm Operation & Technical Manual*.
27. Perform Low Limit and High Limit Equipment Safeties Check per the *Hemotherm Operation & Technical Manual*

3.16 REPLACING THE CONTROL PANEL

⚠ NOTE ⚠

NO food or drink shall be in the workspace

⚠ CAUTION ⚠

Working with electronic boards, plugs, and cables requires delicate handling. **ESD grounding strap shall be worn during replacement of any electronic board.**

⚠ WARNING ⚠

Before performing any disassembly procedure, be sure the power switch is in the OFF/"O" position and the power cord is unplugged from the receptacle. **Electrical Hazards may result.**

1. Unscrew four (4) mounting screws from the Control Panel using a Philips Head Screwdriver.

NOTE: Save the screws for Step 19 of this procedure.



Figure 17

2. Carefully tip the control panel outward to access the electrical enclosure as shown in Figure 18.

NOTE: Do NOT put strain on any of the electrical cables.



Figure 18

3. Using a Philips Head Screwdriver, unscrew two (2) screws from the remote cable and disconnect the cable from the control board at J1.

NOTE: Save screws for Step 16 of this procedure.

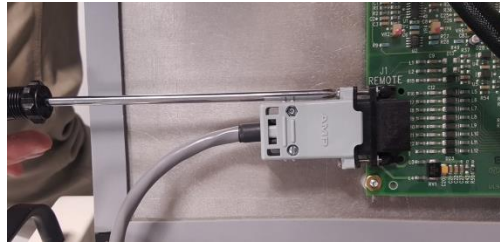

Figure 19

4. Disconnect three (3) cables from the control board at J2, J3, and J4. For removal, pinch the sides of J2 and J4.

NOTE: Do not damage the capacitor near J4 as shown in Figure 21.

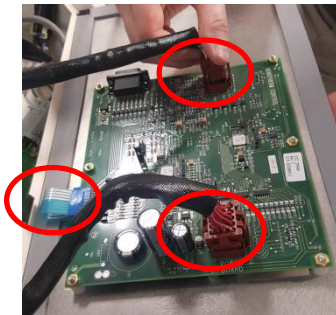

Figure 20

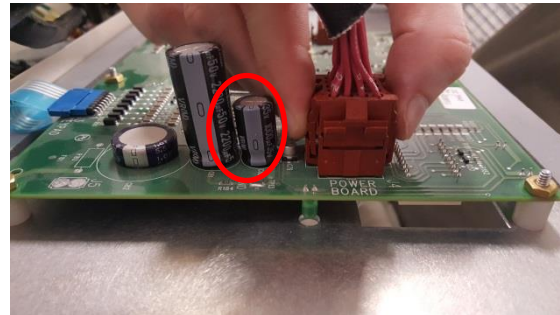

Figure 21

5. Using a 5/16" nut driver, remove six (6) nuts and six (6) lock washers from the studs that secure the control board.

NOTE: Save the lock washers and nuts for Steps 12 and 13 of this procedure, respectively.



Figure 22

- Carefully remove the control board from the original control panel.

NOTE: Place the control board in an ESD safe environment.

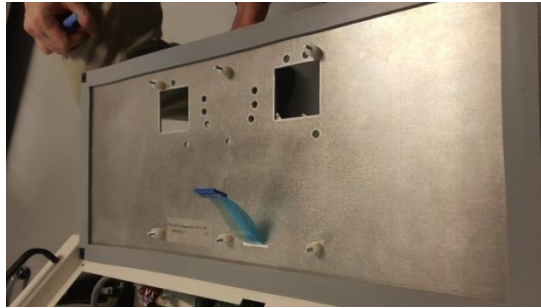

Figure 23

- Carefully, remove six (6) plastic standoffs from the original control panel.

NOTE: Save the plastic standoffs for Step 10 of this procedure.

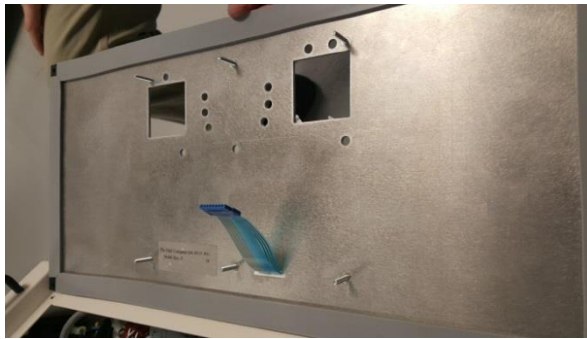

Figure 24

- Properly dispose of the original control panel per local regulations for electronics.

- Obtain a replacement control panel.

- Place six (6) plastic standoffs from Step 7 on the replacement control panel, ensuring that the control panel is oriented with the ribbon cable at the bottom.



Figure 25

- Place the control board from Step 6 on the new control panel as shown in *Figure 26*, ensuring that the control board is oriented with J3 aligning with the control panel ribbon.

NOTE: Be careful not to kink or crease the control panel ribbon during installation.



Figure 26

- Place a lock washer through each stud that secures the control board as shown in *Figure 27*.



Figure 27

- Secure the control board with six (6) nuts from Step 5 using a 5/16" nut driver.



Figure 28

14. Plug in the ribbon cable from a new Control Panel at J3 as shown in *Figure 29*.

NOTE: Do NOT twist the ribbon cable and ensure all pins are connected.

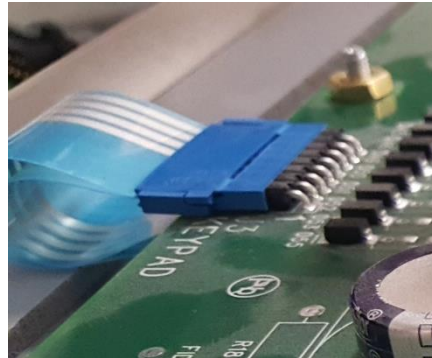

Figure 29

15. Plug in the other two (2) cables at J2 and J4 as shown in *Figure 30*. Verify that the connections are fully seated.

NOTE: The connectors are keyed such that there is only one way to insert. Do not damage the capacitor near J4.

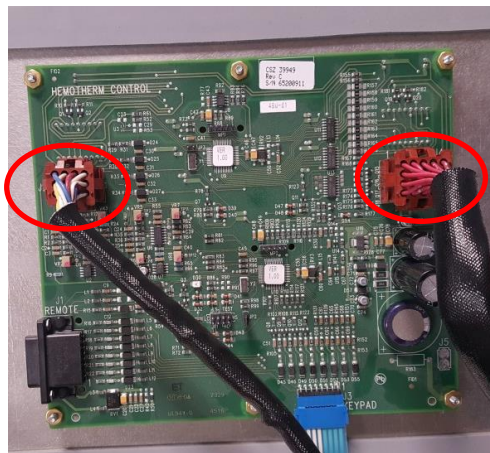

Figure 30

16. Plug in the remote cable into J1 and secure the cable with two screws from Step 3 using a Philips Head Screwdriver.

NOTE: Over-tightening will damage the cable.



Figure 31

17. Verify that there is no debris or tools in the electronics enclosure. Visually inspect the electronics area, cabling, and circuit boards.
18. Place the control panel on the cabinet ensuring there are no wires being pinched, and that the ribbon cable sits within the slot on the cabinet.
19. Secure the control panel onto a cabinet with four (4) mounting screws from Step 1 using a Philips Head Screwdriver.
NOTE: *Hand-tighten each screw until a portion of the black gasket becomes visible along the corner of the control panel.*



Figure 32

20. If needed, fill the unit with water per the *Hemotherm Operation & Technical Manual*.
21. Plug the unit into a properly grounded receptacle and turn the unit on.
22. Verify the unit completes FILL Mode.
NOTE: *“FI” and “LL” will appear in the heat and cool side LCD’s, respectively.*
23. Verify all of the buttons on the control panel are functional by pressing each button.
NOTE: *the function of each button is described in **DESCRIPTION, EXTERNAL FEATURES AND PRODUCT PARTS** section of the *Hemotherm Operation & Technical Manual*.*
NOTE: *if using the Remote Control, verify all of the buttons on the remote control are functional by pressing each button.*
24. Verify earth leakage currents are still acceptable under conditions described in the *Hemotherm Operation & Technical Manual*.
25. Perform Low Limit and High Limit Equipment Safeties Check per the *Hemotherm Operation & Technical Manual*.

3.17 REPLACING THE WATER MANIFOLD

1. Press the power switch to the OFF/"O" position.
2. Disconnect the unit from its power source.
3. Drain the water from each reservoir.
4. Remove rear enclosure panel by removing the five screws securing it to the unit.
5. Locate manifolds in the lower left side when viewing the unit from the back.
6. Disconnect rubber hoses at the ends of the manifold.
7. Unscrew both outlet/male fittings and both inlet/female fittings from outside of unit.
8. Remove the whole manifold. Replace with new manifold. Replace all fittings with the male fittings on the top and the female fittings on the bottom and seal using Teflon tape or equivalent.
9. Reconnect the rubber hoses to the new manifold.
10. Refill reservoirs with sterile water or water that has been passed through a filter of less than or equal to 0.22 microns.
11. Check manifold for leaks prior to return to service.

3.18 MEASURING LEAKAGE CURRENT

Using a calibrated electrical safety analyzer, measure electrical leakage current of the HEMOTHERM unit under the following conditions: Power ON and OFF, polarity normal and reverse, unit grounded and ungrounded. Under all test conditions the earth leakage current should be less than 300 micro amps (μA) for 115V units and less than 500 micro amps (μA) for 230V units. If a HEMOTHERM unit has leakage current that exceeds the allowable micro amps or has a significant increase in leakage current, the cause should be investigated.

Excessive leakage current is most commonly caused by a defective heater, but other components can also fail in such a way as to increase leakage current. To find the source of excessive leakage current, suspect components should be sequentially disconnected (both conductors or inputs) until the source of the high leakage is isolated.

3.19 REMOVE FROM SERVICE ALARM (RFS)

The Remove from Service (RFS) alarms are a visual and audio indication of a possible error condition in the temperature control system. The RFS alarms will require the unit to

be inspected by the hospital's biomedical or maintenance department and, if required, repaired immediately. The following are an indication that an RFS alarm condition has occurred:

- An “EE” on the HEAT side temperature display and an error number (2, 3, 5, or 6) on the COOL side temperature display.
- Temperature in the HEAT side reservoir exceeding the secondary high limit safety is also an RFS alarm and will be indicated by the HIGH TEMP. LIMIT red LED indicator and the beeper.
- A power fail condition is NOT an RFS alarm and will be indicated by the POWER FAIL LIGHTS red LED indicators and the beeper once a power failure is detected for 5 seconds or greater. If the SILENCE ALARM button is held, the power fail alarm and LED will cease. Upon repowering the unit, the alarm continues to sound until the SILENCE ALARM button is pressed.

All RFS alarms are announced by an audible beeper that cannot be muted by pressing the SILENCE ALARM button. The state of the RFS alarm is saved in the unit's internal memory and will not clear until the error is corrected and the RFS reset sequence is performed.

Once the error condition has been corrected, the following RFS reset sequence needs to be performed to clear the alarm from the equipment's internal memory:

Press and hold the COOL INCREMENT BUTTON (Up Arrow) and COOL TEMP SET BUTTON and SILENCE ALARM buttons to clear the RFS alarm.

This will reset the RFS alarm, silence the audible beeper, and turn off the LED indicator.

3.20 REQUIRED QUARTERLY PREVENTIVE MAINTENANCE CHECKLIST

HEMOTHERM Model 400CE Serial No. _____

Hospital I.D. No. _____ Check when
completed

- 1. External cabinet and controls in good condition (i.e. no dents or missing parts).
- 2. All warning labels properly affixed.
- 3. Quick disconnect couplings are tight, straight, and not leaking.
- 4. Power cord (i.e. no cuts or exposed wire) and plug (i.e. no bent or missing pins) are in good condition.
- 5. All indicator lights are operative (i.e. heat & cool modes, heaters, pump, power). (Press TEST INDICATORS BUTTON on control panel, Section 1.3)
- 6. Clean water filter (See Section 3.9).
- 7. Clean & disinfect water system (See Section 3.8).
- 8. Leakage current check (all readings should be less than 300 micro amps for 115V units and 500 micro amps for 230V units). (See Section 3.18)
 - OFF normal polarity
 - OFF reverse polarity
 - ON normal polarity (heat)
 - ON reverse polarity (heat)
 - ON normal polarity (cool)
 - ON reverse polarity (cool)
- 9. Perform low limit safeties check. (See Section 3.4)
- 10. Perform high limit safeties check. (See Section 3.5)
- 11. Check Condition of blankets, hoses, couplings (check for leaks). (See Section 3.11)

Signature of Inspector

Date of Inspection

3.21 REQUIRED MONTHLY PREVENTIVE MAINTENANCE CHECKLIST

HEMOTHERM Serial No. _____

Hospital I.D. No. _____

Check when
completed

- 1. Drain and clean reservoirs (See Section 3.7).
- 2. Refill reservoirs with water (See Section 3.7).
- 3. Clean condenser and grille (See Section 3.10).

Signature of Inspector

Date of Inspection

3.22 TROUBLESHOOTING GUIDE

SYMPTOM	POSSIBLE PROBLEM	SOLUTION
1. HEMOTHERM unit will not turn on.	Unplugged	Plug into properly grounded receptacle.
	No electric power at receptacle.	Check O.R. electric power source circuit breakers.
	Power switch/circuit breaker is tripped.	Reset unit's power switch circuit breaker (upper right side panel) by turning OFF and ON. If circuit breaker trips immediately, check for a direct short. If unit operates for 5 minutes or more and again trips, investigate for low line voltage at receptacle.
	Faulty power switch/circuit breaker on right side of unit.	Replace switch.
	Internal wiring continuity.	Troubleshoot for open circuit wiring.
2. No water circulation through blood oxygenator/ heat exchanger.	Pump switch off.	Activate pushbutton switch on control panel. NOTE: LED can be inoperative and switch will still operate.
	Disengaged quick-connect couplings.	Check all couplings to assure <u>full</u> engagement. Partial engagement does not cause couplings to open internally. Collars return to their at-rest position upon full engagement.
	Clogged quick-connect couplings.	Remove couplings and force out any foreign matter with compressed air.
	Clogged water filter.	Clean water filter.
	Vapor lock in unit's liquid piping.	Turn off pump and wait fifteen seconds. Turn the pump back on.

SYMPTOM	POSSIBLE PROBLEM	SOLUTION
2. No water circulation through blood oxygenator/ heat exchanger.	Low reservoir water levels.	Turn the pump off. Fill both reservoirs to bottom of plastic strainer level. Turn the pump back on.
	Cool water reservoir partially or fully iced up	Switch to HEAT mode for ten seconds.
	Tripped circuit breaker.	See Symptom #1.
	Inoperative pump.	Troubleshoot for loss of electrical power to motor, defective motor, or defective pump assembly.
	Inoperative water flow-control solenoid valves.	Troubleshoot for loss of electrical power to affected valve, burned out solenoid coil, or mechanically stuck valve.
3. No circulation through connected patient blanket.	See Symptom #2 possible problems.	See Symptom #2 solutions.
4. Blood oxygenator/ heat exchanger will not cool.	Incorrect operational mode.	Actuate mode selector switch to COOL mode as indicated by LED.
	No water flow to oxygenator.	See Symptom #2.
	Inadequate flow.	See Symptom #2.
		Remove partial obstruction in external liquid circuitry.
		Solenoid valve stuck partially closed. Rap valve body sharply. Clean or replace <u>before next use</u> .
	Worn pump: check output. (13 liters/min at 9 PSI).	
	COOL set point set at too high a temperature.	Check set point by pressing COOL TEMP SET switch.
COOL mode intermittent	Check the COOL reservoir's water temperature sensor for proper resistance values.	
	Troubleshoot or replace the control board.	

SYMPTOM	POSSIBLE PROBLEM	SOLUTION
4. Blood oxygenator/ heat exchanger will not cool.	Refrigeration system inoperative - water in COOL water reservoir not being chilled.	If electrical power is not reaching the compressor, troubleshoot circuitry.
		If electrical power is reaching compressor, troubleshoot compressor.
		Refrigerant charge lost from system. Leak test. Replace filter drier. Then evacuate and recharge. NEW CHARGE – 30 oz. of R-134A. <u>NOTE: DO NOT OVERCHARGE.</u>
5. Blood oxygenator/ heat exchanger cools intermittently	Intermittent or erratic refrigeration system	Check cooling airflow through condenser. Restricted airflow or defective fan motor can cause compressor to thermally overload and periodically shut down.
		Defective compressor or control board or power board.
6. Blood oxygenator/ heat exchanger cool-capacity low.	Water flow partially obstructed.	Check for partial obstruction in external liquid circuit or partially engaged quick disconnect fittings.
	Cool water reservoir partially or fully iced up	Switch to HEAT mode for ten seconds.
	Water flow control solenoid valve is stuck	Clean or replace as soon as possible.
	Partially blocked cooling airflow	Move external equipment from front of cabinet air grille.
6. Blood oxygenator/ heat exchanger cool-capacity low.	Partially blocked cooling airflow	Check for dust and lint accumulation on condenser; remove grille and clean with vacuum. If exceptionally heavy, remove rear panel and blow dust outward with compressed air.

SYMPTOM	POSSIBLE PROBLEM	SOLUTION
		Check condenser cooling fan motor.
	Low refrigerant charge	Refrigerant charge lost from system. Leak test. Replace filter drier. Then evacuate and recharge. NEW CHARGE – 30 oz. of R-134A. <u>NOTE: DO NOT OVERCHARGE.</u>
	Improperly operating thermostatic expansion valve	Prior knowledge of refrigeration principles is required for proper evaluation of this component. Replace and evacuate - recharge if all other refrigeration components have been evaluated.
7. Blood oxygenator/heat exchanger heats very slowly	Heater is inoperative	Check heater: 115 VAC units - one 1500 watt heater 230 VAC units - one 1750 watt heater Check for correct electrical power to heaters.
	Heat set point set below desired temperature	Check set point and reset if necessary.
8. Blood oxygenator/heat exchanger-heats slowly	High heater	Check heater
	Control set point too low	Check set point and reset if necessary.
8. Blood oxygenator/heat exchanger-heats slowly	Low water circulation rate	Check for obstruction in circulation loop.
9. Blanket will not cool	Refer to Symptom #4	Work through POSSIBLE PROBLEMS & SOLUTIONS for Symptom #4 in sequence given.

SYMPTOM	POSSIBLE PROBLEM	SOLUTION
10. Blanket will not cool - Blood oxygenator does cool	Water flow through blanket is restricted	Check: <ul style="list-style-type: none"> • Quick disconnect fittings for full engagement. • Obstruction in interconnecting tubing.
11. Blanket will not heat	Refer to Symptom #7	Check through POSSIBLE PROBLEMS & solutions Symptom #7 in sequence given.
12. Blanket will not heat - Blood oxygenator does heat	Water flow through blanket is restricted	Refer to SOLUTIONS for Symptom #10.
13. Unit will not operate when power switch is "ON"	Power not at power board or control board	Check for power at the power board J1 connection.
		Check all cable connections.
14. LED lights inoperative	LED burned out	Replace control board
15. Water transferring from one reservoir to the other	Foreign matter in solenoid valve(s) - 4 valves total	Remove housing of solenoid valve. Clean, reassemble and replace.
16. High temp limit indicator is illuminated	The heat reservoir temperature has been measured as higher than acceptable safe limits.	If this happens during normal operation, contact GENTHERM customer service for instructions.
17. Low temp limit indicator is illuminated	The cool reservoir temperature has been measured as lower than acceptable safe limits.	If this happens during normal operation, contact GENTHERM customer service for instructions.
18. Low water indicator is illuminated	Water in the respective reservoir is too low.	Add water sufficient to float the water level switch.
	Switch is defective or wiring is disconnected	Replace switch and check wiring.
19. EE02 is indicated	Heat thermistor discrepancy	Replace thermistor
20. EE03 is indicated	Cool thermistor discrepancy	Replace thermistor

SYMPTOM	POSSIBLE PROBLEM	SOLUTION
21. EE05 is indicated	Open or out of range Heat Reservoir Water Temp Sensor.	Check wiring. Replace sensor.
	Open or out of range Heat Reservoir Water Temp Sensor.	Check wiring. Replace sensor.
	A bad heat channel in the control board	Replace control board
	The heat side thermistor may be defective or unplugged	Re-plug and replace if defective
	The thermistor wiring harness could have a loose connection.	Check connection. To determine if the wiring harness has a bad connection or if the thermistor is bad, simply do a continuity (resistance) test on the harness and thermistor. If they appear to be correct, replace the control board
22. EE06 is indicated	Open or out of range Cool Reservoir Water Temp Sensor.	Check wiring. Replace sensor.
	A bad COOL-channel circuit in the control board	Replace control board
	The COOL side thermistor may be defective or unplugged	Re-plug and replace if defective
22. EE06 is indicated	Thermistor wiring harness could have a loose connection.	Check connection. To determine if the wiring harness has a bad connection or if the thermistor is bad, simply do a continuity (resistance) test on the harness and thermistor. If they appear to be correct, replace the control board
23. Power fail indicator is illuminated	Power was interrupted without turning the power switch off for 5 seconds.	Plug unit back in and silence the alarm.

3.23 TROUBLESHOOTING CONTROL OF THE SOLENOIDS

Helpful suggestions to determine which solenoid valve(s) is defective:

MODE OF OPERATION	COOL RESERVOIR	HEAT RESERVOIR	PROBLEM
Heat	Emptying	Filling	A
Heat	Filling	Emptying	B
Cool	Filling	Emptying	C
Cool	Emptying	Filling	D

- A) Cool outlet solenoid
- B) Cool return solenoid

- C) Heat outlet solenoid
- D) Heat return solenoid

SECTION 4. PARTS INFORMATION

4.1 ORDERING INFORMATION FOR REPLACEMENT PARTS

It is strongly recommended that all Hemotherm parts be replaced with original manufacturers' parts. Use of other parts could void the warranty on the unit and possibly damage the unit.

Replacement parts from the factory are shipped F.O.B., Cincinnati, Ohio. Generally, parts orders are shipped within 24 hours after we receive them. International Customers order repair parts directly through their local authorized Hemotherm distributor. Therefore, it is not necessary for you to keep large quantities of parts on hand. However, it may be desirable that your maintenance department keeps a minimum number of recommended parts in stock for emergency use if you have three or more Hemotherm units.

Refer to the Technical Help section of this manual for ordering parts within the USA

To help us serve you better, please have the serial number of your Hemotherm unit available when you call for parts or service. The serial number is located on the side panel of the unit along with the part number. There is no minimum order requirement for replacement parts.

4.2 RETURNING PARTS UNDER WARRANTY

All parts are covered by a one year warranty. Additional warranties may be obtained at the time of purchase. To replace parts during the warranty period*, send the part prepaid to:

GENTHERM MEDICAL, LLC
12011 Mosteller Road
Cincinnati, Ohio 45241
Phone: 1-513-772-8810
Fax: 1-513-772-9119

To qualify for credit, warranty parts should be tagged with the following information:

1. The invoice number under which the unit/part was purchased.
2. Cause of failure.
3. Serial number of unit.
4. Date of installation or purchase.
5. RMA number*

* You must first obtain a RMA number by calling the factory prior to returning an item.

4.3 IMPORTANT INFORMATION FOR SHIPPING RETURNED PARTS

Parts to be returned to the factory should be carefully packaged, especially the control board, and the control panel. Each of these boards should be cushioned in static safe packaging material to prevent damage from Electrostatic Discharge (ESD).

NOTE: Shipping damage will be the responsibility of the shipper. Insure if necessary.

4.4 EQUIPMENT, ACCESSORIES AND PARTS LIST ORDER INFORMATION

Equipment and accessories can be ordered directly from our authorized dealer for your area. For information on your dealer, you can call the Customer Service Department at the factory, at 1-513-772-8810 or 1-800-989-7373.

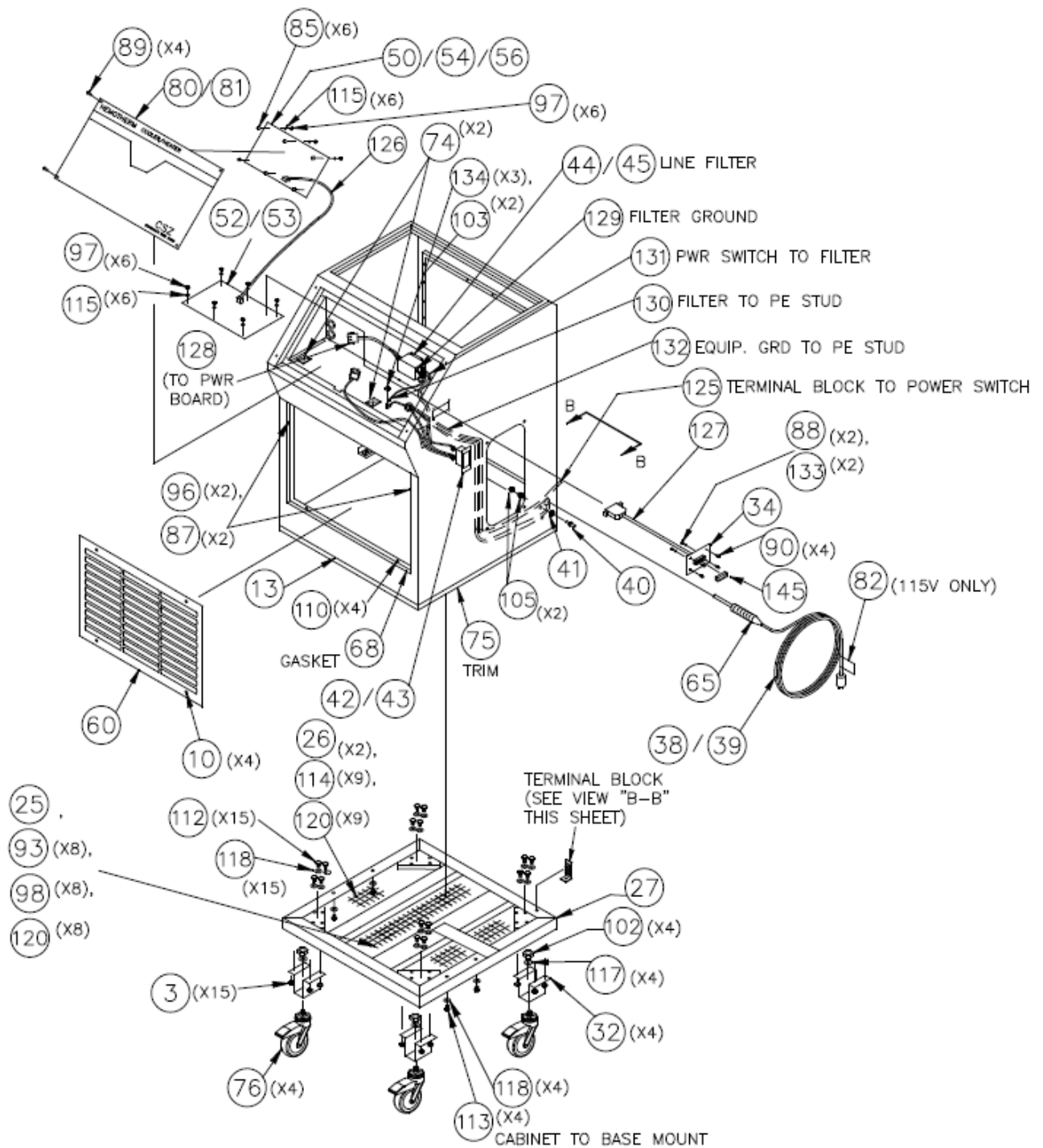

FIGURE 4-1, FRONT ASSEMBLIES AND PARTS

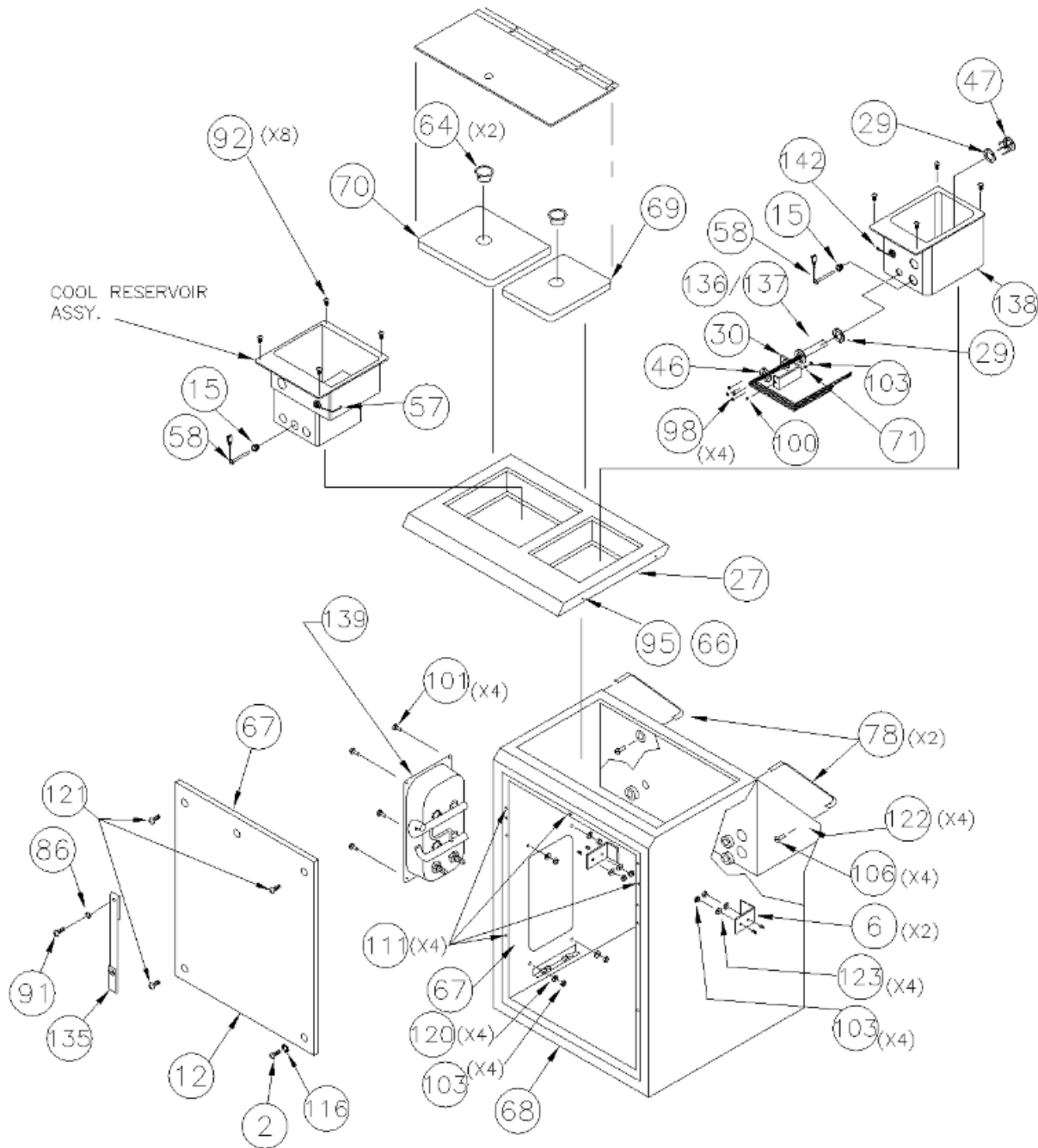

FIGURE 4-2, BACK ASSEMBLIES AND PARTS

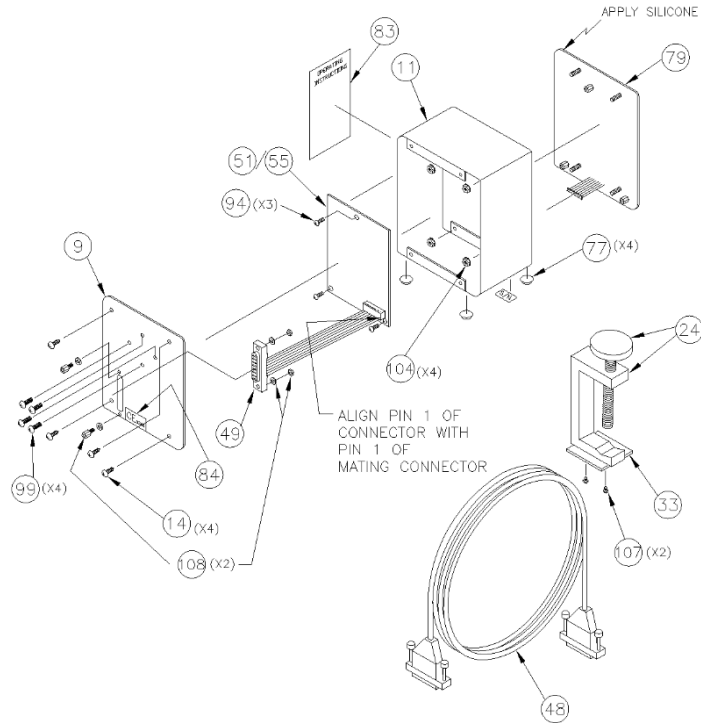

FIGURE 4-5, 115V HEMOTHERM REMOTE

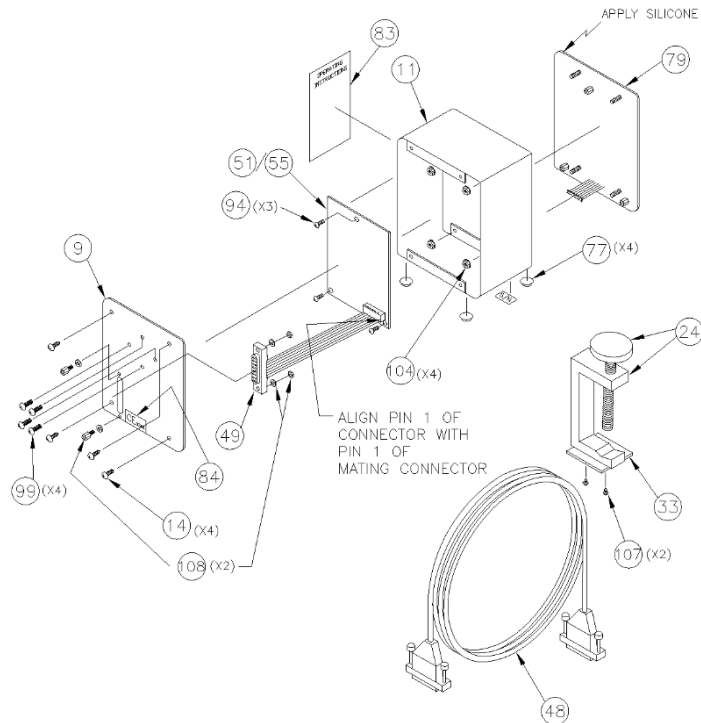

FIGURE 4-6 230V HEMOTHERM REMOTE

4.5 PARTS LIST FOR HEMOTHERM (FIGURE 4-1 THROUGH 4-6)

BUBBLE NO.	QTY/UNIT	PART DESCRIPTION
1	1	CONDENSER,SPECIAL, CC 75, HEMO
2	1	HEX SCREW
3	41	KEPS NUT
4	1	COMPRESSOR, 115VAC, HEMO
5	1	COMPRESSOR, 230V, R134A, HEMO CE
6	2	CONDENSER ANGLE BRACKET
7	2	CONDENSER SIDE MOUNT
8	2	ASSY., CONDENSER BASE MOUNT
9	1	REAR COVER, HEMO CE REMOTE
10	4	EXP.,#8X3/4 PHILPANTIS TYPE AB WH HE Z
11	1	CABINET,REMOTE, (GRAY), HEMO
12	1	PANEL, REAR, CABINET WHITE, HEMO
13	1	CABINET, HEMOTHERM, 400CE
14	4	EXP.,SCREW,S/M #8 x 1/2, PWDR COAT
15	2	BUSHING,REDUCING,BRA,1/4X1/8
16	1	FLARED UNION, BRASS, 1/4F X 1/4F X 1IN
17	2	UNION,FLARE,BRASS 1/2 X 1/2
18	2	UNION,REDUCING,BRASS 1/2 X 1/4
19	1	TUBE, COPPER #2, HEMO CE
20	1	TUBE, COPPER #2, HEMO CE
21	2	TUBE, COPPER #3, HEMO CE
22	2	ASSY, REFRIGERATION ISOLATION HOSE
23	1	TUBE, COPPER #4, HEMO
24	1	CLAMP, MOUNTING POLE
25	1	BASE, CENTER GUARD, HEMO
26	2	GUARD, BASE, SIDE, HEMO
27	1	FRAME, BASE, STAINLESS, HEMO CE
28	1	HEMO CAPACTIOR BASE BRACKET
29	2	HEATER GASKET, RUBBER
30	1	HEATER MTG BRACKET, HEMO CE
31	1	MOTOR BRACKET, FAN, HEMO CE
32	4	BRACKET, CASTER, HEMO CE
33	1	CLAMP, MOUNTING, PLATE
34	1	REMOTE CABLE MOUNTING PLATE, HEMO CE
35	1	CLIP, CABLE (19/64-13/32)2
36	2	CONNECTOR, 3/8" DC 2-SC SMC
37	2	EXP., CONN, SOCKET,14-20, UMNL II, PIECE
38	1	CORD ASSEMBLY, 12/3 SJT, BLACK,15', HEMO
39	1	CORD, SET, 3 X 1.50X 15', BII/HEMO
40	1	EXP., LUG, GROUND, EUROPEAN
41	1	EXP., WASHER, GROUND LUG, GREEN/YEL
42	1	SWITCH, CIRCUIT BREAKER,15N230, HEMO
43	1	SWITCH, CIRCUIT BREAKER,115/20, HEMO
44	1	FILTER, LINE 15AMP MEDICAL GRADE, HE

BUBBLE NO.	QTY/UNIT	PART DESCRIPTION
45	1	FILTER, LINE, 20AMP MEDICAL GRADE
46	1	HEATER WASHER, S.S.
47	1	HEATER ATTACHMENT RING, S.S.
48	1	WIRE ASSY, 25FT CABLE, HEMO CE REMOTE
49	1	WIRE ASSY,RIBBON CABLE,HEMO 400CE REMOTE
50	1	BOARD, CPU, 230V HEMO CE
51	1	BOARD, CONTROL, HEMO CE REMOTE
52	1	BOARD, POWER SUPPLY, 115VAC, HEMO CE
53	1	BOARD, POWER SUPPLY, 230VAC, HEMO CE
54	1	BOARD, CONTROL, 230V, HEMO CE
55	1	OBS, BOARD, CONTROL, HEMO CE REMOTE
56	1	BOARD, CPU, 115V HEMO CE
57	1	SWITCH, FLOAT, POLYPRO 100, HEMO/ECMO
58	2	THERMISTOR, BETATHERM, PLASTIC
59	1	FAN BLADE, CONDENSER
60	1	GRILLE, 18"X 12", POWDER COATED, HEMO
61	1	PUMP, 100/115V (TE), HEMO
62	1	PUMP, WATER, 230V 5C, HEMO
63	11	MOUNT,VIBRO INSULATOR, 1 INCH, HEMO
64	2	STRAINER, PLASTIC,SINK,1-1/2
65	1	STRAIN RELIEF, PG13.5, HEMO
66	1	EXP., CAP,SNAP,WITH WASHER, 8 WHITE
67	2	FOAM, DEADENER,SOUND, 1/2, BII/HEMO/NOT
68	2	EXP., GASKET, SPONGE, BLACK, 1/8X 1/2
69	1	COVER, HEATING, RESERVOIR,WHITE, HEMO
70	1	COVER, COOLING, RESERVOIR, WHITE, HEMO
71	1	EXP., WASHER, M6, SS, FLAT
72	1	PUMP SHROUD, HEMO CE
73	1	FAN SHROUD HEMOTHERM CE, SHEET MET
74	2	EXP., QTIE, CABLE, MGT ADB, BACK, 3/4
75	1	EXP., TRIM, FLEXIBLE, BLACK, HEMO
76	4	CASTER, SWIVEL, 4 IN, LOCKING
77	4	EXP., BUTTON BUMPER, BLACK, RUBBER
78	2	HANDLE, 8" WI BLK EPOXY FINISH, HEMO
79	1	CONTROL PANEL, HEMO CE REMOTE
80	1	CONTROL PANEL, EUROPE, HEMO CE
81	1	CONTROL PANEL,DOMESTIC, HEMO CE
82	1 (115V ONLY)	LABEL, GROUND INTERITY,HEMOBII/NOT/MTII
83	1	EXP., LABEL, REMOTE CONTROL,INST, HEMO
84	1	EXP., LABEL, CE MARK
85	6	EXP,SPACER, PLASTIC, #8 X 3/16
86	1	EXP., DOT #10370 SNAP STUD
87	2	EXP., STANDOFF M/F M4 PLASTIC
88	2	STANDOFF, M/F 4-40 X 3/16, BRASS,HEMO
89	4	EXP.,#6 X 3/4 PHIL FLAT TIS "AB" ZINC

BUBBLE NO.	QTY/UNIT	PART DESCRIPTION
90	4	EXP.,#6 X 3/8 PHIL PAN T/S "AB" ZINC
91	1	EXP., 8 X 1 OVAL PHIL SMS 2/#6 HD. CHRМ
92	8	EXP., #8X1/2 PHIL PAN TIS TYPE "A"300 S/S
93	8	EXP., SCREW, SLOT/WH MACH.8-32 X 1/2"ZIN
94	3	EXP.,6-32 X 1/4 PHIL PAN M/S BRASS
95	1	EXP., SCREW, SNAP, 8 X 1/2 PRO-DEC
96	2	OBS, EXP., NUT, FLANGE, M4, PLASTIC
97	12	EXP., NUT, 6-32 MACH, BRASS
98	12	LOCKNUT
99	4	EXP.,SCREW,MACH,8/32X1/2,B/OXIDE
100	1	EXP., SCREW, 8-32 X 1/2 IN TRUSS HEAD
101	4	EXP. SCREW, TRUSS HEAD, 8-32 X 3/4 IN
102	4	EXP., NUT, HEX, 1/2-13, ZINC
103	14	KEPS NUT
104	4	EXP., NUT, KEPS, 6-32
105	2	EXP., NUT, KEPS, PLATED M6
106	4	HEX SCREW
107	2	EXP.,8X32 X 1/4 PHFLHD SCREW
108	2	HEX SCREW JACK ASSY., 1/2 IN LONG
109	4	NUT, HEX, SST, NYLON INSERT, 10-32 THREADED
110	4	EXP., SPEED NUT, TINNEMAN #C8113-8-4
111	4	EXP., TINNEMAN"U" CLIP #8 ZINC
112	19	EXP., 1/4-20 X1/2 HHCS GR2 ZINC
113	4	EXP. SCREW, TRUSS HEAD, 8-32 X 3/4 IN
114	13	EXP., RIVET, OPEN END, ALU BODV, 5/32
115	12	EXP., #6 INTERNAL TOOTH L/W 410SS
116	1	EXP., #8 INTERNAL TOOTH L/W 410SS
117	4	LOCKNUT
118	30	EXP., WASHER, FLAT, 1/4 SAE, ZINC
119	12	EXP., WASHER, FENDER 1" OD ZINC
120	25	EXP., #10 F/W .200X1/2X.040 BRASS
121	3	EXP.,#8 X 1 PHIL PANTIS "AB" ZINC
122	4	EXP., WASHER, SHAKEPROOF #10
123	4	EXP., WASHER, CUP, #8, S/S
124	4	EXP, SCREW, 1/4-20X3/4 SHCS
125	1	WIRE ASSY, TERM BLOCK TO PWR SW, HEMO CE
126	1	WIRE ASSY, PWR BD TO CPU BD, HEMO CE
127	1	ASSY, REMOTE CABLE, CPU TO CABINET, HEMO CE
128	1	WIRE ASSY, FILTER TO PWR BD J1, HEMO CE
129	1	WIRE ASSY., GND, FLTR TO FLT STUD, HEMO CE
130	1	WIRE ASSY, FILTER GND STUD TO PE STUD
131	1	WIRE ASSY, PWR SW TO FILTER, HEMO CE
132	1	WIRE ASSY, EQ GND TO PE, HEMO CE
133	2	EXP., NUT, KEPS, 4-40 SS, MT
134	3	EXP., HEX NUT, 8-32

BUBBLE NO.	QTY/UNIT	PART DESCRIPTION
135	1	STRAP, NYLON, ASSEMBLY., BII/HEMO/N.O.T/BIII
136	1	ASSY., 115V HEATER, SERVICE
137	1	ASSY., 230V HEATER, SERVICE
138	1	ASSY, HTR RESERVOIR, HEMO 400CE, SERVICE
139	1	ASSY., PAN MANIFOLD, HEMO 400CE, SERVICE
140	1	WIRE ASSY, FAN MOTOR WITH TERMS, 115V
141	1	WIRE ASSY, FAN MOTOR WITH TERMS, 230V
142	1	FLOAT SWITCH ASSY.,REPLACEMENT
143	1	HOSE, DRAIN, ASSY., HEMO
144	1	INDICATOR, ASSY, WATER FLOW
145	1	REMOTE PORT COVER

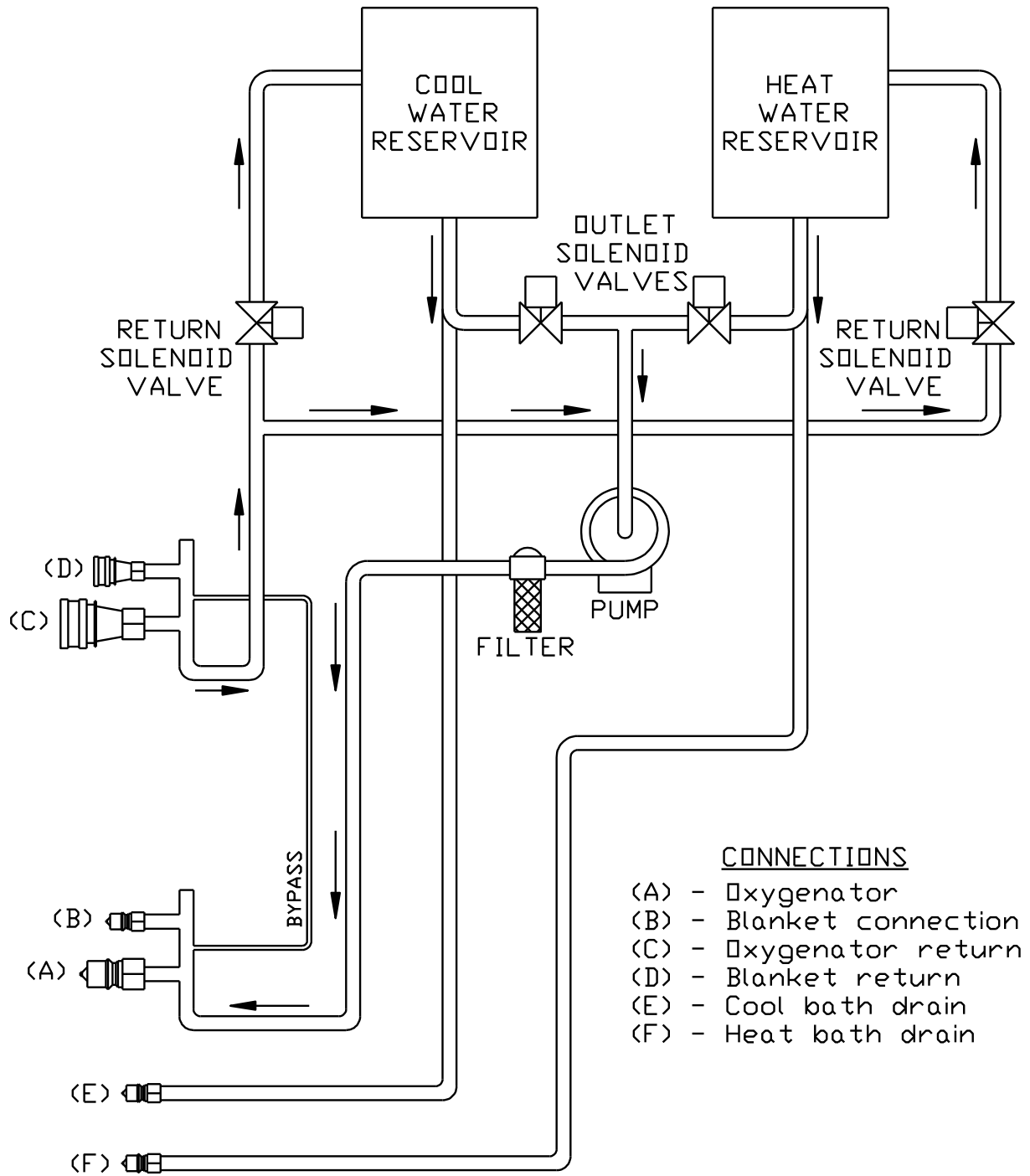

FIGURE 4-9, WATER CIRCULATION DIAGRAM

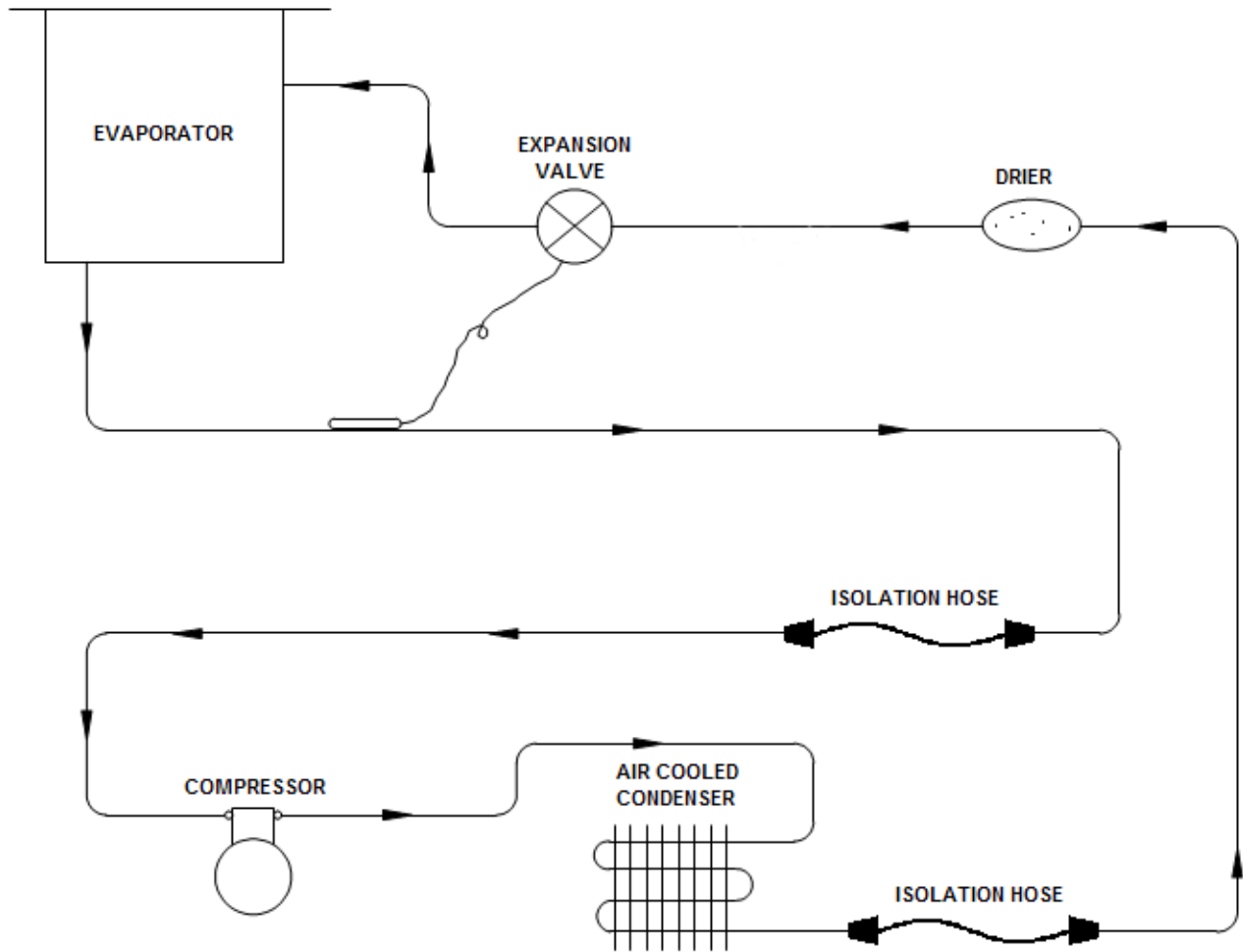

FIGURE 4-10, REFRIGERATION FLOW DIAGRAM



GENTHERM



Gentherm Medical, LLC
12011 Mosteller Road
Cincinnati, OH 45241
www.gentherm.com

Telephone: (513) 772-8810



Fax: (513) 772-9119